



EUROPEAN CENTRAL BANK

EUROSYSTEM

# Treading softly: How central banks are addressing current global challenges

ECB Legal Conference 2023

December 2023





EUROPEAN CENTRAL BANK  
EUROSYSTEM

# Treading softly: How central banks are addressing current global challenges

ECB Legal Conference 2023

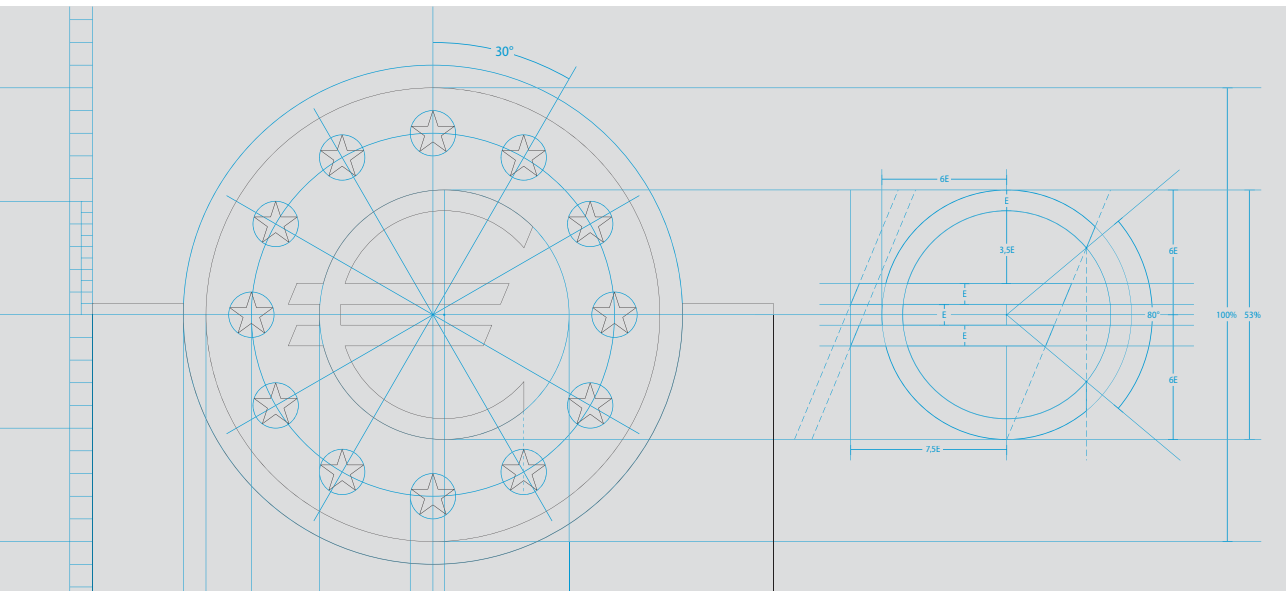



# Contents

<b>Introduction</b>	<b>5</b>
<i>Chiara Zilioli</i>	
<b>Part I</b>	
<b>Climate- and environment-related litigation</b>	<b>11</b>
“Come hell or high water”: addressing the risks of climate and environment-related litigation for the banking sector	12
<i>Frank Elderson</i>	
<b>Part II</b>	
<b>Independence, accountability and proportionality in the context of the ESCB’s secondary mandate</b>	<b>23</b>
Independence, accountability and proportionality in the context of the ESCB’s secondary mandate: an introduction	24
<i>Philip R. Lane</i>	
Proportionality in German constitutional law	28
<i>Alexander Thiele</i>	
The constitutional assessment of the ECB’s objectives and tasks outside monetary policy	39
<i>Klaus Tuori</i>	
<b>Part III</b>	
<b>Incorporation of environmental considerations in the supervision of prudential risks</b>	<b>55</b>
What is special about climate-related and environmental risks?	56
<i>Isabel Schnabel</i>	
Environmental protection and prudential risk supervision: legal reflections	60
<i>Suzanne Kingston</i>	
Incorporating climate and environmental considerations in prudential regulation and supervision of financial risks: an open and iterative approach	72
<i>Juliana B. Bolzani</i>	
The incorporation of environmental considerations in the regulation and supervision of prudential risks	96
<i>Veerle Colaert</i>	

<b>Part IV</b>	
<b>Central bank immunities and international sanctions</b>	<b>111</b>
Central bank immunities and international sanctions: an introduction <i>Chiara Zilioli</i>	112
Sanctions, Asset Freezes, Confiscations and Immunity: an Overview <i>Ingrid (Wuerth) Brunk</i>	118
Economic sanctions and the law of central bank immunity in the United States <i>Richard Ostrander</i>	124
Use of the immobilized Russian Central Bank assets to rebuild Ukraine: between political will and legal hurdles <i>Iryna Bogdanova</i>	134
<b>Part V</b>	
<b>Monetary Sovereignty: meaning and implications</b>	<b>147</b>
Monetary sovereignty: the euro and strategic internationalization <i>Jens van 't Klooster</i>	148
CBDC and monetary sovereignty <i>Corinne Zellweger-Gutknecht</i>	165
<b>Part VI</b>	
<b>Filling the gaps: central banks, competent authorities and legislative frameworks</b>	<b>185</b>
Filling the gaps: central banks, competent authorities and legislative frameworks: an introduction <i>Edouard Fernandez-Bollo</i>	186
ECB opinions on national legislative proposals: practice to date and outlook <i>Diane Fromage</i>	193
The ECB advisory role: opinions as soft law in a shared normative space <i>David Ramos Muñoz</i>	207
To consult, or not consult: the question on the legal consequences <i>Miguel Sampol Pucurull</i>	225

<b>Part VII</b>	<b>251</b>
<b>Preliminary rulings: the past, the present and the future</b>	
Preliminary rulings - the past, the present and the future: an introduction <i>Frank Elderson</i>	<b>252</b>
The past, present and future of the preliminary reference procedure <i>Sacha Garben</i>	260
Developments of the preliminary reference procedure in a historical perspective <i>Vittorio Di Bucci</i>	276
Effective judicial review in the banking union <i>Lucia Serena Rossi</i>	286
<b>Part VIII</b>	<b>301</b>
<b>Protection of Fundamental Rights in the European Multilevel System</b>	
<b>Protection of Fundamental Rights in the European Multilevel System</b> <i>Prof. Dr. Stephan Harbarth</i>	302
<b>Concluding Synopsis</b> Chiara Zilioli	<b>313</b>
<b>Biographies</b>	<b>319</b>



# Introduction

Chiara Zilioli\*

On 18 June 1940, Winston Churchill spoke at the House of Commons<sup>1</sup> to comment on the military operations which had started on the European continent, and which would later be defined as World War II. At the current juncture, as we are becoming acquainted with the idea that the surface of our continent is again scarred by trenches while both soldiers and innocent civilians are victims of an unjustified aggression of an independent State, Churchill's reference to the "the darkest hour" echoes among us. According to an English proverb, however, the darkest hour is just before the dawn.

Like sailors in the middle of the night needed the stars to find their way across the sea, in the darkest hour we need a compass to find our way. For EU institutions and citizens there is no better compass than the values which are enshrined in our Treaties, and which are the foundations of the political project that the representatives of the States which came out of the war decided to set up together, to avoid that war would happen again in Europe.

Article 3(5) of the Treaty on European Union (TEU) seems particularly salient in this context: "In its relations with the wider world, the Union shall uphold and promote its values and interests and contribute to the protection of its citizens. It shall contribute to peace, security, the sustainable development of the Earth, solidarity and mutual respect among peoples, free and fair trade, eradication of poverty and the protection of human rights, in particular the rights of the child, as well as to the strict observance and the development of international law, including respect for the principles of the United Nations Charter."

This ambitious programme informed our actions when we planned the ECB Legal Conference 2023, which would ultimately evolve into the book you are reading. To contribute to peace, especially in our vicinity; to contribute to the sustainable development of the Earth; the strict observance and the development of international law (including respect for the principles of the United Nations Charter): these three challenges would probably feature among the top three which the EU and the world as a whole are facing at the time of writing. In addition to these issues, we thought that other challenges deserve consideration, given their importance for an audience of legal professionals.

The goal for our annual conference has always been comprehensive and ambitious. We strive to capture developments in various areas of law – whether in monetary policy, financial regulation, human rights or administrative law. We aim to be a melting pot of ideas where policy meets practice, where theory confronts reality, and where questions are not just raised, but are also rigorously examined and answered.

---

\* Director General Legal Services, European Central Bank, Professor at the Law Faculty of the Goethe University in Frankfurt am Main.

<sup>1</sup> "Their finest hour", speech, 18 June 1940.



We believe that such a multidisciplinary focus is essential because the law does not operate in a vacuum. It is influenced by, and exerts influence upon, a multitude of sectors, norms and even societal expectations. In a world that is ever more complex, interconnected and laden with unforeseen challenges, it is not sufficient to be masters of our own specialised domains. We must be cognisant of how different areas of law intersect, diverge and inform one another. We must also be ready to adapt and evolve as the legal landscape undergoes its inevitable shifts.

A critical aspect of this continuous evolution is the judiciary. I am particularly thrilled to see so many judges among the authors of the various chapters of this book. Judges play an indispensable role in shaping the legal framework, setting precedents and providing interpretations that can change the course of law for generations. Their contributions serve as a reminder of the vitality and dynamism inherent in law. While legislatures may lay down the law, it is the judges who often set its course through their wisdom, judgments and interpretive insights. The symbiotic relationship between representatives of the judiciary and of academia yields discussions that are not just theoretically robust, but also invaluable in practice.

In this introduction, I would like to focus on the main themes underlying this book, which were carefully curated to reflect the *Zeitgeist* of contemporary legal challenges and opportunities, along with a forward-looking perspective on the emerging issues that are likely to shape our understanding and practice of law in the coming years.

## 1 The newly discovered boundaries of the mandate of central banks in a dynamic global context

The role and visibility of central banks has evolved significantly in recent times, expanding beyond traditional monetary policy and financial stability. The onset of global challenges, including financial crises, technological advancements and geopolitical shifts, has pushed central banks to explore the boundaries of their competences and test new tools. This evolution reflects the complex interplay of the economic, political and societal factors that shape our societies.

The rapidly expanding academic and policy debate on central banks' role in addressing climate-related financial risks signifies a paradigm shift. Notwithstanding the primary objective of price stability, the Treaty on the Functioning of the European Union tasks the Eurosystem with supporting the general economic policies in the EU with a view to contributing to the achievement of the EU's objectives as laid down in Article 3 (TEU). Central banks and financial regulators are thus now considering, as the Treaty requires, the incorporation of climate change impacts and considerations into financial stability assessments and regulatory frameworks.<sup>2</sup>

Central banks are required to integrate a wider range of economic and policy considerations into their tasks and activities. This requires a balancing act between traditional considerations and new perspectives. The move towards a more open

---

<sup>2</sup> See M. Ioannidis, S. J. Hlásková Murphy, C. Zilioli, "The mandate of the ECB: Legal considerations in the ECB's monetary policy strategy review", *Occasional Paper Series*, No 276, ECB, September 2021.

interpretation of the mandate of central banks reflects their growing importance in addressing challenges that are economic in their consequences but have their origin in broader societal challenges. This more open role, however, necessitates a continuous re-examination of strategies and tools to meet the ever-changing demands of a dynamic global context, while remaining faithful to the mandate given by the Treaty.

The way in which central banks can play their role in addressing current global challenges raises fundamental questions about the secondary mandate of the European System of Central Banks (ESCB). While the primary mandate is well understood and well defined, the secondary objective serves as a nuanced but essential layer supporting EU policy decisions and legislative considerations. The question remains whether such supporting measures adopted by the ECB within the context of its secondary mandate imply different standards of independence, accountability and proportionality. This book attempts to give a modest contribution to unpacking the intricacies and implications of the topic, but it also represents a call to academics who are willing to engage with this challenge and look into these questions more in detail.

## 2 Climate change: a new frontier for central bank policy

The contribution that central banks can provide to the fight against climate change is particularly worth noting in this context. Central banks are increasingly tasked with considering environmental risks as part of their mandate. Financial regulators are similarly adjusting their frameworks to incorporate climate risks, recognising that these can lead to systemic financial shocks. The challenges in this new role include the development of expertise in environmental risk assessment and integrating these considerations into existing financial models, while the opportunities lie in fostering a more sustainable and resilient financial system.

The intersection of climate change and financial policy represents a critical juncture in global economic governance. The growing awareness of the impact of climate change has spurred a paradigm shift, placing environmental sustainability at the forefront of policy debates. While environmental factors have been for long time largely omitted from the central banks' purview, this approach is being challenged by the growing recognition that climate change poses significant risks to financial stability, and that climate litigation poses risks to central banks and supervisors and to banks. Recent developments, such as the increased frequency of climate-related disasters and shifts in investment patterns towards more sustainable practices, have underscored the need for a more holistic approach to financial regulation. The rationale for this shift is rooted in the understanding that environmental health is intrinsically linked to economic stability.

The integration of climate considerations into financial regulation and into monetary policy has profound theoretical and practical implications. Theoretically, it represents a shift towards a more integrated approach to economic governance, where environmental and financial stability are seen as interdependent. Practically,

implementing these changes poses significant challenges, including the need for international coordination and the potential for short-term economic disruptions. Although the approach to integrating climate risks into central banking varies globally, examples from various jurisdictions show that proactive policy changes, such as green bonds and carbon pricing, can effectively contribute to align financial practices with climate goals. As the adverse impacts of climate change continue to intensify, it is therefore essential for monetary and financial authorities around the world, including the ECB – both in its capacity as a central bank and as a banking supervisor –, to address climate and environment-related risks.

### 3 Interplay between national and supranational legal frameworks

Although central banks are seen by some – and increasingly so – as a kind of *deus ex machina* with the power to solve any issue which they are faced with, their main feature is that they are creatures of the law, which have to act in conformity with the law, and respond for the use they make of the powers they have been attributed. The accountability to the legislator and to the judiciary is particularly important in this context; and this is even more the case in a multi-level environment like the European Union.

It is worth stressing once more the pivotal role that the Court of Justice of the European Union (CJEU) plays in interpreting EU law and ensuring its uniform application across Member States. The intricate relationship between the CJEU and national courts underscores a fundamental tension within the EU, the balance between national sovereignty and supranational authority. The CJEU's role in interpreting EU law ensures its uniform application across Member States, often leading to a redefinition of national sovereignty in line with supranational directives.

From a different perspective, looking at the international relations, considerations of international law influence the way we understand and act upon the concept of monetary sovereignty, as well as the stances we take on matters such as international sanctions, where the instinctive wish to support certain solutions needs to be carefully weighed against the need to preserve a rule-based international order as an essential pre-requisite to the peaceful coexistence of people on this planet.

## Conclusion

As we navigate through these tumultuous times, reminiscent of Churchill's "darkest hour," our collective resilience and determination are more crucial than ever. The European Union, guided by the steadfast compass of its fundamental values, stands at the forefront of addressing contemporary challenges. These values not only provide direction but also infuse our actions with purpose, as evidenced by the diverse themes explored in this volume.

As a consequence of the changed societal environment, monetary policy and financial regulation are going through an era of transformation. In this context, the mandate of central banks, particularly the ECB, needs to be fully exploited and reinterpreted: these institutions, while remaining primarily concerned with price stability, now grapple also with a broader array of societal challenges, including climate change and its financial implications. This coming into light of the secondary responsibilities of the central bank underlines the necessity for the latter, within its mandate, to adapt and innovate, including in the traditional roles with emerging responsibilities in a dynamic global landscape.

The role of central banks in contributing to combat climate change marks a significant shift in global economic governance. Recognising the profound impact of environmental risks on financial stability, these institutions are now integral players in supporting the move towards a sustainable and resilient financial system. This new frontier requires efforts to include environmental considerations into economic policies, aligning financial practices with long-term sustainability goals.

Furthermore, the intricate relationship between national and supranational legal frameworks, particularly in the context of the European Union, underscores the delicate balance between sovereignty and collective governance. The pivotal role of the CJEU in interpreting EU law exemplifies the dynamic tension inherent in this balance, redefining national sovereignty within a cohesive European framework.

In conclusion, this volume, through its exploration of these topical and strategically important themes, underscores the interconnectedness of law, policy and societal values in shaping our collective future. As we face the myriad challenges of our era, the insights and discussions presented herein serve not only as a reflection of our current legal and political landscape but also as a beacon, guiding us towards a more integrated, sustainable and just future. In this journey, the role of law as both a reactive and proactive force is paramount, moulding our responses and shaping the path forward.

Our wish is that this book will serve as a valuable resource for readers in the ongoing reflection on these significant matters.



# Part I

## Climate- and environment- related litigation

# “Come hell or high water”: addressing the risks of climate and environment-related litigation for the banking sector

Frank Elderson\*

## 1 Introduction

It is a pleasure to welcome you to Frankfurt and to the ECB’s Legal Conference. Arriving this morning and seeing such a large gathering of lawyers – attentive, curious and pleased to see old friends again – I am reminded of the “**back-to-school**” feeling after the summer.

I hope my intervention today can channel that energy towards the major challenge of our time: the climate and environmental crises. After all, summers now are very different from those we may remember from our youth.

Some Europeans faced hell this summer. Record-breaking heatwaves scorched the Mediterranean. Forest fires claimed lives and destroyed homes in Greece. And residents in northern Italy and central Europe were hit by extreme flooding. Meanwhile, similar disasters have been unfolding worldwide. Canada is experiencing its worst wildfire season on record. Wildfires in Hawaii killed more than 100 people. And recent flooding in China is thought to have displaced over one million people. Without human-induced climate change, these events would have been virtually impossible.<sup>3</sup> Back in 2015 Mark Carney spoke about the **tragedy of the horizon**.<sup>4</sup> Eight years on, we have arrived at that horizon. The tragedy is upon us and it has started to unfold.

Today is therefore an appropriate moment to recall one of the key channels through which Mark Carney anticipated that the financial sector – and financial stability – would be affected by the climate crisis: **liability risk**. And by that I am referring to climate and environment-related litigation.

A recent UN report observed that climate-related litigation is central to efforts to compel both governments and corporate actors to pursue more ambitious climate change mitigation and adaptation goals.<sup>5</sup> While governments were the most common

---

\* Transcript of keynote speech given during ECB Legal Conference 2023. Member of the Executive Board of the ECB and Vice-Chair of the Supervisory Board of the ECB.

<sup>3</sup> World Weather Attribution (2023), “Extreme heat in North America, Europe and China in July 2023 made much more likely by climate change”, 25 July.

<sup>4</sup> This phrase describes the fact that the catastrophic impacts of climate change will be felt beyond the traditional horizons of most actors, who thus have limited incentives to mitigate it. See Carney, M. (2015), “Breaking the tragedy of the horizon – climate change and financial stability”, speech at Lloyd’s of London, London, 29 September.

<sup>5</sup> UN Environment Programme (2023), *Global Climate Litigation Report: 2023 Status Review*, 27 July.

targets of such litigation in the past, cases are now also increasingly being filed against corporates.

For supervisors and banks alike, this is becoming a major source of risk that needs to be properly anticipated and addressed. And it is particularly important at a time when non-financial but also financial companies, including banks, are becoming the direct targets of such litigation. This brings me to the key message of my remarks today: litigants are coming after the banks, “**come hell or high water**”<sup>6</sup>. And the banks need to be prepared.

The ECB’s Legal Conference is the perfect forum to discuss this topic for two reasons. First, it is about the role of lawyers – and of courts – in the fight against the climate and environmental crises. Second, as banking supervisor, the ECB finds that banks still need to make significant progress in increasing their awareness of climate and environment-related litigation risk, and they need to be better prepared to address this risk.<sup>7</sup>

## 2 Climate-related litigation and its impact on the financial sector – new reports by the Network for Greening the Financial System

The rise in climate-related litigation should not come as a surprise. The Network for Greening the Financial System<sup>8</sup> (NGFS) already identified it as an emerging source of risk for the financial sector back in 2021.<sup>9</sup> And in fact, I also spoke about it at the ECB Legal Conference two years ago.<sup>10</sup>

Since then, the number of cases has exploded. Globally, some 560 new cases have been filed since 2021.

Against this backdrop, last Friday the NGFS published two new reports on climate-related litigation. The first provides an update on this trend and considers how it may affect banks and the financial sector.<sup>11</sup> The second looks at how this risk needs to be addressed from a supervisor’s perspective.<sup>12</sup>

---

<sup>6</sup> This phrase was coined in the 19th century to describe the gritty determination of the pioneers making their way across the United States to carve out a better future for themselves, undeterred by obstacles and dangers. The phrase can equally be used to describe the determination of climate activists to use the justice system to fight the climate crisis – and the hell and high water that crisis is already generating.

<sup>7</sup> ECB Banking Supervision (2022), *Walking the talk: Banks gearing up to manage risks from climate change and environmental degradation*, November; and ECB Banking Supervision (2022), *Good practices for climate-related and environmental risk management*, November.

<sup>8</sup> Since its foundation in 2017, the NGFS has grown from eight to 127 members, encompassing central banks and supervisors from five continents. The purpose of the NGFS is to help strengthen the global response that is required to meet the goals of the Paris Agreement and to enhance the role the financial system plays in managing risks and mobilising capital for green and low-carbon investment in the broader context of environmentally sustainable development.

<sup>9</sup> NGFS (2021), *Climate-related litigation: Raising awareness about a growing source of risk*, November.

<sup>10</sup> Elderson, F. (2021), “When you need change to preserve continuity: climate emergency and the role of law”, speech at the ECB Legal Conference 2021, Frankfurt am Main, 25 November.

<sup>11</sup> NGFS (2023), *Report on climate-related litigation*, 1 September.

<sup>12</sup> NGFS (2023), *Report on micro-prudential supervision of climate-related litigation risks*, 1 September.



### 3 Expanding precedents – from States to companies

As the NGFS report shows, litigation first targeted **States**.

One of the first landmark cases was the Urgenda case in the Netherlands in 2019. The Dutch Supreme Court ordered the Dutch Government to take more ambitious action to reduce its greenhouse gas emissions. The success in the Urgenda case has since been replicated in cases before the highest courts in France, Ireland and Germany – though naturally with different legal arguments, tailored to each legal system. These cases against States are often referred to as “systemic” climate cases<sup>13</sup> and have been launched in no fewer than 34 jurisdictions worldwide.<sup>14</sup> The cases bring about and accelerate changes in policy, while also providing clarity on duties and responsibilities. But they are also an increasingly important source of transition risk for the economy and the financial sector, as they can lead to rapid court-mandated pivots in public policy aimed at reducing greenhouse gas emissions across the economy.

Moreover, we have recently seen a remarkable increase in **cases against corporates**. Litigation has been launched against a wide range of companies across various sectors of the economy. Fossil fuel and energy companies have been obvious targets, but also car manufacturers, airlines, food companies and producers of concrete and plastics. A wide variety of legal arguments are being used as the basis for such claims.<sup>15</sup> We are seeing claims for **damages under tort law**, for breaches of **corporate due diligence laws** and for **greenwashing**<sup>16</sup>. And we are also increasingly seeing non-governmental organisations (NGOs) buying shares in companies, so that they can subsequently attempt to make the directors personally liable for **breaching their fiduciary duties** to adapt the company to the climate transition.

A telling aspect of this trend is the strategic approach that these litigants take: their lawyers build their cases on the arguments and experiences of peers in other jurisdictions, cooperating through cross-border networks while also developing jurisdiction-specific arguments and strategies. A line of argument that has been successful in one jurisdiction does not necessarily lead to a similarly successful outcome in another, but some arguments have been replicated in multiple countries.

As an example, consider a legal strategy that has proven to be particularly potent in recent years. Once a case against a State has established that the fundamental rights of citizens have been violated, we have seen subsequent cases use this as a basis to argue that private companies also have **a duty of care under civil law to protect citizens’ fundamental rights**. In practical terms, this means a duty to have a realistic

<sup>13</sup> Systemic climate litigation refers to climate-related lawsuits that are lodged against governments and that challenge the overall effort of a State or its bodies to mitigate or adapt to climate change.

<sup>14</sup> Setzer, J. and Higham, C. (2023), [Global trends in climate change litigation: 2023 snapshot](#), Grantham Research Institute on Climate Change and the Environment, 29 June.

<sup>15</sup> See footnote 12.

<sup>16</sup> While there is no common international definition of greenwashing, the three European Supervisory Authorities (European Banking Authority, European Securities and Markets Authority and European Insurance and Occupational Pensions Authority) recently defined greenwashing as “a practice where sustainability-related statements, declarations, actions, or communications do not clearly and fairly reflect the underlying sustainability profile of an entity, a financial product, or financial services. This practice may be misleading to consumers, investors, or other market participants.” See European Banking Authority (2023), “ESAs present common understanding of greenwashing and warn on related risks”, 1 June.

and credible plan to reduce their greenhouse gas emissions. In the Netherlands, this was a winning argument in the first-instance decision in the case against Shell<sup>17</sup>. The Court ordered Shell to reduce its emissions by 45% by 2030, compared with 2019 levels, across all activities and all jurisdictions in which it operates.<sup>18</sup> A similar line of reasoning is being used in a case against the Italian company Eni and its shareholders.<sup>19</sup>

These cases are particularly interesting because they do not focus on damages. Rather, they look at the individual firm's contribution to global emissions and their duty to do their "fair share" to reduce them. In the Shell case, for example, the district court found that while the Paris Agreement is not binding on companies per se, they nevertheless have an obligation to comply with the emission reduction pathway established by the Intergovernmental Panel on Climate Change.

The Shell case is currently under appeal. But if the decision by the district court were to be affirmed by the highest court, it could establish a legal obligation under Dutch law for all corporates to proactively reduce their emissions in a way that is aligned with the objectives of the Paris Agreement. This would have major repercussions and would quite frankly be revolutionary. Such a duty is not currently priced into, nor part of, firms' business and transition plans. Up to now, the focus on liability risk has involved looking at actions for damages, and the assumption has been that this risk is somewhat remote, because causation has been difficult to establish. This assumption may turn out to have provided a false sense of security. First, because attribution science may make it easier to prove causation.<sup>20</sup> And second, because Shell-like "fair share" cases take a different approach and don't need proof of causation.

In any event, these cases pose obvious risks for the financial sector. Companies may face significant direct and indirect financial losses. We are not only talking about the costs of damages, fines, legal costs and the impact on the company's share price.<sup>21</sup> There could also be potential risks to a company's viability if a ruling were to result in unexpected adaptation costs or outright stranded assets that had not been priced in. Such a ruling would have an impact on the defendant in the specific case, other companies in the same sector and the banks that finance them.<sup>22</sup>

---

<sup>17</sup> The case is so significant that it will be immortalised in song at the Dutch National Opera next spring.

<sup>18</sup> Including both its own emissions and end-use (i.e. scope three) emissions.

<sup>19</sup> Greenpeace Italy et. Al. v. ENI S.p.A., the Italian Ministry of Economy and Finance and Cassa Depositi e Prestiti S.p.A. For further resources, see the Global Climate Change Litigation database.

<sup>20</sup> Attribution science attributes the detrimental impacts of climate change to the actions of an individual entity. In a lawsuit this can help to establish both standing and causation. See Stuart-Smith, R.F., Otto, F.E.L. and Wetzler, T. (2022), "Liability for Climate Change Impacts: The Role of Climate Attribution Science", in De Jong, E.R. et al. (eds.), *Corporate Responsibility and Liability in Relation to Climate Change (Intersentia 2022)*, 30 September.

<sup>21</sup> Sato, M. et al. (2023), "Impacts of climate litigation on firm value", *Working Papers*, Grantham Research Institute on Climate Change and the Environment, 23 May.

<sup>22</sup> Solana, J. (2020), "Climate change litigation as financial risk", *Green Finance*, Vol. 2, No 4, pp. 344-372; Setzer, J., Higham, C., Jackson, A. and Solana, J. (2021), "Climate change litigation and central banks", *Legal Working Paper Series*, No 21, ECB, December.

## 4 The next frontier: banks and the financial sector

However, banks will not only be affected indirectly – they may well be sued directly, too. In fact, this is already happening. Litigants are turning their attention to the financial sector, with the idea that if they sue the banks, they can “turn off the taps” of funding to high emitters.<sup>23</sup>

We are already seeing the first examples. There have been cases brought against financial institutions for greenwashing, as well as cases brought against the trustees of pension funds. We have even seen the first case taken directly against a bank under corporate due diligence legislation in France for its role in financing the expansion of fossil fuels.<sup>24</sup>

And we can't exclude that, in some jurisdictions, litigants will go for the jugular. Like in the Shell case, they could argue that banks also have a duty of care under civil law to protect fundamental rights – and that they must have plans in place to reduce emissions in line with the Paris Agreement and the European Climate Law. In other words, plans to reduce their emissions by 55% by 2030, compared with 1990 levels, and to immediately stop financing new fossil fuel exploration.<sup>25</sup>

## 5 Who is bringing climate litigation?

Part of the reason we must take this risk seriously is because the litigants – in these cases the plaintiffs – have proven to be serious players. Most cases are brought (or supported) by NGOs. We aren't talking about activists turning up outside courtrooms with cardboard placards. No, the litigants in these cases are sophisticated and use their transnational networks to build precedents across borders. They are well funded, well connected and well organised.<sup>26</sup> And they can – and do – hire the best and brightest lawyers in the field.

## 6 How can banks address climate-related litigation risk?

Let me now turn to the practical part of this speech – or the **homework**, if I may again draw on the “back-to-school” analogy. How can banks properly address and mitigate climate-related litigation risk? And how can prudential supervisors guide them?

There are two strands of thought here.

---

<sup>23</sup> See footnote 12.

<sup>24</sup> Notre Affaire à Tous Les Amis de la Terre, and Oxfam France v. BNP Paribas.

<sup>25</sup> Heemskerck, P. and Cox, R. (2023), “Bancaire klimaataansprakelijkheid onder invloed van duurzaamheidswetgeving”, *Maandblad voor Vermogensrecht*, No 3, pp. 93-106.

<sup>26</sup> Peel, J. and Markey-Towler, R. (2021), “Recipe for Success?: Lessons for Strategic Climate Litigation from the Sharma, Neubauer, and Shell Cases”, *German Law Journal*, Vol. 22, No 8, pp. 1484-1498; Hodgson, C. (2023), “The money behind the coming wave of climate litigation”, *Financial Times*, 5 June.

**The first is the bread-and-butter guidance.** In 2020 the ECB published its Guide on climate-related and environmental risks.<sup>27</sup> This guide contains several expectations that can help to address climate-related litigation – within existing categories of risk. These include the need to evaluate litigation risks, define tasks and responsibilities relating to climate risk and conduct climate-related due diligence. With its 2022 thematic review<sup>28</sup>, the ECB went a step further, setting institution-specific remediation timelines for meeting the expectations by the end of 2024, including intermediate deadlines of the end of last March and the end of this year. We also provided a compendium of good practices implemented by supervised banks, including practices to address climate and environment-related litigation risks.<sup>29</sup>

I recently asked the CEOs of some of our supervised banks to do me (and themselves) a favour. I suggested to ask their general counsels how closely they are following developments in climate and environment-related litigation. Is Urgenda a household name? Has the Shell case been analysed in depth, and have the possible repercussions for the bank been discussed in detail in board meetings? Have the avenues for possible direct litigation against banks been considered? Has the coverage of personal liability insurance for board members been checked in case their bank was found to be subject to the same obligations as Shell was in first instance and – second – in breach thereof? Today I will repeat this message to all CEOs, their general counsels, and to all executive and non-executive board members of the banks under our supervision: get up to speed with this trend and mitigate the associated risks for your institution.

Some banks have already started to consider climate-related liability risk, and a few have started to quantify possible losses. One example of good practice relates to how banks calculate a client's credit risk. Some include liability risk as a factor when rating their clients' probability of default to better price in this type of risk. Another bank assessed reputational risks, including those related to potential greenwashing and financing of polluting industries, by defining a set of scenarios and mapping the possible affected stakeholders and the profit and loss area that would be most affected. In a second step, the bank then used specific case studies to quantify the possible losses that could arise. Another good practice is to mitigate the risk of greenwashing by ensuring adequate disclosures, by considering this risk in the governance framework, and by conducting regular compliance checks.

Another positive example is that if, through its climate and environment-related due diligence exercises, a bank identified climate and environment-related litigation risks for its client (and thus potentially greater credit and reputational risk for the bank itself), it sets up an action plan to address these risks. This action plan could include asking the client to adopt best practices in its sector or, if this avenue is unsuccessful, limiting its business relationship with the client.

---

<sup>27</sup> ECB Banking Supervision (2020), *Guide on climate-related and environmental risks*, November.

<sup>28</sup> ECB Banking Supervision (2022), *Walking the talk: Banks gearing up to manage risks from climate change and environmental degradation*, November.

<sup>29</sup> ECB Banking Supervision (2022), *Good practices for climate-related and environmental risk management*, November.

**Supervisors have homework to do too.** The NGFS report on micro-prudential supervision of climate-related litigation risks published last Friday sets out additional potential options for supervision. It emphasises the need for supervisors to take a risk-based approach, which can include performing a materiality assessment of risks at the broader jurisdictional level or a more granular exposure analysis at entity level.

We shouldn't forget that central banks and supervisors may also be the targets of climate and environment-related litigation, either to ensure that they are doing their part to protect fundamental rights and facilitate compliance with the Paris Agreement or to ensure that they are fulfilling their duties in terms of financial stability or consumer and investor protection.<sup>30</sup>

## 7 The importance of Paris-aligned transition plans

**The second strand of thought is the well-known saying “if you fail to plan, you plan to fail”.** Banks need to be aware that in certain jurisdictions the impact of climate-related litigation could dig right down into the viability of their business models. And given the determination of the NGOs, and their knack for forum shopping – choosing the jurisdiction most likely to provide a favourable verdict –, we don't know how many banks they will be aiming for. **To address this source of litigation risk, the best advice I can give is that banks should start putting in place their Paris-aligned transition plans.**

By this, I don't mean a slick advertising campaign with glossy photos of rainforests – that is just a recipe for greenwashing accusations. I mean realistic, transparent and credible transition plans that banks can and actually do implement in a timely manner. Having such plans in place requires banks to ensure they have accurate, granular data; that they conduct a robust materiality assessment; that they integrate transition planning into their internal discussions and strategic decision-making and that they establish proper internal governance to this effect. With these elements in order, banks should be able to communicate how they are positioning themselves throughout the transition to a climate-resilient and sustainable economy. This would demonstrate the degree to which they are doing their “fair share”. Moreover, a transparent and credible transition plan should enable stakeholders to fully understand the risk environment in which a bank operates. Therefore, clearly articulating the processes and actions related to the transition plan should also significantly contribute to reducing litigation risk.

This is particularly important when we look at the feedback loop between climate and environment-related legislation and litigation.<sup>31</sup> It is only a matter of time before bank transition plans become mandatory under EU law. There are now three pieces of legislation in the pipeline that will require banks to put transition plans in place: the Corporate Sustainability Reporting Directive, the proposed Corporate Sustainability

---

<sup>30</sup> See, for example, ClientEarth v. Financial Conduct Authority and ClientEarth v. Belgian National Bank.

<sup>31</sup> See footnote 12.

Due Diligence Directive and the recent Capital Requirements Directive proposal.<sup>32</sup> This new legislation alone could prompt further climate litigation, with litigants finding additional legal bases for their claims.

**Of course, no one – not supervisors, not legislators, and not the courts – can expect individual companies or banks to single-handedly solve the climate crisis.** However, based on emerging case-law and the ever-more stringent legislation on transition plans, we can no longer afford the luxury of simply assuming that individual companies do not have a duty to do their “fair share” in the fight against climate change. Banks and supervisors alike must – if only as a precaution – manage the risk of the higher courts finding that this is already a binding duty today.

## 8 Environment-related litigation

One last point: today I have mainly used the phrase climate-related litigation, which is focused on reducing greenhouse gas emissions. But we shouldn't be blind to other trends, such as the rise in environment-related litigation more broadly. As alarm at the decline in nature and biodiversity grows – with some considering that humanity has become a weapon of mass extinction<sup>33</sup> – we can expect litigants to turn to the courts, drawing inspiration from their successes in the area of climate. There have already been several cases seeking to hold supermarkets, food producers and even a bank accountable for deforestation in the Amazon.<sup>34</sup> This trend is likely to gather momentum as legislation on supply chains enters into force – the Deforestation Regulation and the proposed Corporate Sustainability Due Diligence Directive being two key examples. And arguments about companies' duty to do their “fair share” to protect fundamental rights by reducing greenhouse gas emissions could also be applied to mitigating other types of environmental degradation.

## 9 Conclusions

Let me conclude.

We have arrived at the horizon of the climate crisis, and at the horizon of climate and environment-related litigation risk. Banks still have a lot of homework to do to address this risk, in terms of both meeting the ECB's supervisory expectations and putting transition plans in place.

This is all the more important given that litigants may increasingly target banks and the wider financial sector, with the aim of driving funding away from carbon-intensive

---

<sup>32</sup> NGFS (2023), *Stocktake on Financial Institutions' Transition Plans and their Relevance to Micro-prudential Authorities*, May. See also Opinion of the European Central Bank of 6 June 2023 on the proposal for a Directive on corporate sustainability due diligence (CON/2023/15) (OJ C 249, 14.7.2023, p. 3).

<sup>33</sup> Guterres, A. (2022), “Secretary-General's remarks at the UN Biodiversity Conference – COP15”, 6 December.

<sup>34</sup> Comissão Pastoral da Terra and Notre Affaire à Tous v. BNP Paribas.

sectors and towards the transition. We need to take action now to anticipate and mitigate this source of risk.

But I would like to end on a more personal note by returning to the legal professionals that have gathered here today.

Lawyers might sometimes see themselves as the upholders of tradition rather than the drivers of change. They might not necessarily see their work – with pen and paper, in front of a computer or in the courtroom – as having a dramatic physical impact on the world, much less saving the planet. But with climate and environment-related litigation, it's different. The lawyers involved in these cases – be it as counsel, judges, or academics – see that urgent change is needed to protect humanity, by holding society to the commitments of the Paris Agreement, and to protect citizens' fundamental rights, using the rule of law to achieve these goals.

It brings to mind the poem "Digging" by Seamus Heaney, in which he reflects on whether his creative endeavours could bring the same value to society as his ancestors' work digging the land to plant and harvest food. He reflects on how to balance his wish to honour his forebears with his drive to follow his own way, using a pen instead of a spade. Heaney concludes: "Between my finger and my thumb, The squat pen rests. I'll dig with it."

Lawyers today are also taking up their pens to support the world on a Paris-aligned path. Their pens set in motion the pens of judges. And the pens of judges may well induce real change. Banks must manage all their material risks, including their climate and environmental related litigation risks. Come hell or high water.







## Part II

# Independence, accountability and proportionality in the context of the ESCB's secondary mandate

# Independence, accountability and proportionality in the context of the ESCB's secondary mandate: an introduction

Philip R. Lane\*

In this contribution, I will provide my own perspective, from a monetary policy point of view, on some aspects of the topic of this panel: the independence of the ECB; its accountability; and the proportionality of its actions in the context of the ESCB's secondary mandate.

The appropriate starting point is the primary objective of the ECB, which is to maintain price stability in the euro area. In addition to the primary objective, the Treaty on the Functioning of the European Union also stipulates that, without prejudice to the price stability objective, the Eurosystem shall support the general economic policies in the EU with a view to contributing to the achievement of the Union's objectives as laid down in Article 3 of the Treaty. These objectives include balanced economic growth, a highly competitive social market economy aiming at full employment and social progress, and a high level of protection and improvement of the quality of the environment. The Eurosystem shall also contribute to the smooth conduct of policies pursued by the competent authorities relating to the prudential supervision of credit institutions and the stability of the financial system.

The Treaty does not provide a precise definition of what is meant by maintaining price stability. Our monetary policy strategy, which we updated in July 2021, lays out how we deliver on this mandate. Our strategy sets out an appropriate set of monetary policy instruments, indicators and intermediate targets, as well as how to take into account other considerations without prejudice to price stability. The previous review of the ECB monetary policy strategy had taken place in 2003, almost two decades ago. In view of this time gap, the 2021 review was designed to start from a clean state to work out how our monetary policy should be organised. The conclusions of this review, which are contained in the monetary policy statement of the ECB and the accompanying overview note, provide a rich resource for the thinking of the Governing Council on many of these issues.<sup>35</sup>

The first point to make is that the way in which monetary policy is conducted depends on the inflation environment. When the threat to price stability was inflation running too far below the target (which is now set at two per cent as a result of the review), it was necessary to turn to additional instruments, since interest rates had already been reduced to close to the effective lower bound; interest rates cannot go too negative for

---

\* Member of the Executive Board of the European Central Bank.

<sup>35</sup> The ECB also released the eighteen Eurosystem staff background papers that provided the analytical support for the strategy review.

a host of reasons. These instruments included asset purchases programmes and targeted longer-term refinancing operations. This comprehensive package of mutually reinforcing monetary policy measures was deployed to deliver on price stability.<sup>36</sup> At the same time, deploying a mix of instruments can open up the possibility to take into account secondary objectives, since the additional instruments create some extra optionality in how the combination of these instruments are calibrated. In contrast, the current challenge is that inflation is too far above the target. As agreed in the strategy review, the policy rate is the primary tool when inflation is above the target and the effective lower bound is not a constraint. With the policy rate the predominant active tool, monetary policy is inescapably more constrained in terms of contributing to secondary objectives.<sup>37</sup>

That said, while asset purchases and credit-easing lending operations are no longer an active monetary policy tool – the portfolio of our regular asset purchase programme (APP) is declining at a measured and predictable pace, the pandemic emergency purchase programme (PEPP) portfolio is being reinvested until end-2024, and the credit-easing lending operations are being phased-out and have already been repaid to a large extent – we still have a very large balance sheet. While the balance sheet remains large, even if it is shrinking, this does create some room for balance sheet policies, where it may be possible to take secondary objectives into account.

More than that, even once the balance sheet has reached its steady state, the operational framework for the implementation of monetary policy may provide scope to take into account secondary objectives. Central bank liquidity can be provided on one side through an outright portfolio of assets, where a degree of freedom may exist in relation to the distribution of assets in the portfolio. On the other side, central bank liquidity can be provided through collateralised lending operations to banks. So even under normal conditions, collateral policy, in the form of eligibility criteria and haircuts on collateral, for example, remains a very important area in which secondary objectives can be taken into account maybe.

In terms of the policy rate, the medium-term orientation of our monetary policy provides some flexibility to account for secondary objectives. The medium-term orientation of our monetary policy strategy allows for inevitable short-term deviations of inflation from the target, as well as lags and uncertainty in the transmission of monetary policy to the economy and to inflation. But the medium-term orientation also allows the Governing Council in its monetary policy decisions to cater for other considerations relevant to the pursuit of price stability. For example, the medium-term orientation provides flexibility to take account of employment in response to economic shocks giving rise to a temporary trade-off between short-term employment and inflation stabilisation, without endangering medium-term price stability.

---

<sup>36</sup> For a comprehensive review of the ECB's policy in this period, see Lane, P.R. (2021), "The monetary policy response in the euro area", in English, B., Forbes, K. and Ubide, Á. (eds.), *Monetary Policy and Central Banking in the Covid Era*, CEPR Press, London, March 2021, pp. 81-92.

<sup>37</sup> The design of the run-off phase of the accumulated asset portfolios and the design of the monetary policy operational framework (including the collateral framework) means that there are still important parameters that can be affected by the secondary objectives.

Similarly, the medium-term orientation also allows the ECB to take account of financial stability, where appropriate, in view of the interdependence of price stability and financial stability. When there are risks of instability, we can think of interventions that pull in the same direction, in terms of their support for financial stability on one side and price stability on the other side. The central bank interventions in March 2020 in response to the pandemic shock, or that of the Bank of England in the autumn of 2022, are cases in point.

In relation to the secondary objectives, we have spelled out in general in the strategy review how to take these into account. In one direction, taking such considerations into account will often be necessary to maintain price stability over the medium term. In the other direction, monetary policy measures have an impact on the economy and on economic policies. When taking secondary considerations into account, the Governing Council bases its assessment in particular on the relevance of these considerations for the ECB's primary objective and the ECB's ability to support the general economic policies in the Union, with a view to making a contribution to the attainment of the Union's objectives. For example, when adjusting its monetary policy instruments, the Governing Council will – provided that two configurations of the instrument set are equally conducive and not prejudicial to price stability – choose the configuration that best supports the general economic policies of the Union related to growth, employment and social inclusion, and that protects financial stability and helps to mitigate the impact of climate change, with a view to contributing to the objectives of the Union.

A concrete recent example where the Governing Council took into account secondary objectives in a proportionate manner is the adjustment of the remuneration of minimum reserve requirements. Specifically, in July 2023 the Governing Council decided to reduce the remuneration of minimum reserve requirements from the deposit facility rate to zero per cent. This change did not have direct implications for the monetary policy stance, as in the current conditions of ample liquidity, the interest paid on the reserves that banks hold in the ECB's deposit facility – that is, reserves beyond the minimum required level – is the Governing Council's main instrument for setting the monetary policy stance in its fight against inflation. Accordingly, the decision to reduce the remuneration on minimum reserves preserved the effectiveness of monetary policy by maintaining the current degree of control over the monetary policy stance and ensuring the full pass-through of the Governing Council's interest rate decisions to money markets. At the same time, it will improve the efficiency of monetary policy by reducing the overall amount of interest that needs to be paid on reserves in order to implement the appropriate stance.

Finally, in relation to climate change, it is important to note that the implications of climate change and transition policies to address it are absolutely front and centre of the primary mandate.<sup>38</sup> As the monetary policy cycle foresees meetings to take place eight times a year, the analysis of weather shocks and their implications for the economy and the inflation outlook is a regularly recurrent feature. Whereas at this level the analysis of climate-related issues is part of the monetary policy cycle, another level relates to the fact that climate change is associated with significant tail risks, which

---

<sup>38</sup> As part of the outcome of the strategy the ECB published a detailed climate action plan.

can linger over a long horizon. The eruption of the global financial crisis in 2008 is a case in point, where tail risks materialised and where greater investment in prevention ten years before that could have gone a long way in mitigating these risks. The decisions (or non-decisions) of policymakers can have consequences for decades. It follows that it is important to take the right measures to prevent tail risks that could materialise far in the future.

# Proportionality in German constitutional law

Alexander Thiele\*

## 1 The general perception of central banks and the ECB

Questions about the primary, or perhaps exclusive, role of central banks, including the European Central Bank (ECB), have traditionally elicited a consensus among individuals, particularly economists, emphasising the safeguarding of price stability. In fact, at least until a few years ago, even the ECB itself would have promptly provided a similar answer. When taking a closer look, however, this obvious reply has never been the completely correct one, neither historically nor when looking at the concrete mandates of modern central banks.<sup>39</sup>

Certainly, historically the first modern central banks – not least the Bank of England in 1694 – were founded for a very different and quite mundane reason: money. In financially difficult times, they were supposed to safeguard the necessary financial resources for the State.<sup>40</sup> Alexander Hamilton, Secretary of the Treasury under President George Washington, justified the founding of the first Bank of the United States in 1791 for similar reasons. He expected support by the bank “in obtaining pecuniary aids, especially in sudden emergencies.”<sup>41</sup> It was only during the 19<sup>th</sup> century that these “Banks of the Government” slowly transformed themselves into “Banks of the Banks”, generally granting the necessary liquidity to the national economy and the slowly emerging financial markets whilst safeguarding the stability of the currency by ensuring its convertibility into gold and stepping in in times of crisis as lender of last resort. “My customers give their money to me, and look to me for it; I do the same to the Bank [of England]”, as the banker Vincent Stuckey put it in 1832. Indeed, since then the main objective of central banks (with diverging focal points) became more and more safeguarding price stability.<sup>42</sup> It was this commonly agreed main task that finally triggered a broad debate on the appropriate institutional status for such a bank. The final result is well-known; since the 1990s, central bank theory practically rests on two pillars: central banks safeguard price stability and must be institutionally independent in order to effectively do so.

---

\* Professor for state theory and public law at the Law Faculty of the BSP Business and Law School in Berlin.

<sup>39</sup> See for the ECB Petit, C. A. (2022), “The ECB Mandate – a Comparative Constitutional Perspective, in: Beukers, T., Fromage, D. and Monti, G. (eds.), *The New European Central Bank*, Oxford University Press, Oxford, pp. 361 ff.

<sup>40</sup> See for the Bank of England Feavearyear, A. E. (1931), “The Pound Sterling”, Clarendon Press, Oxford, p 125: “Finally, and almost as a last resource, they founded the Bank of England.”

<sup>41</sup> *Hamilton, A.* (1983), “Report on a National Bank”, in: H. E. Kroos (ed.), *Documentary History of Banking and Currency in the United States*, Chelsea House Publishers, Washington, pp. 231 ff.

<sup>42</sup> *James, H.* (2012), “Making the European Monetary Union”, Harvard University Press, Boston, p. 15.

In the years to come, this theory became so dominant that both its elements (at least to some) appeared as somewhat natural and thus unchangeable necessities for any central bank, notwithstanding the concrete mandate laid down in the respective statutes – although these statutes regularly listed quite a few other tasks for a central bank to pursue apart from merely safeguarding price stability. The Federal Reserve System for instance has a much broader mandate. Clearly, the same is true for the ECB. Nonetheless, the fact that Article 127 of the Treaty on the Functioning of the European Union (TFEU) actually obliges it to support the general economic policies in the Union with a view to contributing to the achievement of the objectives of the European Union (EU) as laid down in Article 3 of the Treaty on European Union (TEU), was more or less neglected completely. Until today, the ECB has not founded a single action on this secondary mandate,<sup>43</sup> neither did the academia, where at least until a few years ago hardly any article took a closer and in-depth look at what this part of its mandate might cover and how it could be implemented into a broader monetary policy. As this so-called secondary mandate was finally rediscovered in the aftermath of the financial crisis, and in connection with the question of how central banks might be integrated into the fight against climate change, we thus find ourselves in a somewhat uncomfortable situation. We would obviously like to activate the secondary mandate and use its potential for the achievement of certain goals, but have no robust idea of what it actually encompasses, what instruments it allows for and how all this might be influenced by the institutional independence the ECB enjoys according to Article 282 (3) TFEU.

In this contribution, I would like to focus on the last of these questions, namely the relationship between the secondary mandate and the independent status of the ECB, as I believe that the answer to this question will necessarily influence the answers to all the others. In other words, the question what the secondary mandate actually encompasses and what instruments it allows the ECB to implement cannot be answered without knowing how independent the ECB actually acts when it reverts to its secondary mandate of supporting the general economic policies in the Union.

I will start by briefly recalling the general justification and the different forms of independence before analysing possible consequences for the secondary mandate. In order to effectively make use of the secondary mandate, I will finally propose to distinguish between two different degrees of independence: a strict independence as regards the primary mandate, and a somewhat milder kind of independence as regards the secondary mandate. Article 282 (3) TFEU thus requires the ECB to be formally independent in all its actions, but the scope of this independence varies according to the mandate it reverts to in the concrete situation.

---

<sup>43</sup> For the reasons see van't Klooster, J. and de Boer, N. (2022), "What to do with the ECB's Secondary Mandate", *Journal of Common Market Studies*, No 1, p. 13: "While focusing narrowly on its objective of price stability, until recently monetarist orthodoxy has led the ECB to all but ignore its secondary mandate."



## 2 Justification and forms of independence<sup>44</sup>

### 2.1 The general justification of central bank independence

The independent status of central banks, in general, and the ECB, in particular, appear so natural to most of us that we sometimes forget that – at least in a democratic order – such a status needs a specific justification. Indeed, as central banks perform duties of public administration with potentially major impacts on people's (economic) lives, integrating these institutions into the hierarchical organisation of administration appears far more self-evident. We would obviously not consider granting the Ministry of Finance such a status, and as mentioned above, the first central banks were also not supposed to be independent from political influence. On the contrary, serving as "Banks of the State" being independent from this state did not appear to be a very sensible institutional setting. The idea that central banks should enjoy some sort of independence from political institutions – and especially the government – is therefore younger than one might think. It came up only in the middle of the 20<sup>th</sup> century due to the central bank's – now broadly accepted – general task of safeguarding price stability. The question that came up was the following: can a central bank perform this specific task effectively as long as it is integrated into and thus dependent on (or even controlled by) the government? At first, this question was discussed more or less openly. However, in the 1980s the pendulum slowly began to swing towards the supporters of independence (with a trendsetting paper by Kenneth Rogoff), and by the early 1990s the necessity of central bank independence in order to avoid possible conflicts of interests advanced to be one of the central pillars of modern central bank theory – and actually still is today (even though it has been questioned regularly in recent years). Therefore, it comes as no surprise that the ECB was created according to this new paradigm in the late 1990s – some even declaring it to be the "most independent central bank of all."<sup>45</sup>

From a democratic perspective, we therefore find a justification for the independent status by specific task with the following argument: if there is indeed a relationship between safeguarding price stability and independence, we cannot transfer the task of safeguarding price stability onto a central bank while at the same time denying it the necessary institutional status to perform successfully. In other words – and this is obviously important when analysing the scope of the secondary mandate, it is not central banks in general that need to enjoy an independent status, but only central banks equipped with the task of safeguarding price stability, and only as far as this specific task is concerned. Central banks are independent because, and as far as, they safeguard price stability. The justification for this status lies solely in possible conflicts of interest and not in the special expertise or competence of the relevant central bankers.

---

<sup>44</sup> See in detail Thiele, A. (2022), "The Independence of the ECB", in: Beukers, T., Fromage, D. and Monti, G. (eds.), *The new European Central Bank*, Oxford University Press, Oxford, pp. 238 ff.

<sup>45</sup> Hayo, B. and Hefeker, C. (2002), "Reconsidering Central Bank Independence", *European Journal of Political Economy*, No 4, p. 654.

This specific interrelation explains why many (and especially German) scholars are so sceptical when it comes to transferring further tasks onto an independent central bank. Such tasks will usually not require an independent status for being fulfilled effectively. Concerning these tasks, we are thus confronted with a possible deficit of democratic legitimacy. The fact that especially the German Constitutional Court looks somewhat sceptical at the secondary mandate of the ECB therefore comes as no surprise. According to its view, supporting general economic policies (for instance fighting climate change) is simply nothing an independent central bank should be doing at all, as such decisions should only be taken by strictly accountable political institutions.

## 2.2 Manifestations of independence

Before delving into the consequences this insight might have for the interpretation of the ECB's secondary mandate, it appears important to briefly assess what 'independence' actually stands for. Independence can manifest itself in very different forms; there is no such thing as 'the' independence that either prevails or not. Independence is always a question of degree. The only thing excluded in any case is the possibility of subjecting an independent institution to direct and binding instructions – this is the core meaning of Article 282 (3) TFEU when it states that EU institutions, bodies, offices and agencies and the governments of the Member States shall respect the ECB's independence. Article 130 TFEU indeed explicitly prohibits such instructions. Apart from this, however, the independence of a central bank can take very different forms, and in this sense central banks worldwide vary quite significantly as concerns the scope of their independence. Indeed, some independent central banks appear to be more dependent (or less independent) than others. As regards modern central banks, we can thereby distinguish between the following three manifestations of independence:

- *goal independence*. It grants the central bank the authority to define and interpret its monetary objectives autonomously without interference by third parties, especially the government. However, this form of independence is not to be misinterpreted as giving the central bank complete freedom as to which monetary policy goal(s) to pursue. In fact, the general monetary policy goals are assigned to the central bank normatively by statute (and as the ECB is concerned in the Treaties). Goal-independence thus allows a central bank not to choose, but to autonomously interpret these goals and formulate its understanding of its concrete mandate. As regards the ECB, goal-independence would allow it to formulate not only its understanding of price-stability, but also the concrete content of its secondary mandate without interference by third parties. It would therefore be able to determine what economic policies to support, and also how to do so.
- *goal-choice independence*. It allows a central bank to choose autonomously from a certain catalogue of assigned goals, and to decide which of these goals to pursue with priority depending on the current economic conditions. For instance, this is a form of independence we find with the Federal Reserve System but not the ECB. The ECB has to pursue its core purpose – price stability – with priority

and, according to Article 127 TFEU, it is only allowed to support the economic policy in the Union as long as this core purpose is not infringed. Considering the above-mentioned deficit of legitimacy when it comes to the secondary mandate, complete goal-choice independence would in fact most certainly not be acceptable from a German constitutional perspective.

- *instrumental independence*. It enables a central bank to autonomously decide on the instruments it deems most fitting to reach the general monetary policy goals. Usually we will, however, find a certain instrumental mix laid down in the relevant legal statutes the central bank may revert to. This instrumental mix will usually be quite broad and not necessarily exclusive (see Article 20 of the ECB's Statute), allowing the central bank to react to the countless possible economic surroundings and developments. Restrictions will mostly be introduced by a catalogue of generally forbidden instruments (see for instance Article 123 TFEU). Instrumental independence also includes the right of a central bank to decide on its specific monetary policy strategy – all central banks have indeed developed their own strategy recognising the specific economic characteristic of their monetary area.

### 3 Consequences for the secondary mandate of the ECB

What follows from these first and general insights into the relationship between mandate and independence for the interpretation and the possible scope of the secondary mandate of the ECB? How does the independent status influence what the ECB may or may not do when wanting to support the economic policies in the Union according to Article 127 TFEU, and especially the European fight against climate change?

#### 3.1 The general deficit of legitimacy

Within a democratic order, the independent status of any institution requires a specific justification as it significantly reduces the respective democratic legitimacy and accountability. Therefore, the first questions to answer are the following: can we find such a justification as concerns the secondary mandate? Are there good reasons to assign the task of supporting the economic policies in the Union to an independent central bank? From a democratic perspective the answer – unfortunately – is simple: no. The successful execution of economic policy of any sort does not inherently demand independence from political authorities. On the contrary, its highly political and controversial character generally requires it to be vested in an institution that is directly accountable to the people. Similarly, Jens Van 't Kloosters and Nik de Boer conclude that “[t]he ECB cannot give content to its highly indeterminate treaty provisions without itself making economic policy. However, for the ECB to simply cherry-pick its own secondary objectives lands it in deep political waters, raising

severe legal and democratic objections.<sup>46</sup> In contrast to the task of price stability, the central bankers cannot even point to some sort of special expertise they might enjoy when it comes to economic policies that could justify their independent status (even though such a justification by expertise is generally problematic from a democratic perspective). Of course, the ECB is only obliged to “support” the economic policies in the Union. That might lessen the problem, but does not solve it entirely; how and when to support what specific element of the wide range of economic policies within the EU<sup>47</sup> will again be highly controversial from a political perspective. The fact that the ECB sees itself merely as a policy-taker and not a policy-maker thus might be – at least to a certain degree – a fitting description of its actions, but does not make these ‘takings’ as such completely unpolitical.<sup>48</sup> As a consequence, the ECB lacks the required democratic legitimacy when it reverts to its secondary mandate. However, as the secondary mandate is formally integrated into the Treaties themselves, it can hardly be interpreted as generally breaching the European democratic principle. In fact, even the German Constitutional Court has generally accepted it, at least under certain conditions. However, this does not change the fact that any democratic order is vested in the acceptance of its citizens and that this acceptance requires the institutional order to grant sufficient participation. The question therefore is not whether the ECB can revert to its secondary mandate at all – of course it can. The decisive question is rather in what form and to what extent it can do so when taking this general lack of democratic legitimacy into account. Two approaches appear conceivable, the first based on the scope of the mandate and the second on the scope of independence.

### 3.2 Solution 1: (very) restrictive interpretation of the secondary mandate

The first solution to the lacking democratic legitimacy would be to take the above-mentioned independent status of the ECB for granted and to interpret the secondary mandate as restrictively as possible. This could ensure the necessary acceptance of the measures taken but, unfortunately, would at the same time render the secondary mandate practically negligible, since the ECB would be more or less hindered to actively revert to the secondary mandate at all, yet alone to take politically highly contested measures of any sort. In terms of content, the mandate would thus be practically limited to prohibiting the ECB from actively harming economic policies in the EU through monetary measures. The ECB would have to implement possible economic consequences into its monetary policy, but it would not be able to pursue any form of active economic policy, even if this were not accompanied by any risks to price stability. When the secondary mandate was formulated in the late 1990s, most of the German participants might actually have had such a restrictive interpretation in mind, since the wording of the Treaties was – and this might come as a surprise – taken directly from the former statute of the German Bundesbank. According to section 12 BBankG, the Bundesbank was obliged to support the general economic policy of the German government if and as far as this was compatible with its monetary policy.

---

<sup>46</sup> Van 't Klooster, J. and De Boer, N. (2022), “What to do with the ECB's Secondary Mandate”, *Journal of Common Market Studies*, No 1, p. 13.

<sup>47</sup> *ibid.*, p. 4.

<sup>48</sup> See also *ibid.*, p. 9: “In the absence of clear instructions on what to do, there are serious democratic concerns over monetary policy objectives selected by the ECB alone.”

As with the ECB, this part of its mandate played no active role in its monetary actions, and was more or less interpreted as simply expressing the fact that Bundesbank and government were no political enemies and should thus not work against each other. Having this history in mind, it comes as no surprise that such a restrictive interpretation of the secondary mandate is the one the German Constitutional Court prefers. In its various decisions dealing with the ECB, it has regularly pointed out that the independent status directly leads to a restrictive interpretation not only of the secondary but even of the primary mandate. In its famous Public Sector Purchase Programme-decision, it concluded in marginal 143:

“[i]t is furthermore imperative that the mandate of the ESCB be subject to strict limitations given that the ECB and the national central banks are independent institutions (Art. 130, Art. 282(3) third and fourth sentence TFEU, Art. 88(2) GG), which means that they operate on the basis of a diminished level of democratic legitimation. The independence afforded the ECB relates only to the powers conferred upon it in the Treaties and the substantive exercise of such powers but is not applicable with regard to defining the extent and scope of the ECB’s mandate. To ensure that the ECB cannot validly adopt a programme that, contrary to the principle of conferral, exceeds the monetary policy mandate vested in the ECB under primary law, it is imperative that adherence to limits of the ECB’s competence be subject to full judicial review (cf. BVerfGE 89, 155 <207 et seq ., 211 and 212>; 134, 366 <399 and 400 para. 59>; 142, 123 <219 et seq . para. 187 et seq .>; 146, 216 <278 paras. 102 and 103>; BVerfG, Judgment of the Second Senate of 30 July 2019 - 2 BvR 1685/14, 2 BvR 2631/14 -, paras. 134, 139, 211). It is incompatible with this restrictive interpretation, which is mandated under German constitutional law, to interpret the specific conferral of monetary policy competences in a manner that, in the context of asset purchases, regards the mere assertion of monetary policy objectives as sufficient while disregarding as irrelevant the economic and fiscal policy effects of the PSPP for both the delimitation of competences and the proportionality assessment, even where such effects are foreseeable, knowingly accepted or might actually be (tacitly) intended.”

Furthermore, concerning the ECB’s secondary mandate it clarified in marginal 163:

“[t]he interpretation of the ECB’s monetary policy mandate, as undertaken by the CJEU, encroaches upon the competences of the Member States for economic and fiscal policy matters. With few exceptions (cf. Arts. 121 and 122, Art. 126 TFEU), the competence of the European Union in economic policy matters is essentially limited to coordinating the policies of the Member States (Art. 119(1) TFEU). The ESCB is to merely support the general economic policies in the European Union (Art. 119(2), Art. 127(1) second sentence TFEU; Art. 2 second sentence ESCB Statute); it is not, however, authorised to pursue its own economic policy agenda. To the extent that the Weiss Judgment of the CJEU essentially affords the ECB the competence to pursue its own economic policy agenda by means of an asset purchase programme, and refrains from subjecting the ECB’s actions to an effective review as to conformity with the order of competences on the basis of the principle of proportionality, including a balancing of the economic and fiscal policy effects of the PSPP against its monetary policy objective, the Judgment of the CJEU exceeds the judicial mandate deriving from Art. 19(1) second sentence TEU (cf. also BVerfGE 126, 286 <306>). The CJEU thus

acted *ultra vires*, which is why, in that respect, its Judgment has no binding force in Germany.”

Therefore, the German Constitutional Court has limited the secondary mandate to an absolute minimum, and it would stand in opposition to any interpretation that might allow the ECB to pursue any form of economic policies that might have an effect on the redistribution of wealth or – even stricter – any economic agenda at all. This is bad news for the ECB’s attempts to activate its secondary mandate for the fight against climate change. The necessary transformation to a CO<sub>2</sub>-neutral economy is highly political, and it necessarily affects the distribution of wealth and to some extent the way we want to live and work as a community. The independent ECB getting involved in any of these matters is thus nothing the German Constitutional Court would accept, despite the fact that we have seen a significant personal turnover in its competent second chamber in the last years.

### 3.3 Solution 2: (very) restrictive interpretation of the ECB’s independence

This restrictive interpretation of the secondary mandate is a direct consequence of the specific independent status the ECB enjoys. Since the ECB is so independent, any form of political action would lead to acceptance problems and thus endanger the functionality of the ECB as a whole, which is why it is necessary to restrict the scope of its secondary mandate. However, instead of restricting the secondary mandate, one might also think of restricting its independent status if – and as far as – the ECB reverts to this part of its mandate. The scope of the secondary mandate could then be widened as far as the independent status is restricted, since the ECB would thereby gain democratic legitimacy. Such a restriction would obviously only relate to the secondary and not to the primary mandate. The term ‘independence’ in the Treaties would thus be interpreted differently according to which part of the mandate the ECB would be making use of in the concrete situation. The ECB would enjoy a wider degree of independence when it reverts to its primary mandate, and a narrower degree when it reverts to its secondary one.

From a dogmatic point of view, such a different interpretation may at first seem problematic – after all, the same term and the same Treaty articles are involved in each case. Nevertheless, there are good reasons for such a differentiation. First, as explained, there is a close link between independent status and specific mandate. Independence is clearly a direct consequence of the primary mandate. It therefore does not seem too far-fetched to generally interpret the term ‘independence’ in a mandate-related manner, and in any case not to disregard the specific mandate under consideration when deciding on the scope of independence. This applies even more as the concept of independence is by no means unambiguous in terms of content, but – as explained above – rather permits a whole range of different interpretations. Of course, the minimum requirements for an independent institution must not be undercut in this case either. Direct instructions from other EU authorities would therefore be prohibited also with regard to the secondary mandate. However, it would nonetheless be possible to tie the ECB’s actions more closely to the political institutions, not least

the European legislator.<sup>49</sup> The greater the extent to which such a tie-back, and thus at the same time greater political involvement, would be possible and actually succeed, the more the ECB would then be able to draw on its secondary mandate without having to fear the acceptance problems mentioned above due to its lacking democratic legitimacy.

What form could such a stronger political tie-back of the ECB take in detail? One of the central criticisms of the second mandate is undoubtedly its vague scope. In this respect, Article 127 TFEU refers comprehensively to the very broad and open catalogue of objectives in Article 3 TEU. Within the framework of its otherwise existing goal independence, the ECB has – at least in theory – considerable scope for concretisation, and thus the possibility of pursuing an independent economic policy agenda. “The mandate, accordingly, provides the ECB with a lot of leeway in deciding how to support economic policy; it must distil the general direction not just from EU-wide policies but also from those pursued by the different member states.”<sup>50</sup> It is precisely here that the greatest concerns in terms of democratic theory are likely to arise – and we can see also why the differentiation between ‘policy-taker’ and ‘policy-maker’ does not help to solve the general problem of legitimacy. In this respect, one could thus think of limiting the ECB’s general goal independence by having the concretisation and specification of the secondary mandate carried out by another body, namely the European legislature. In fact, the Treaty contains comparatively few provisions for the legislature with regard to the independence of the ECB. Direct instructions to the ECB are out of the question for the legislature anyway, and Article 282 (3) TFEU merely obliges it to “respect” the independence of the ECB.

In this respect, amending the ECB’s Statute, which specifies its monetary policy activities and the instruments to be used, should be considered first. At this point, the content and scope of the secondary mandate could be defined in more detail. However, since the Statute is adopted as a protocol pursuant to Article 129 (2) TFEU, and is therefore to be assigned to primary law pursuant to Article 51 TEU, such an adjustment of the Statute would require an amendment to the Treaty and thus unanimity among the Member States. Taking into account the independence of the ECB, such a procedure would be as possible as it would be improbable and, in any case, not feasible in practice. Article 129 (3) TFEU at least opens up the possibility of modifying certain provisions of the Statute in the ordinary legislative procedure. However, these do not include the provisions on the concretisation of the mandate.

This brings us to Article 121 (2) TFEU.<sup>51</sup> According to this Article, the Council, on a recommendation from the Commission, shall prepare a draft for the broad guidelines of the economic policies of the Member States and of the EU and shall report thereon to the European Council, which, on the basis of this report, shall discuss a conclusion on the broad guidelines of the economic policies of the Member States and of the EU. Subsequently, it is again the Council which, on the basis of this conclusion, adopts a recommendation setting out these broad guidelines. So far, these Council

---

<sup>49</sup> Similarly, *ibid.*, pp. 10 ff.

<sup>50</sup> *ibid.*, p. 4.

<sup>51</sup> See also *ibid.*, p. 12. It is true, however, as the authors point out, that the limited involvement of the European Parliament is downside of this solution. It could nonetheless be a first step towards an increased legitimacy of the ECB when reverting to its secondary mandate.

recommendations have refrained from any influence on the ECB's actions – and this was understandable in view of the primary mandate at the forefront. Any influence in this respect would not have been accepted by the ECB and, ultimately, probably neither by the European Court of Justice (ECJ). Nevertheless, the situation is different for the secondary mandate, as just explained. Within the framework of its secondary mandate, the ECB is active only in a supportive capacity, but nevertheless in the field of economic policy. Its activities, therefore, are necessarily part of the economic policy in the EU as a whole, to which the concretisation competence of Article 121 (2) TFEU explicitly refers – neither does it differentiate between specific institutions, nor does it explicitly exclude the ECB as a possible addressee of the recommendation. Turned differently, in its recommendation under Article 121 (2) TFEU, the Council can thus also define in more detail and specify the ECB's contribution to economic policy in the EU through its secondary mandate. In terms of content, this recommendation could thus not only specify the secondary mandate, for instance the fight against the climate crisis as an objective to be pursued by the ECB as a matter of priority, but also specify the permissible instruments to which the ECB should have recourse in this context, such as the preference for green bonds as hedging instruments or the preferential purchase of corresponding bonds in the context of new purchase programs.

What consequences would such a concretisation by the Council have for the ECB's actions? First, from this point on, the ECB would be able to refer to the Council's recommendation when reverting to its secondary mandate. Its action in the area of combating the climate crisis would thereby acquire the necessary democratic and political legitimacy, especially since the Council's recommendation is based on conclusions of the European Council, which reaches these unanimously. The political responsibility for the ECB's actions would be assumed by the Council and the European Council, which both would have the possibility to adjust or modify the recommendation at any time if they were dissatisfied with the ECB's behaviour in this regard. Moreover, since it is merely a recommendation that is not legally binding according to Article 288 TFEU (unlike a regulation), the ECB might also deviate from it at any time. Two constellations must be distinguished in this respect. First, the ECB would be obliged to deviate from the Council's recommendation if, and to the extent that, such action would be incompatible with its primary mandate. The recommendation as such, of course, does not change the hierarchy between primary and secondary mandate. Second, it would also be possible for the ECB, at least formally, to concretise the secondary mandate independently, thereby leaving the recommendation completely or partially aside. In this case, however, it would risk that the measures taken would lack the necessary democratic legitimacy, so that either the ECJ or the Federal Constitutional Court could intervene. Overall, this solution would provide the ECB with the necessary democratic legitimacy to make effective use of its secondary mandate, without risking the flexibility it needs to exercise its primary mandate.

## 4 Conclusion

Tackling the climate crisis presents itself as the central challenge of the coming decades. From a legal perspective, the aim will be to show how the individual



institutions – including the ECB – can contribute to this task. In this respect, it is already apparent today that the new types of climate risks must lead to a reinterpretation of the ECB's primary mandate.<sup>52</sup> Climate risks can have an influence on financial and price stability. However, precisely because the ECB has shown itself to be such a powerful institution in the financial and euro crisis, it would be negligent not to at least consider how it might contribute to the general goal of climate neutrality beyond a mere reformulation of its traditional monetary policy.

The often neglected secondary mandate offers a useful starting point. However, in order for this mandate to be effective, it requires sufficient democratic legitimacy.<sup>53</sup> Getting involved in the fight against climate change is highly political, and thus needs to be tied back to the political institutions. The approach proposed, namely to have the mandate and the permissible instruments specified by the (European) Council via Article 121 (2) TFEU, could be one way of ensuring this necessary democratic legitimacy. Inevitably, difficult demarcation problems arise, not only because the primary and secondary mandates overlap in many respects. One might also think of other ways of increasing the level of democratic legitimacy, for example by means of special accountability procedures and by intensifying the monetary dialogue between ECB and European Parliament. What is certain, however, is that the ECB should not be excluded when thinking of possible ways to tackle the climate crisis simply because it might appear too complicated according to current monetary dogma. The task is simply too important to do so.

---

<sup>52</sup> See Smits, R. (2022), "The ECB's Road Ahead", in: Beukers, T., Fromage, D. and Monti, G. (eds.), *The New European Central Bank*, Oxford University Press, Oxford, p. 422.

<sup>53</sup> See also Amtenbrink, F. and Markakis, M. (2022), "The Legitimacy and Accountability of the ECB at the Age of Twenty", in: Beukers, T., Fromage, D. and Monti, G. (eds.), *The New European Central Bank*, Oxford University Press, Oxford, p. 291.

# The constitutional assessment of the ECB's objectives and tasks outside monetary policy

Klaus Tuori\*

## 1 Introduction

The debate concerning the European Central Bank (ECB)'s objectives and tasks that lie outside the strictly defined field of monetary policy mandate has gained interest over the last few years, which could be explained by both supply and demand factors. On the former, the ECB's reach to the euro area economy has increased dramatically since 2015. It has arguably become the most important single factor in the euro area financial markets, which makes it a tempting source for financing. On the demand-side, new societal urgencies have called for a more active participation also from the ECB.

However, the assignment of new tasks and objectives for the ECB, either by its own initiative or by the European Union (EU)'s legislators, is a complex issue. The ECB's constitutional design is unique even among the central banks that generally have a special position in public administration. Unlike other central banks, the ECB is responsible for the money creation of a monetary union; it has a sovereign task without a clear sovereignty. The monopoly right to issue currency provides an enormous potential financial firepower,<sup>54</sup> which explains why the ECB's constitutional mandate was designed very narrowly, but also the lure to assign new tasks to the ECB. With the firepower comes responsibility, as its use – at least following orthodox monetary economics – involves non-linear risks that are borne by the various sections of the society in a very uneven manner. The exceptional independence given to the ECB to carry out its mandate reflects this responsibility that is ultimately measured by the ECB's ability to maintain price stability. These peculiarities underlie all the constitutional assessments of the ECB and its mandate, also with regard to the non-monetary policy tasks and objectives, their definition, controlling and prioritising.

This chapter necessarily starts by looking at the broader starting point for the assessment of the ECB's mandate, where I find three different phases of discussion: the original interpretation of the Treaty-based mandate, the expansion of the monetary policy mandate during the economic and financial crisis (EFC), and most lately the expansion of the tasks of the ECB largely following its asset purchases. This can be used to draw some conclusions in the form of stylised facts concerning the ECB's

---

\* Researcher at the University of Luxembourg, researching the EU economic constitutional model and EU economic constitutional law with a particular focus on the ECB and money.

<sup>54</sup> Buiter, W. (2021), *Central Banks as Fiscal Players - The Drivers of Fiscal and Monetary Policy Space*, Cambridge University Press, Cambridge.

mandate on the basis of an economic-constitutional assessment of the other ECB's tasks and objectives. The specific issues include whether it is possible to prioritise different non-price stability related tasks and objectives. This also requires a few words on the use of the proportionality principle in guiding the ECB. The chapter concludes with some proposals on how to analyse the other tasks and objectives of the ECB going forward. A key finding is that defining the ECB through its role as the central bank rather than through the price stability objective might add legal clarity and even improve legitimacy and accountability.

## 2 Three broad phases of discussion on the ECB's mandate

The discussion of the ECB's mandate is a multifaceted issue that contains both economic and legal perspectives as well as theoretical and practical considerations that all might have validity claims as to the correct interpretation. These various factors have had different weight at the different periods time. Hence, in order not to give excessive weight to topics of the day, it is worth to distinguish three broad phases in the discussion on the ECB's mandate: initialisation phase, borders of monetary policy phase, and finally the borders of the ECB's phase, each of which with relevant information for our topic.

### 2.1 Initial phase - original Treaty interpretation

In the first phase, the aim was to define the ECB as a new EU economic institution and the new economic-constitutional framework for the new central bank. This led to the original mandate of the ECB as it was understood on the basis of the Maastricht Treaty and central bank practice toward the end of the 20<sup>th</sup> century.<sup>55</sup> The public debate was muted, and few major disagreements surfaced concerning the resulting operational mandate of the ECB that followed the narrow central banking model, the content of which is best visible in the original monetary policy strategy of the ECB.<sup>56</sup>

In the original strategy, the concept of ECB's secondary mandate did not exist as such. The ECB Governing Council (GC)'s requirement to support the general economic policies in the Union reflected the "broad need for mutual co-operation and dialogue among policy-makers in an interdependent environment". At the same time, the GC stressed that as a recognition of the "dangers of political interference in monetary policy, the Treaty states that the Eurosystem's actions must be without prejudice to the objective of price stability". The key point was that "the best contribution the single monetary policy can make in this supportive role is to focus unambiguously on

---

<sup>55</sup> The key decision-makers were largely the same as those that had been drafting the monetary policy provisions of the Treaty (and the ECB's Statute), as members of the Committee of Governors. See James, H. (2014), *Making the European Monetary Union*, Princeton University Press as an excellent reconstruction of the role of the EU central bankers in the Maastricht Treaty.

<sup>56</sup> European Monetary Institute (1997), "The Single Monetary Policy in stage three - Elements of the monetary policy strategy of the ESCB", Frankfurt am Main.

maintaining price stability over the medium term and thereby creating the stable environment in which other policies can be most effective.”<sup>57</sup>

Although the ECB did not mention a secondary objective (nor a secondary mandate), it did at times refer to objectives in plural, recognising that the term ‘primary objective’ does lead to assume that there could be other objectives. Among the objectives mentioned in Article 3 ECB’s Statute, the principle of free market economy and free competition gained most attention, and were reflected in the design of the ECB’s operational framework.

Legally, many important smaller decisions and interpretations concerning the mandate of the ECB took place during the preparations for the stage three of the Economic and Monetary Union (EMU). This legal convergence towards the requirements of the EMU was also an entry criteria for the stage three of the EMU.<sup>58</sup> Hence, countless smaller decisions and changes at the national level drew the lines of common monetary policy in relation to national economic policies. For example, practically all setting of interest rates at Member State level was deemed being part of the exclusive competence of the ECB.<sup>59</sup>

In all, the ECB was consistently seen as the policy-maker mainly in the field of monetary policy, also by the academia and the EU polity.<sup>60</sup> The focus was on maintaining price stability, while the ECB’s role in promoting the smooth operation of payment systems was an additional area of competence with a delimitation that it consisted of an oversight function of systems while entities such as banks remained as a national responsibility. Hence, apart from some exceptional cases, the ECB’s mandate of a narrow central bank was not questioned.

## 2.2 Re-defining the borders of common monetary policy

The second phase of defining the mandate of the ECB was caused by the EFC. This time, the mandate of the ECB became the focal point in constitutional discussions through (re-)defining the borders of the euro area monetary policy. Initially, the discussion was mainly economic and political, starting in earnest with the selective purchase of Member State government bonds through the Securities Market Programme (SMP) in May 2010. In this discussion, the mandate of the ECB was challenged for either exceeding the scope of monetary policy and relatedly for violating the ECB-specific constraints of prohibition of public finances (Article 123 Treaty on the Functioning of the European Union (TFEU)). The debate continued with the Outright

---

<sup>57</sup> European Central Bank (1999), “The stability-oriented monetary policy strategy of the Eurosystem”, *Monthly Bulletin*, January.

<sup>58</sup> Ref. convergence reports

<sup>59</sup> For further information, the Annual Reports of the EMI and also the EMI convergence reports are helpful. Additional information could be gained, for example, from the annual reports of the national central banks during the designing phase of the common monetary policy.

<sup>60</sup> Of the early comments, see, Amtenbrink, F. and de Haan, J. (2002), “The European Central Bank: An Independent Specialized Organization of Community Law - A Comment”, *Common Market Law Review*, No 39; Dyson, K. and Featherstone, K. (1999), *The road to Maastricht: negotiating economic and monetary union*, Oxford University Press, Oxford; Elderson, F. (2005), “Legal interpretation within the European System of Central Banks: is there method in ‘t’?”, in European Central Bank, *Legal aspects of the European system of central banks*, Frankfurt am Main, pp. 93-114.

Monetary Transactions (OMT) and also the Public Sector Purchase Programmes (PSPP) that redefined the reach of the ECB's monetary policy well beyond what was envisaged during the first phase.

From the economic perspective, the main issue was to define the ECB's monetary policy exceedingly through the monetary policy transmission mechanism. This meant in reality that the ECB's monetary policy mandate was defined to include measures to contradict developments in the euro area financial markets, particularly government bond markets, to the extent that they were seen to harm the passthrough of monetary policy impulses. Arguably, the measures to fight financial instability and to ensure public sector financing on one hand, and to restore monetary policy transmission on the other were largely inseparable.

The formal legal debate concerning the borders of monetary policy came with a lag. Paradoxically and even unfortunately, the legal borders of common monetary policy were initially drawn from the outside, by defining the content of the Member State fiscal policy in the *Pringle* case.<sup>61</sup> The broader merits and caveats of the *Pringle* case are outside this contribution, but its 'original sin' also for the ECB's broader mandate issue was the Court of Justice of the European Union (CJEU)'s method of defining monetary policy mainly through its objective and additionally through its instruments. Arguably, more substantive definitions are available that could have focused more on the 'monetary' part of the policy and also central banking nature of the ECB. While the CJEU's choice followed its earlier judgments in more technical fields, the applicability of the method for central banking and monetary policy created some confusion. As prices are everywhere and everything affects prices, the mere objective of price stability does not really help in defining the borders of the central banks legal mandate. The ECB also remains the sole exception among central banks in this regard.

The ECB specific case-law followed in the form of *Gauweiler* and *Weiss* cases,<sup>62</sup> which continued to define monetary policy through its price stability objective. They underlined two relevant features concerning the ECB's mandate. First, the fundamental disagreement between the German Constitutional Court (FCC) and the CJEU on defining the borders of the ECB's monetary policy perhaps revealed the vague nature of price stability objective as a legal concept. Second, the borderlines of monetary policy became discussed under the principle of proportionality, not under the concept of conferral. Baquero Cruz has put the blame largely on the FCC's for the use of proportionality in defining monetary policy that raises questions from the perspective of the logic of the EU legal order.<sup>63</sup> However, the main problem seems to be that monetary policy as an exclusive EU competence has been defined in the CJEU's case-law in terms that do not provide any clear or measurable limits to this competence. If anything can be claimed to be monetary policy, it is only the proportionality of these measures to achieve their objectives that is left to protect the principle of conferral.

---

<sup>61</sup> Judgment of 27 November 2012, *Thomas Pringle v Government of Ireland and Others*, Case C-370/12, ECLI:EU:C:2012:756.

<sup>62</sup> Judgment of 16 June 2015, *Gauweiler and Others*, Case C-62/14, ECLI:EU:C:2015:400; judgment of 11 December 2018, *Weiss and Others*, Case C-493/17, ECLI:EU:C:2018:1000.

<sup>63</sup> Baquero Cruz, J. (2022), "Karlsruhe and its Discontents", EUI LAW Working Paper 2022/10.

On the legal and constitutional side, this second phase was extremely important, as it gave birth to EMU law or EU crisis law with its landmark cases, institutional measures and academic activity. The main legal concepts and tools for assessing macroeconomic issues at the EU context were developed, including the definition of competences through their objectives also in macroeconomic fields, the increased constitutional role of proportionality, and also considering monetary policy similar to some technical fields of EU agencies, where the expert organisation is given very broad discretion. At the same time, this legal practice was crisis-driven and as it stretched the boundaries of monetary policy, it also stretched boundaries of legal interpretation. Hence, it might have left some room for normalisation and allow for more substantive assessment of the policy measures.

## 2.3 Re-defining the border of the ECB

The third phase is partly parallel with the second one. It consists of the formal and also practical expansion of the tasks, aims and objectives of the ECB beyond strictly defined monetary policy. The formal expansion started off with tasks mainly related to financial stability with the establishment of the European Systemic Risk Board in 2010, when the ECB was for the first time conferred specific tasks related to credit institutions on the basis of Article 127(6) TFEU.<sup>64</sup> Four years later, the scope of this specific task was stretched to the limit, when the main responsibility for the euro area banking supervision (Single Supervisory Mechanism) was assigned to the ECB.<sup>65</sup> These tasks were formally outside the scope of monetary policy, although many central banks had similar functions.

Arguably the largest expansion of the ECB's economic reach in the euro area came within the tasks and aims that were formally conducted as monetary policy. It started with EFC, when the concept of repairing or correcting of monetary policy transmission mechanism of the euro area was introduced to rationalise measures that in other countries have often been rationalised by financial stability considerations.<sup>66</sup> Indeed, the roles of many major central banks increased dramatically since the eruption of the EFC, and the ECB was initially on the more hesitant side due to the constitutional considerations. However, the main expansion of the ECB's reach to the economy took place with initially a pure monetary policy measure, namely quantitative easing in the form of purchase of government bonds. First, the PSPP gradually expanded, and in 2020 the Pandemic Emergency Purchase Programme (PEPP) intensified the purchases. Indeed, the PEPP together with various programmes to ensure funding for the euro area banks expanded the ECB's (Eurosystem central banks) balance sheet almost beyond comprehension and more than was the case other major central banks.

---

<sup>64</sup> Council Regulation (EU) No 1096/2010 of 17 November 2010 conferring specific tasks upon the European Central Bank concerning the functioning of the European Systemic Risk Board (OJ L 331, 15.12.2010, p. 162).

<sup>65</sup> Council Regulation (EU) No 1024/2013 of 15 October 2013 conferring specific tasks on the European Central Bank concerning policies relating to the prudential supervision of credit institutions, OJ L 287, 29.10.2013.

<sup>66</sup> Tuori, K (2022), *The European Central Bank and the European Macroeconomic Constitution: From Ensuring Stability to Fighting Crises*, Cambridge University Press, Cambridge.

Indeed, the combined Eurosystem balance sheet peaked at 70 % of the euro area Gross Domestic Product (GDP) in mid-2022.

It is this massive increase in the balance sheet of the ECB that has increased its impact on the economy and society at large. By many accounts, the ECB is currently the main actor in the euro area capital markets, and its measures are having financial stability and public finance consequences well beyond the narrow central bank model. In practice, it is hardly possible to enumerate and assess all the direct and indirect effects of the ECB measures, and their intensities and probabilities. Such an influence, be it intentional or unintentional, direct or indirect, or considered unavoidable consequences or even collateral damage, raises new possibilities as well as new risks. One consequence is that, as this setting is viewed a more sustained state of affairs, it has invited interest to use this ECB's reach in the economy as a means to promote other desirable social causes. In particular, asset purchases and also directed lending to banks can be added with other criteria in addition to those that stem from narrow price stability considerations.

The large balance sheet thus has consequences for the mandate of the ECB. This concerns both to the ECB's direct asset purchases, including the selection and exclusion of purchased assets, but also to the ECB's lending to banks (particularly the Targeted longer-term refinancing operations (T-LTROs)). The latter has become more targeted according to the type of lending but also to the eligible collateral. In practice, by and large the same measures could be motivated by monetary policy arguments, by other tasks and objectives or by intentional or unintentional indirect effects.

Apart from the actual balance sheet expansion, the ECB has itself invited discussions on its broader impact on the society. The lengthy process of the strategy review that ended in mid-2021 discussed explicitly the impact of monetary policy to various areas.<sup>67</sup> As an even more drastic step, the ECB announced in its climate agenda in 2022 that the climate change mitigation was an explicit goal for which the ECB plays its "part in supporting general economic policies".<sup>68</sup> In the same document, the ECB outlines somewhat how this is put in practice. With this move, the ECB has opened the door for new and more explicit uses of its objective of supporting general economic policies.

Finally, and in addition to the new interpretations of the ECB's Treaty-based mandate, it could be argued that new issues outside the scope of the Maastricht Treaty have surfaced. The main two new issues are climate change and digitalisation that are incidentally also the main fields mentioned in the Next Generation EU (NGEU)<sup>69</sup>. Due to their nature, they were not considered in any substantial weight during the drafting of the Maastricht Treaty that led to the narrow central bank model for the ECB. To the extent that these factors can be seen as major factors shaping the economic and

---

<sup>67</sup> Ioannidis, M., Hlásková Murphy, S. and Zilioli, C. (2021), "The mandate of the ECB: Legal considerations in the ECB's monetary policy strategy review", *Occasional Papers Series*, No 276, ECB, Frankfurt am Main, September; European Central Bank, "Strategy review", available at <https://www.ecb.europa.eu/home/search/review/html/index.en.html>.

<sup>68</sup> ECB climate agenda 2022 (4 July 2022), [https://www.ecb.europa.eu/press/pr/date/2022/html/ecb.pr220704\\_annex-cb39c2dcbb.en.pdf](https://www.ecb.europa.eu/press/pr/date/2022/html/ecb.pr220704_annex-cb39c2dcbb.en.pdf)

<sup>69</sup> See, [https://next-generation-eu.europa.eu/index\\_en](https://next-generation-eu.europa.eu/index_en) for further information.

financial landscape going forward, they might get some more interpretative leeway when the Treaty provisions are considered.

### 3 The Treaty-basis and interpretation of the ECB's mandate (objectives and tasks)

The actual evolution of the ECB's mandate showed unsettled and even expanding characteristics. This should be complemented with relevant legal and economic factors before turning to any conclusions.

#### 3.1 Textual basis of the mandate

The ECB is an EU institution that gets its constitutional framework and particularly its mandate from the TFEU. More detailed and also practical issues are addressed with the ECB's Statute and hence also part of EU primary law. As discussed earlier, the CJEU has provided guidance on the definition of the monetary policy mandate. In addition, EU secondary legislation has provided further specifications and authoritative interpretations.<sup>70</sup>

The starting point for the assessment of the ECB's mandate, including its objectives and tasks, is often omitted: the name of the institution. It is the European Central Bank; a bank that is at the centre of the banking system and mainly functioning through the broader banking system. Central banking is a peculiar part of public administration that has a relatively long history, and a fairly well-defined set of activities at any given time. The Maastricht Treaty refrained from defining a central bank as such, but it did require in Article 283(2) TFEU that the "members of the Executive Board shall be appointed by the European Council [...] from among persons of recognised standing and professional experience in monetary or banking matters".

For the ECB's mandate, the key Article is 127 TFEU that provides the objectives and task of the ECB as well as additional clarifications for the position of the E(S)CB in relation to some areas that are close to central banking, such as financial stability and prudential supervision. The objectives mentioned in Article 127(1) TFEU (and repeated under heading objectives in Article 2 ECB's Statute) include:

1. the primary objective shall be to maintain price stability;
2. it shall support the general economic policies in the Union with a view to contributing to the achievement of the objectives of the Union (Article 3 TEU);
3. it shall act in accordance with the principle of an open market economy with free competition, favouring an efficient allocation of resources; and

---

<sup>70</sup> For a constitutional summary, see, Tuori, K. (2020), "Monetary Policy (objectives and instruments)" in *The EU Law of Economic and Monetary Union*, Oxford University Press, Oxford, pp. 615-698.



4. it shall act in compliance with the principles set out in Article 119 TFEU (stable prices, sound public finances and monetary conditions and a sustainable balance of payments).

The ECB objectives have a clear hierarchy, where the first is its main objective and its *raison d'être*. The other objectives are providing a guiding framework of how the main objective is to be carried out. They are general and linked to other objectives and guiding principles. Also, the ECB is given the exclusive right to authorise the issue of euro banknotes that “shall be the only such notes to have the status of legal tender within the Union” (Article 128 TFEU).

Similarly, Article 127(2) TFEU (and Article 3 ECB's Statute) discuss the basic tasks of the ECB. The first task is to define and implement the monetary policy of the Union. This forms the core of the ECB's mandate together with the price stability objective and Chapter IV ECB's Statute with monetary functions and operations of the E(S)CB. The second and third tasks established the ECB as the guardian of exchange operations and the official foreign reserves of the Member States, while the ultimate responsibility over exchange-rate arrangements remained in the political sphere. The final basic task is to promote the smooth operation of payment systems that jointly includes a task and an objective. A further task to “contribute to the smooth conduct of policies pursued by the competent authorities relating to the prudential supervision of credit institutions and the stability of the financial system” is still included under the ‘Tasks’ Article. In contrast, the possibility also mentioned in Article 127(6) TFEU to perform specific tasks concerning policies relating to the prudential supervision was separated to a later Chapter V, which highlights its distance from monetary policy related functions.

The Treaty basis for the ECB's mandate has remained fundamentally the same from the start. The strictly monetary policy part of the ECB's mandate still contains a typical list of activities for central banks. The main legal changes have related to special tasks that have been assigned to the ECB with regard to financial stability and prudential supervision, and indirectly via the new Article 136(3) TFEU. Therefore, it is the role of central banks in general and the role of the ECB in the EU economic policy framework that have changed during the nearly quarter of a century of common monetary policy, which might have changed the interpretation of the ECB's mandate.

### 3.2 The interpretation of the ECB's other objectives

Accordingly, the interpretation the ECB's mandate has a mostly unchanged textual basis on one side, and the three phases of changes in the actual mandate on the other. Similarly, while the original Maastricht model could still be constructed as a coherent economic-constitutional architecture with a longer-term stability and viability at its heart, it has also been claimed incomplete or failed by many political actors and scholars alike. This tension is aggravated by the lack of consensus on what the alternative model going forward could be or how it could be made consistent with the Treaty provisions. The approach chosen here could be labelled a broad economic-constitutional assessment that combines the textual, contextual or historical

interpretations of the relevant provisions with their broader economic context. The constitutional perspective demands both coherence and also a longer perspective that sees beyond current, even pressing problems.

The objective to support general economic policies has been most widely discussed lately, not least because the ECB has made its first concrete reference to it. Starting with a literal reading, it demands that the ECB should support (only) general economic policies in the Union that aim at EU's mentioned objectives, and the ECB should aim at those values primarily through supporting general economic policies. As could be recalled, the initial reading of this support objective was that it basically required the ECB be mindful of the objectives of the EU and not to isolate itself, while also being mindful of not allowing political pressures to influence its monetary policy. It was a requirement to engage in co-operation and dialogue, which was pursued, for example, by reciprocal visits of the heads of ECB Governing Council and the Economic and Financial Affairs (ECOFIN) Council.

The main test for the support function came with the EFC. The ECB measures were closely linked to other efforts at the EU level to solve pressing problems, either through timing as with the SMP just after the Council meeting or through formal links such as with the OMT that required a European Stability Mechanism (ESM) programme.<sup>71</sup> Other programmes had similar links, of which the PEPP was perhaps the most expansive by providing a funding backstop for the governments. However, in all of these cases the ECB chose to argue on the basis of price stability and monetary policy transmission mechanism arguments, not the support of the general economic policies. The conclusion could be that the support of the general economic policies has been analysed within monetary policy considerations.

In contrast, the ECB's objective to act in accordance with the principle of an open market economy with free competition was discussed relatively actively when the ECB operational framework was designed and its choices were rationalised. However, since the EFC the references to the objective have been rare, although many ECB measures have affected the open economy and free competition, and even questioned them as efficient solutions to allocative decisions. The selective bond purchases and also the PEPP were rationalised by the malfunctioning of the markets or by the risks thereof. Similarly, the euro area interbank markets have at times been replaced by the operational framework of the ECB, as demonstrated by the growth of TARGET2 imbalances. The interpretations could be that this objective mainly refers to the ECB's own measures and it is therefore discussed and justified by broader monetary policy considerations.

Concerning the objective to act in compliance with the principles set out in Article 119 TFEU that include stable prices, sound public finances and monetary conditions as well as sustainable balance of payments, the ECB has rarely referred directly to it, although the said principles are regularly discussed, for example, in the GC monetary policy decisions. Naturally, some questions might be asked about acting in compliance with sound public finances, when the ECB measures aim at lowering the interest rates

---

<sup>71</sup> European Central Bank (2012), "Technical features of Outright Monetary Transactions", *Press Release*, 6 September, available at [https://www.ecb.europa.eu/press/pr/date/2012/html/pr120906\\_1.en.html](https://www.ecb.europa.eu/press/pr/date/2012/html/pr120906_1.en.html).

on government bonds or has led it to become the largest holder of government bonds in the euro area. Again, the internal analysis of monetary policy measures most likely has involved elaborations on this objective and perhaps affected on the choices between instruments.

The tasks of the ECB form the other part of the mandate, where the tasks of Article 127 TFEU are directly linked to the conduct of monetary policy and acting as the central bank of the euro area. Only the promotion of smooth operation of payment systems forms partly a separate task to monetary policy. However, even there the interpretation of the ECB has stressed the link between payment systems and monetary policy, and incidentally the two areas use the same collateral through TARGET2 system. The main issue has been whether the promoting task suffices to create a mandate for running its own payment systems. This has been a topic more broadly in central banking mainly in the context of the Bank for International Settlements (BIS). The conclusion for the ECB has been that it is, with some safeguards to protect competition, mandated to run a payment system for large (monetary policy related) payments while acting as the overseer of other, potentially competing payment systems.

Concerning the non-monetary policy tasks, supporting of prudential supervision and financial stability are of particular interest. The task assumes competent authorities as the policy-makers that can be supported, which was initially defined by the ECB's facilitation of co-operation between the competent authorities through various forums, including the ECB Banking Supervision Committee, and producing relevant research. However, the complexities increased in 2014, when the ECB became a competent authority in the area of prudential supervision that it is then supporting!

The interesting finding concerning the interpretation of the ECB's mandate is that not much has changed, even when the actual reach of the ECB is hardly the same as in 1999. Clearly, the scholarly discussion on the legal practice concerning EMU's mandate has become, if possible, even more polarised and even somewhat emotional. This might reflect the importance of the topic, but also the fact that many substantive and mainly macroeconomic issues involved have deeper roots in societal beliefs and values. Underlying economic and political beliefs then become framed as legal opinions based on the (only) interpretations of Treaty articles.

Lately, the main issue of the other objectives has circled around the topic of climate change and green monetary policy more generally. In particular, those observers who advocate the perception that the ECB's actions to promote the fight against climate change should be seen as supporting the general economic policies, have placed emphasis on the word 'shall' as an obligation to support. However, apart from stating the obvious that 'shall' is different than 'may', it does not in itself bring a clear obligation to anything specific. Clearly, if the support task was perceived to include a procedure through which the ECB is obligated to support general economic policies, this would have been included. Similarly, if the ECB could be given some special tasks, this would also have been included in the Treaty provisions as was the case with prudential supervision. Against this background, we can turn next to what could be seen as a suggested reading of the ECB's mandate with regard to its other tasks and objectives.

## 4 Stylised facts on defining other tasks and objectives of the ECB

The current discussion on the ECB's tasks and objectives reflects the broader polarisation of the legal and constitutional debate on the EMU that has remained an undercurrent among EU legal and also economic scholars. On one side, many observers still understand the Treaty construction as it was generally perceived during the first phase, namely that the other tasks and even objectives of the ECB should be seen as axillary to its monetary policy function, including payment system functions and supporting competent authorities in maintaining financial stability. The support of the general economic policies is perceived mainly as a co-operation through sharing information and voluntary co-ordination of policies. The idea of the ECB as a policy-maker in other fields would be inconceivable. This perspective was also early on criticised for being too restrictive and even monetaristic, where the critics often pointed to the broader democratic deficiencies in the EMU constitutional architecture. This initially un influential but more expansive perspective has gained traction of late, as particularly the environmental sustainability has demanded that all the policy-makers to engage in the fight against climate change.<sup>72</sup> The constitutional question remains how to balance these perspectives without sacrificing the constitutional values embedded in the EMU constitutional model.

### 4.1 The ECB is the central bank of the euro area

As discussed earlier, the ECB could more explicitly be seen as the central bank of the euro area, also in constitutional terms. This implies that the definition of the area conferred to the ECB would be interpreted primarily through the central banking function, not through the objective of price stability. Such a more substantive and functional definition could allow both better justifications and also following the developments in the central banking function more generally.

A more substantive discussion on the ECB's functions could address the other objectives and tasks of the ECB as functions of a bank at the centre of the banking system. While the practical difference to the present situation might be limited, the means of argumentation would change and hopefully become more reflective of reality. A key issue would be to discuss whether a measure is part of central banking and hence a part of the conferral. This might avoid discussing the proportionality of monetary policy measures or framing measures related to financial stability through the monetary policy transmission mechanism arguments.

---

<sup>72</sup> See, for example, Solana, J. (2019), "The power of the Eurosystem to promote environmental protection", 30 *European Business Law Review*; Fischer, Y. (2019), "Global warming: Does the ECB mandate legally authorise a 'green monetary policy'?" in Beekhoven et al (Eds.), *Sustainability and Financial Markets*, Wolters Kluwer; Smits, F. (2021) 'Elaborating a climate change-friendly legal perspective for the ECB', available at SSRN; van Tilburg, A. and Simic, R. (2021), "Legally green: Climate change and the ECB mandate", Sustainable Finance Lab Policy Paper; Grunewald, S. (2021), "Climate-related risks: Is the macroprudential framework fit for purpose?", BuBerworths *Journal of International Banking and Financial Law*, Vol. 36(11), pp. 743-745; and Grunewald, S. and van 't Klooster, J. (2023), "New strategy, new accountability: The European Central Bank and the European Parliament after the strategy review", European Banking Institute Working Paper Series no. 139.

## 4.2 The ECB is the policy-maker (only) in monetary policy area

The constitutional framing of the ECB as the central bank would not change the basic starting point that the ECB is the EU policy-maker only in the area of monetary policy and to a more limited extent payment system overseer. This is underlined by the fact that the people in the ECB decision-making bodies are selected among experts in monetary and banking matters. Constitutionally monetary policy is the area where the ECB is actively formulating the content of EU policy, and it is also the only area that is covered by the ECB's accountability mechanisms that do not fair well with explicit value judgements.<sup>73</sup> Indeed, the ultimate accountability mechanism is through the provision of price stability that is a measurable obligation directly towards euro area citizens that can be supported by transparency (as well as by care and reason)<sup>74</sup>.

The hesitation to assign many tasks and objectives to monetary policy-makers has been a key theme during the era of the so-called fiat currencies. For one, the monopoly right to issue legal tender remains the ultimate origin of the central bank power. It is a source of substantial income, but also a potential source of major economic and social unrest, which is aggravated by the fact that the initial cost of issuing excessive money might be small while the ultimate cost can be very high. An additional reason for limiting the tasks of central banks could be avoiding major concentration of power. Both of these reasons could be valid for the ECB as well, and even enforced by its large degree of independence.

## 4.3 Monetary policy is predominantly cyclical policy that fits poorly with structural policies

The conduct of monetary policy is mainly cyclical rather than structural policy. By keeping inflation expectations well-anchored, the central bank can contribute to the longer-term stability and success of the euro area, but pro-active structural policies are for other policy-makers. The bias on cyclical policies has the repercussion that the ECB's participation in other policies might need to react to monetary policy needs, and at worst become destabilising factor to those secondary objectives it aimed to support.

Naturally, the operational framework of the ECB can have a market-building impact on some areas of financial markets, by creating objective information and classification mechanisms for the market place and its participants. However, the ECB asset purchases could be particularly problematic from this perspective, because in a neutral state the ECB holdings could be zero. Sustained very large asset holdings contain a risk that the ECB becomes tied up in financing some segments of financial markets. The creation of the Transmission Protection Instrument<sup>75</sup> could be seen as a recognition that the PSPP/PEPP asset purchases have potentially become critical for

---

<sup>73</sup> Fromage, D. et al (2019), "ECB independence and accountability today: Towards a (necessary) redefinition?", *Maastricht Journal of European and Comparative Law* 26 (1), 3-16.

<sup>74</sup> Mendes, J. (2023), "Law and Discretion in Monetary Policy and in the Banking Union: Complexity Between High Politics and Administration", *Common Market Law Review*, forthcoming.

<sup>75</sup> <https://www.ecb.europa.eu/press/pr/date/2022/html/ecb.pr220721~973e6e7273.en.html>

some market segments, whereby cyclical reduction on holdings need to be compensated by other means.

It could be noted that the structural policies with regard to financial markets have been covered in the EU economic-constitutional architecture. The longer-term financing, while being primary a private sector and secondarily a Member State responsibility, has the European Investment Bank as the responsible EU institution. In addition, the ESM has extensive fire-power for the coordinated Member State actions to combat financial instabilities.

#### 4.4 The objective to support of general economic policies remains a non-isolation and sincere co-operation clause

Seen in the context of the logic of the Treaty, textually and also compared to other central banks, the objective is most naturally an EU equivalent for the central bank obligation to pay attention to growth and employment. However, even if the ECOFIN Council made a unanimous decision that the ECB would need to purchase some bonds or lower interest rates, this decision would be nothing more than a wish from their side, and as legally binding as would be the ECB urging that some or all Member States increase or reduce their public deficits. Similarly, the support for the general economic policies would seem to exclude any more specific programmes or aims.

#### 4.5 The proportionality principle is a blunt (or wrong) instrument to control for the increased economic and societal reach of the ECB

The monetary policy in the euro area, as in many other countries, is currently a larger societal force than ever. Its direct and indirect effects are manifold, turning monetary policy into a constitutional issue among other things. However, the EU solution to employ proportionality principle might not have solved the underlying problem. It suffices to read the CJEU and FCC proportionality analysis, or to take the FCC criticism concerning the CJEU *Weiss* judgment seriously, to conclude that proportionality assessment is hardly the most illuminating means to discuss conferral of some key elements of economic policy to an independent EU institution. It could be added that no other country seems to use either price stability objective to define monetary policy function nor proportionality assessment to delimit the conduct of monetary policy.

However, the proportionality principle might have a role to play with regard to other tasks and objectives of the ECB, if the broader area of conferral was properly discussed. It could be appropriate to check and also justify whether a given measure is appropriate for promoting the smooth operation of payment systems, such as running its own large-scale payment system. In that regard, the proportionality check could include the justification that such a payment system also facilitates the conduct of monetary policy. Similar assessments could be made with regard to the acting in accordance with free markets and open economy. The support for the general economic policies is more problematic for the proportionality assessment though, as

procedures for defining the concrete objective are lacking and even the counterparts and policies are unprecise. Analysing the proportionality of ECB measures against such an uncertainty risks becomes arbitrary.

A further proportionality test for the ECB could take place in relation to Member State and other EU institutions, namely whether the ECB is the most appropriate institution to take the action that has a link to its other tasks and objectives. While such an assessment holds a major constitutional value, it could be more flexibly conducted by analysing the conferral of central banking function to the ECB.

The critical issue, either in analysis of conferral (central banking) or proportionality, remains the obligation for the ECB give justifications for its measures and to enhance actual transparency of its operations.

#### 4.6 Article 11 TFEU obliges the ECB as an EU institution to take environmental consideration into account

The debate on using Article 11 TFEU to impose concrete obligations for the EU institutions to fight the climate change or loss of biodiversity is gaining pace. Up to this point, the Article has had a relatively minor impact, but arguably it has potential for a much wider use. In the case of the ECB, the application should be relatively straightforward. It does not make the ECB a policy-maker in the field nor can it be used to impose specific obligations to the ECB, but it would seem to oblige the ECB act accordingly while it is conducting its tasks and aiming at its objectives.

The main difficulties with regard to Article 11 TFEU arise, when it conflicts with some specific tasks or objectives. For example, while it would seem to be straightforward that the ECB should adjust its operational framework to acknowledge environmental protection such as with acceptable collateral, the conflict with the objective of free market and efficient allocation of resources would need to be addressed. In that specific case it should be possible by assuming that an efficient allocation includes features that are omitted from current market-based allocation (negative externalities). The critical element would be to give proper justifications.

#### 4.7 The priorities within the ECB's other objectives and tasks

The open and relatively vague nature of the ECB's other objectives and tasks leaves it open, how the various tasks and objectives should be prioritised. The simple answer would be to derive the priorities, as it has largely been the case in practice, from the functions of the central bank and monetary policy. To the extent that these other objectives and tasks are mainly by-products of the conduct of monetary policy, a key criterion is not harming or risking thereof the conduct of monetary policy either at present or from a forward-looking perspective: not to tie hands of monetary policy now or in a potential future scenario.

The lack of primary law guidance for prioritising other objectives and tasks is a further argument for caution in adding new tasks and objectives. The ECB was not assigned an active process of selecting various secondary objectives, as this would have been stipulated differently also in its Statute.

## 5 Conclusions – how to control the ECB with other objectives and tasks

The ECB is the central bank of the euro area with the outmost responsibility in maintaining the purchase power of the euro, and thereby providing the euro area with stability and long planning horizons. As a central bank, the ECB operates through the banking sector, at its centre, and ensures its functioning. In times of crisis, its functions might include the lender of last resort to banks. The ECB also runs a payment system of its own while also oversees other payment systems from a stability and efficiency perspectives. This all forms a typical set of tasks for a central bank that is demanding in its own right, but it is made extremely difficult by the heterogeneous economy and experimental nature of the euro.

The ECB as any other central bank is directly affected by any major financial instability, most prominently banking crisis. Therefore, it is tasked to contribute to financial stability, but in ways that are left unspecified due to potential moral hazard consequences, but also simply for the lack of information beforehand. As for the other tasks and objectives, the difficulty of the tasks at hand would advise in some caution even before discussing the constitutional issues involved.

The ECB as an extremely independent institution with broad and at places unspecified nature of the tasks and objectives, makes an efficient legal control a persistent constitutional concern. I claimed that for the judicial control, the model chosen by the CJEU that relies on teleological interpretation of price stability objective added with a proportionality assessment is problematic, and it might have led monetary policy transmission to become the main justification for most measures outside the sphere of traditional monetary policy. I would suggest to start from what was being conferred when the ECB became the central of the euro area. While this might not lead to any major changes as to the legal control, it might enhance the control through transparency and giving justifications (care and reason), where the main addressees should be the public and the European Parliament, in this order. Finally, it could be remembered that the main accountability of the ECB is still to the people of the euro area to provide them a currency that holds its purchasing power. Failing on that one could not be compensated with success in any other task or objective.





## Part III

# Incorporation of environmental considerations in the supervision of prudential risks

# What is special about climate-related and environmental risks?

Isabel Schnabel\*

This year has been a record year in many respects. July was the world's hottest ever month, seeing the hottest day ever recorded, while ocean temperatures hit all-time highs. We have experienced heatwaves, droughts, floods, gigantic hail and record low levels of sea ice formation in Antarctica. Climate scientists attribute these records to human-made climate change, exacerbated by the arrival of El Niño.

Not only do these events cause extensive damage to the environment and result in enormous human suffering, but they also adversely impact the macroeconomy, giving rise to significant financial risks.<sup>76</sup>

Dealing with financial risks is the core task of prudential supervision.

Climate-related and environmental risks (C&E risks) are now an important focal point for supervisors.<sup>77</sup> The topic of today's panel discussion – the legal aspects of the incorporation of environmental risks in prudential supervision – could therefore not be more apt or timely.

I am thrilled to be chairing an all-female panel on this important topic with three distinguished speakers, each of whom I will introduce before they speak.

In my short introductory remarks, I would like to explain why C&E risks warrant special supervisory attention from an economic perspective.

There are three main reasons. First, their size, global dimension and non-linearity, which imply large downside tail risks. Second, the irreversible nature of climate change and environmental degradation, and the corresponding time criticality for taking action. And third, the lack of knowledge and data on these risks.

## 1 Size, global dimension and non-linearity

The sheer size of C&E risks justifies giving them special attention. Climate change constitutes an existential threat, implying large downside tail risks.

According to the Network of Central Banks and Supervisors for Greening the Financial System (NGFS), up to 13% of global GDP would be at risk by the end of the century,

---

<sup>76</sup> According to "back of the envelope" calculations performed (see Allianz (2023), "Global boiling: Heatwave may have cost 0.6pp of GDP", 4 August), the recent heatwave may have caused losses of around 0.6 per cent of GDP in the United States, southern Europe and China in 2023.

<sup>77</sup> See Elderson, F. (2021), "The role of supervisors and central banks in the climate crisis", keynote speech at the 31st Lisbon meeting between the central banks of Portuguese-speaking countries, 19 October.

even before accounting for the potential consequences of severe weather events, sea-level rise and wider societal impacts from migration or conflict.<sup>78</sup>

Physical climate risks tend to be correlated globally, as evidenced by today's simultaneous occurrence of extreme weather events, limiting the scope for diversification and creating systemic risks for the financial sector. The economic consequences of physical climate risks could be mitigated by closing the large climate insurance protection gap. In the EU, only a quarter of losses caused by climate-related catastrophes are insured, giving rise to additional risks to the macroeconomy, financial stability and public finances.<sup>79</sup> At the same time, financial sector risks are not confined to physical climate risks; the sector is also exposed to transition risks emanating from changes in policies around the globe in response to climate change.<sup>80</sup>

Lastly, the existence of tipping points may give rise to strong non-linearities. Small changes can have much larger effects than observed historically, making predictions highly uncertain.

## 2 Irreversibility and time criticality

A second distinct feature of C&E risks is that if they materialise, the effects are often irreversible. Therefore, taking action is time critical to slow down global warming and the degradation of the environment.

An orderly climate transition is more likely if decisive action is taken at an early stage. In an orderly transition, a sudden repricing of assets can be avoided and financial intermediaries are able to gradually rebalance their investment portfolios and build up buffers that can absorb potential future losses.<sup>81</sup>

Moreover, in contrast to other risks, C&E risks have an important feedback mechanism, which accentuates time criticality. Not only does climate change affect the risks on financial intermediaries' balance sheets, but the financing of climate or environmentally unfriendly activities also amplifies C&E risks, creating externalities.

---

<sup>78</sup> NGFS (2021), "Second vintage of climate scenarios for forward looking climate risks assessment", 6 July.

<sup>79</sup> For example, if losses are not covered by insurance, the speed at which households and firms can resume their activities is reduced, slowing economic recovery. Additionally, the financial position of governments may be weakened if they need to provide relief to cover uninsured losses. See ECB (2023), "Policy options to reduce the climate insurance protection gap", *Discussion Paper*, ECB, April. See also Rousová, L., Giuzio, M., Kapadia, S., Kumar, H., Mazzotta, L., Parker, M. and Zafeiris, D. (2021), "Climate change, catastrophes and the macroeconomic benefits of insurance", *Financial Stability Report*, EIOPA, April.

<sup>80</sup> Empirical estimates suggest that financial institutions' exposures to climate transition risk are meaningful. See Berner, R., Engle, R. and Jung, H. (2021), "CRISK: Measuring the Climate Risk Exposure of the Financial System", *Staff Reports*, No 977, Federal Reserve Bank of New York, September.

<sup>81</sup> Breckenfelder, J., Maćkowiak, B., Marqués-Ibáñez, D., Olovsson, C., Popov, A., Porcellacchia, D. and Schepens, G. (2023), "The climate and the economy," *Working Paper Series*, No 2793, ECB, March. Batten, S., Sowerbutts, R. and Tanaka, M. (2016), "Let's talk about the weather: the impact of climate change on central banks," *Working Paper Series*, No 603, Bank of England, May.

### 3 Lack of knowledge and data

A third important feature of C&E risks is that the data available and the knowledge we have about them remain limited. We know that climate change and biodiversity loss are already unfolding rapidly but we still lack knowledge about their precise timing and potential tipping points. This means that we must work with scenarios with an unknown probability of occurrence.

Economic models of climate change are typically calibrated on historical data, which means they have difficulties in accounting for non-linear dynamics that have never been observed. They may therefore underestimate the economic fallout. The use of scenarios, as done in macroeconomic climate stress tests, provides a useful way forward. But such scenarios may need to be enriched by socioeconomic factors, such as the risk of violent conflict or mass migration.<sup>82</sup>

Even for known risks, the data are limited. Private and official data providers are working intensively to close the data gaps. To make progress on this front, there is an urgent need for further disclosure initiatives based on the double materiality principle.<sup>83</sup>

In view of the existing data and knowledge gaps, it is very likely that climate-related and environmental risks are currently underpriced. Some risks may not be priced at all, as confirmed by recent research.<sup>84</sup> Rating agencies have only just started to incorporate climate risk into their models.

According to our bottom-up climate stress test, most banks under European banking supervision insufficiently consider climate-related risks in their credit assessments.<sup>85</sup> At the same time, various initiatives on the supervisory front show that banks are making progress in their management of C&E risks, although the trend is not uniform and laggards remain in all areas.<sup>86</sup>

Market mispricing of C&E risks can only be mitigated if more information on those risks becomes available, especially via comprehensive disclosures. In this respect, we still have a long way to go.

---

<sup>82</sup> See Basel Committee on Banking Supervision (2021), "Climate-related risk drivers and their transmission channels", April, for an overview of the macro- and microeconomic transmission channels through which the banking system is exposed to climate change.

<sup>83</sup> For supervisory expectations, including in relation to disclosure, see ECB (2020), Guide on climate-related and environmental risks, November.

<sup>84</sup> For example, it was shown for the United States that physical risks, other than heat stress, are not priced. See Acharya, Viral V., Johnson, T., Sundaresan, S. and Tomunen, T. (2022), "Is Physical Climate Risk Priced? Evidence from Regional Variation in Exposure to Heat Stress", *Working Paper*, No 30445, National Bureau of Economic Research, September.

<sup>85</sup> See ECB (2022), 2022 climate risk stress test, July.

<sup>86</sup> See Elderson, F. (2023), "Climate-related and environmental risks – a vital part of the ECB's supervisory agenda to keep banks safe and sound", introductory remarks at the panel on green finance policy and the role of Europe organized by the Federal Working Group Europe of the German Greens, 23 June; and Jochnick, K. (2022), Climate risks for banks – the supervisory perspective, ECB, September.

To conclude, climate-related and environmental risks warrant special attention owing to their size, global dimension and non-linearity, the irreversible nature of the damage they can cause, the resulting time criticality of action, as well as knowledge and data gaps.

# Environmental protection and prudential risk supervision: legal reflections

Suzanne Kingston\*

“The transition to a carbon-neutral economy provides opportunities, not just risks. By shifting the horizon away from the short term and contributing to a more sustainable economic trajectory, the financial sector can become a powerful force acting in our collective best interest. The future path for carbon emissions and the climate is uncertain, but it remains within our power to influence it.”<sup>87</sup>

## 1 Introduction

As detailed in the 2023 Sixth Assessment Report of the Intergovernmental Panel on Climate Change (IPCC), human-caused climate change is already having significant impacts in “every region across the globe”, due to observable “widespread and rapid changes in the atmosphere, ocean, cryosphere and biosphere”.<sup>88</sup> There is little doubt that the climate and environmental crisis will affect all sectors of the economy. The financial and banking sectors are no exception. Nevertheless, analysing precisely how environmental considerations should be taken into account in banking regulation is challenging. This is so for the simple reason that, as with many fields of economic regulation, such considerations have not traditionally played a major role in this field. A business-as-usual regulatory approach will therefore not be sufficient.

Banking regulators, globally and in Europe, are stepping up to the challenge.<sup>89</sup> From the prudential regulation perspective, there is now widespread recognition that climate change poses real risks for the banking system and, potentially, systemic risks for the financial system. Legally, this raises the question of the extent to which climate and environmental considerations can lawfully be taken into account in the current prudential regulation framework.

This short contribution offers some reflections on the issue in the specific context of European Union (EU) law. Following a brief overview of recent initiatives on the matter,

---

\* Judge at the General Court since 13 January 2022. The views expressed in this contribution are personal.

<sup>87</sup> Lagarde, C. (2020), “Climate change and the financial sector”, Speech at the launch of the COP 26 Private Finance Agenda, 27 February 2020, available at [https://www.ecb.europa.eu/press/key/date/2020/html/ecb.sp200227\\_1~5eac0ce39a.en.html](https://www.ecb.europa.eu/press/key/date/2020/html/ecb.sp200227_1~5eac0ce39a.en.html).

<sup>88</sup> IPCC (2023), “Summary for Policymakers” in IPCC, *Climate Change 2023: Synthesis Report*, Geneva, A.2.

<sup>89</sup> See, for instance, Carney, M., Villeroy de Galhau, F. and Elderson, F. (2019), *Open letter on climate-related financial risks*, Bank of England, April, noting that “[a]s long as temperatures and sea levels continue to rise and with them climate-related financial risks, central banks, supervisors and financial institutions will continue to raise the bar to address these climate-related risks and to “green” the financial system... Climate change is a global problem, which requires global solutions, in which the whole financial sector has a crucial role to play.”

it offers some observations on the constitutional context for the debate. It concludes with some reflections on the role of the judge in this field.

## 2 The climate challenge in prudential regulation: recent developments

It is helpful to briefly recall the context for the discussion. It is clear that much work has been carried out on the climate and prudential regulation interface in recent years, with many banking regulators publishing policy documents addressing the relevance of climate (and, in some cases, broader environmental) risk to prudential regulation.<sup>90</sup>

At EU level, such developments have taken place against the backdrop of the European Green Deal and, as part of that, its sustainable finance initiatives, which are premised on the idea that the financial system has a “key role” to play as “part of the solution towards a greener and more sustainable economy”.<sup>91</sup> A fundamental aspect of the EU’s approach has been the development of a unified and transparent system for classifying sustainable activities in the form of the EU Taxonomy,<sup>92</sup> which aims at gradual harmonisation of the criteria for determining whether an economic activity qualifies as environmentally sustainable, thus enabling a common, science-based conception of environmentally sustainable activities.

Alongside this, the EU has focused on developing a mandatory corporate disclosure regime. While this focused initially on the financial services sector through the Sustainable Financial Disclosure Regulation,<sup>93</sup> since January 2023 important mandatory sustainability disclosure obligations now apply to a wide range of companies falling within the scope of the Corporate Sustainability Reporting Directive.<sup>94</sup> This followed and built upon amendments to the Directive on disclosure of non-financial information applicable to certain large undertakings and groups, which had already introduced a requirement for undertakings to report information on, amongst other things, environmental matters and respect for human rights.<sup>95</sup> The European Commission is currently considering potential extension of the EU Taxonomy, based upon options outlined by the EU Sustainable Finance Platform.<sup>96</sup> In the particular context of risk management of banks, political agreement was reached

---

<sup>90</sup> The pace of developments is such that one can of course only give a flavour of this work in the space presently available.

<sup>91</sup> European Commission (2018), “Action Plan: Financing Sustainable Growth” (COM(2018) 97 final, 8 March 2018).

<sup>92</sup> Regulation (EU) 2020/852 of the European Parliament and of the Council of 18 June 2020 on the establishment of a framework to facilitate sustainable investment, and amending Regulation (EU) 2019/2088 (OJ L 198, 22.6.2020, p. 13).

<sup>93</sup> Regulation (EU) 2019/2088 of the European Parliament and of the Council of 27 November 2019 on sustainability-related disclosures in the financial services sector (OJ L 317, 9.12.2019, p. 1).

<sup>94</sup> Directive (EU) 2022/2464 of the European Parliament and of the Council of 14 December 2022 amending Regulation (EU) No 537/2014, Directive 2004/109/EC, Directive 2006/43/EC and Directive 2013/34/EU, as regards corporate sustainability reporting (OJ L 322, 16.12.2022, p. 15).

<sup>95</sup> Directive 2014/95/EU of the European Parliament and of the Council of 22 October 2014 amending Directive 2013/34/EU as regards disclosure of non-financial and diversity information by certain large undertakings and groups (OJ L 330, 15.11.2014, p. 1).

<sup>96</sup> EU Platform on Sustainable Finance (2022), *The Extended Environmental Taxonomy: Final Report on Taxonomy extension options supporting a sustainable transition*, March.



in June 2023 on amendment of the Capital Requirements Regulation and the Capital Requirements Directive to ensure the consistent integration of sustainability risks in banks' risks management systems.<sup>97</sup>

In the specific context of prudential supervision, Regulation 2019/2175 has introduced important amendments to the obligations for European Supervisory Authorities (ESAs), obliging them to take into account sustainable business models and the integration of environmental social and governance related factors, and – inter alia – to develop criteria for the identification and measurement of potential environmental-related systemic risk, and to “put in place a monitoring system to assess material environmental social and governance related risks taking into account the Paris Agreement”.<sup>98</sup> That Regulation makes clear the EU legislators' intention, according to which “ESAs should play an important role in identifying and reporting risks that environmental, social and governance related factors pose to financial stability, and in rendering financial markets activity more consistent with sustainability objectives [...]”.<sup>99</sup>

Further, the European Central Bank (ECB) has, in a number of significant publications, addressed the role of climate and environmental factors in prudential regulation. The ECB's Guide on climate-related and environmental risks, published in November 2020, sets out how the ECB expect institutions to consider climate-related and environmental risks in their governance and risk management, as well as to improve their climate and environmental disclosures.<sup>100</sup> The Guide, amongst other things, clearly identifies two principal forms of climate and environmental risk drivers: physical risk, meaning the financial impact of climate change, and transition risk, meaning the financial loss suffered by an institution as a result of the transition to a more sustainable economy.<sup>101</sup>

In line with the expectation set out in this Guide, in its 2022 Thematic Review of banks' capabilities to steer their climate and environmental risk strategies and risk profiles, the ECB concluded that, while banks have overall improved their capabilities since 2021, they “continue to significantly underestimate” climate risks, whether physical or

---

<sup>97</sup> See Council (2023), “Banking sector: Provisional agreement reached on the implementation of Basel III reforms”, 27 June, available at <https://www.consilium.europa.eu/en/press/press-releases/2023/06/27/banking-sector-provisional-agreement-reached-on-the-implementation-of-basel-iii-reforms/>.

<sup>98</sup> Regulation (EU) 2019/2175 of the European Parliament and of the Council of 18 December 2019 amending Regulation (EU) No 1093/2010 establishing a European Supervisory Authority (European Banking Authority), Regulation (EU) No 1094/2010 establishing a European Supervisory Authority (European Insurance and Occupational Pensions Authority), Regulation (EU) No 1095/2010 establishing a European Supervisory Authority (European Securities and Markets Authority), Regulation (EU) No 600/2014 on markets in financial instruments, Regulation (EU) 2016/1011 on indices used as benchmarks in financial instruments and financial contracts or to measure the performance of investment funds, and Regulation (EU) 2015/847 on information accompanying transfers of funds (Text with EEA relevance) (OJ L 334, 27.12.2019, p. 1), Article 1.

<sup>99</sup> *ibid.*, recital 8.

<sup>100</sup> European Central Bank (2020), *Guide on climate-related and environmental risks*, Frankfurt am Main, November.

<sup>101</sup> *ibid.*, p. 10.

transition risks.<sup>102</sup> As part of this assessment process, the ECB set institution-specific deadlines for achieving full alignment with its expectations by the end of 2024.

Further, the ECB's second economy-wide Climate Stress Test, published in 2023, details the substantial credit and market risks that banks would face in the event of delayed transition, and the substantial market risk impact that this would have for non-bank financial institutions including investment funds, insurance corporations and pension funds.<sup>103</sup> The Stress Test concludes, following modelling of three different plausible transition scenarios, that acting "immediately and decisively" in line with the goals of the 2015 Paris Agreement, "would provide significant benefits for the euro area economy and financial system, not only by maintaining the optimal net-zero emissions path (and therefore limiting the physical impact of climate change), but also by limiting financial risk."<sup>104</sup>

In addition, in October 2023 the European Banking Authority (EBA) published its report on environmental and social risks in the prudential framework, pursuant to its mandate under Article 501c of the Capital Requirements Regulation and Article 34 of the Investment Firms Regulation.<sup>105</sup> Article 501c of the Capital Requirements Regulation mandates the EBA to "assess whether a dedicated prudential treatment of exposures related to assets, including securitisations, or activities associated substantially with environmental and/or social objectives would be justified". On the basis of this report, the European Commission "shall, if appropriate" submit a legislative proposal to the European Parliament and to the Council.<sup>106</sup> Article 34 of the Investment Firms Regulation contains a similar requirement in respect of investment firms.<sup>107</sup> In line with this legislative mandate, the EBA Report considers not only climate and environmental, but also social, risks, observing that these risks are "changing the risk picture for the financial sector" and acknowledging the need to enhance the prudential framework in order to better account for them. The Report proposes "targeted" enhancement of the current Pillar 1 framework in the short-term, with additional proposals for the medium and longer term. It also acknowledges the structural difficulty

---

<sup>102</sup> European Central Bank (2022), *Thematic Review on climate and environmental risks 2022. Final Results*, November; European Central Bank (2022), *Good practices for climate-related and environmental risk management: Observations from the 2022 thematic review*, November.

<sup>103</sup> Emambakhsh, T. et al. (2023), "The Road to Paris: stress testing the transition towards a net-zero economy", Occasional Paper Series No. 328, ECB, October, section 6.

<sup>104</sup> *ibid.*, p. 5.

<sup>105</sup> Article 501c of the Capital Requirements Regulation specifies, in this context, that the EBA shall, in particular, assess methodologies for the assessment of the effective riskiness of exposures related to assets and activities associated substantially with environmental and/or social objectives compared to the riskiness of other exposure; the development of appropriate criteria for the assessment of physical risks and transition risks, including the risks related to the depreciation of assets due to regulatory changes; and the potential effects of a dedicated prudential treatment of exposures related to assets and activities which are associated substantially with environmental and/or social objectives on financial stability and bank lending in the Union.

<sup>106</sup> Regulation (EU) No 575/2013 of the European Parliament and of the Council of 26 June 2013 on prudential requirements for credit institutions and investment firms and amending Regulation (EU) No 648/2012 (OJ L 176, 27.6.2013, p. 1).

<sup>107</sup> Article 34 requires an assessment of "whether dedicated prudential treatment of assets exposed to activities associated substantially with environmental or social objectives, in the form of adjusted K-factors or adjusted K-factor coefficients, would be justified from a prudential perspective". See Regulation (EU) 2019/2033 of the European Parliament and of the Council of 27 November 2019 on the prudential requirements of investment firms and amending Regulations (EU) No 1093/2010, (EU) No 575/2013, (EU) No 600/2014 and (EU) No 806/2014 (OJ L 314, 5.12.2019, p. 1).

caused by the fact that observed historical data are traditionally used to assess risk in the prudential regulation, emphasising the need to develop forward-looking models.

Furthermore, as part of a review of the banking macro-prudential framework pursuant to Article 513 of the Capital Requirements Regulation, significant work is ongoing considering how sustainability requirement might be better integrated into this framework to mitigate the systematic risks resulting from climate change.<sup>108</sup> While this work is at an earlier stage than the work on the micro-prudential framework, the European Systemic Risk Board has stated the view that, given the potential risks posed by climate change for the stability of the financial system as a whole, it is crucial to develop sufficient policy tools in advance, to strengthen the system's resilience.<sup>109</sup>

Beyond the EU, at an international level in November 2022 the Basel Committee on Banking Supervision has published its Principles for the effective management and supervision of climate-related financial risks, addressing climate-related financial risks to the global banking system.<sup>110</sup> Last but not least, very significant work has been and continues to be undertaken in the field by the Network for Greening the Financial System (NGFS), the voluntary network of Central banks and Supervisors launched in December 2017 and aimed at sharing best practices and contributing to the development of environmental and climate risk management in the financial sector.

Amongst these initiatives are the NGFS Climate Scenarios, aimed at analysing climate risks to the global economy and financial system, and also, of particular interest from a legal perspective, a Report on micro-prudential supervision of climate-related litigation risks, published in September 2023. The latter Report notes the increasing trend of climate litigation, particularly in certain jurisdictions, and develops principles for assessing the risks deriving from such litigation.<sup>111</sup> Of particular further note is the NGFS's work on ecological and biodiversity risk, with the publication in September 2023 of its Conceptual Framework to guide action by Central Banks and Supervisors in relation to nature-related financial risks.<sup>112</sup> This represents one of the first systematic attempts to consider how this kind of risk might be taken into account in banking regulation.

Despite (or perhaps because of) these significant and rapid developments in integrating climate and environmental concerns into prudential regulation, questions

---

<sup>108</sup> See the responses to the 2021 European Commission targeted consultation on reform of the banking macroprudential framework, available at [https://finance.ec.europa.eu/regulation-and-supervision/consultations/finance-2021-banking-macroprudential-framework\\_en](https://finance.ec.europa.eu/regulation-and-supervision/consultations/finance-2021-banking-macroprudential-framework_en).

<sup>109</sup> European Systemic Risk Board (2022), *Review of the EU Macroprudential Framework for the Banking Sector*, March, 5.2 noting that "complementary macroprudential policy options are needed to address the systemic aspects of climate risk", in addition to analysis of the micro-prudential, institution-level framework.

<sup>110</sup> Basel Committee on Banking Supervision (2022), "Principles for the effective management and supervision of climate-related financial risks", June. See also Basel Committee on Banking Supervision (2022), "Frequently Asked Questions on climate-related financial risks", December, available at <https://www.bis.org/bcbcs/publ/d543.htm>.

<sup>111</sup> NGFS (2023), *Report on micro-prudential supervision of climate-related litigation risks*, September. See also NGFS (2023), *Climate-related litigation: recent trends and developments*, September, providing an overview of climate litigation trends.

<sup>112</sup> NGFS (2023), *Nature-related Financial Risks: a Conceptual Framework to guide Action by Central Banks and Supervisors*, September.

have also been raised about the limits of such integration.<sup>113</sup> As with other fields of economic law in which such considerations have not traditionally played a role, concerns have been raised, for instance, that overextending prudential regulation tools to integrate climate considerations could dilute the *raison d'être* of those tools, and thereby their very legitimacy and efficacy. Furthermore, it has been argued that data on environmental performance of institutions at the micro-prudential level is not yet of sufficient quality or consistent enough to be relied upon, despite the leap forward represented by the EU Taxonomy.<sup>114</sup> An additional common critique is that the ECB, or other supervisory bodies, should not be making environmental policy, as they have neither the expertise nor the mandate to do so.

Such objections merit careful consideration and, in considering them from a legal perspective, it is helpful to reflect on the broader constitutional and legal framework of relevance to this debate. It is also instructive to consider how the courts have tackled analogous questions on the role of environmental considerations to date.

### 3 Constitutional Frameworks

The starting point for any such analysis is naturally Article 127 of Treaty on the Functioning of the European Union (TFEU), which defines the constitutional contours of the role of the European System of Central Banks (ESCB).

As it is well-known, the first sentence of Article 127 TFEU provides that the ESCB's primary objective "shall be to maintain price stability." The second sentence of Article 127 TFEU expressly provides for a supportive role for the ESCB in the broader constitutional context of the EU Treaties, by which it "shall support the general economic policies in the Union with a view to contributing to the achievement of the objectives of the Union as laid down in Article 3 of the Treaty on European Union". It would seem clear that, as part of this secondary mandate, such supportive role, therefore, extends to supporting EU economic policies aiming at contributing to the achievement of the Article 3 TEU objectives of, inter alia, working for the "sustainable development of Europe" and a "high level of protection and improvement of the quality of the environment".<sup>115</sup> In addition, alongside the ESCB's "basic tasks" defined in Article 127(2) TFEU, which include the task of defining and implementing the monetary policy of the EU, Article 127(5) TFEU provides that the ESCB "shall contribute to the

---

<sup>113</sup> See further, the contribution of Veerle Colaert to this volume; see also, Mersch, Y. (2018), "Climate change and central banking", Speech at the Workshop discussion: Sustainability is becoming mainstream, 27 November, available on <https://www.ecb.europa.eu/press/key/date/2018/html/ecb.sp181127.en.html>.

<sup>114</sup> See, for instance, Ernst & Young (2023), "Why organisations should stay the course with their EU taxonomy reporting", October, available at [https://www.ey.com/en\\_gl/assurance/eu-taxonomy-report](https://www.ey.com/en_gl/assurance/eu-taxonomy-report).

<sup>115</sup> There is a broad literature debating the limits of the secondary mandate, much focussing on monetary policy. See, for instance, Ioannidis, M. and Zilioli, C. (2022), "Climate Change and the Mandate of the ECB: Potential and Limits of Monetary Contribution to European Green Policies", *Common Market Law Review*, Vol. 59, No. 2; van 't Klooster, J. and de Boer, N. (2023), "What to Do with the ECB's Secondary Mandate", *Journal of Common Market Studies*, Vol. 61.

smooth conduct of policies pursued by the competent authorities relating to the prudential supervision of credit institutions and the stability of the financial system.”<sup>116</sup>

It might be added that, while it might traditionally have been said that environmental policy and economic policy are separate discrete policy areas, with environmental policies falling exclusively under the environmental chapter of the TFEU, this approach has been overtaken by the acknowledgement that EU economic and environmental policies are often inextricably interlinked. Thus, for instance, the European Green Deal is itself stated to be “a new growth strategy that aims to transform the EU into a fair and prosperous society, with a modern; resource-efficient and competitive economy where there are no net emissions of greenhouse gases in 2050 and where economic growth is decoupled from resource use”.<sup>117</sup>

In many cases, therefore, environmental and economic aims have therefore become fundamentally intertwined and cannot, in any meaningful sense, be separated. Indeed, this approach accords with the constitutional obligation, provided in Article 11 TFEU and Article 37 of the EU Charter of Fundamental Rights, by which environmental protection requirements “must be integrated into the definition and implementation of the Union’s policies and activities, in particular with a view to promoting sustainable development”. It is notable that these Articles provide no exception, for banking supervision or any other field, from this integration obligation.

It should not be overlooked that Article 3(5) TEU provides, as part of the EU’s external objectives, that the Union “shall contribute to the strict observance and the development of international law”. This includes, therefore, the observance of the Paris Agreement agreed under the auspices of the United Nations Framework Agreement on Climate Change,<sup>118</sup> including its aims of “holding the increase in the global average temperature to well below 2°C above pre-industrial levels and pursuing efforts to limit the temperature increase to 1.5°C above pre-industrial levels”, and of “making finance flows consistent with a pathway towards low greenhouse gas emissions and climate-resilient development”.<sup>119</sup> Furthermore, pursuant to Article 216(2) TFEU, international agreements concluded by the EU are binding upon its institutions which, pursuant to Article 13 TEU, include the ECB.

Importantly, however, the second sentence of Article 127 TFEU is stated to be “without prejudice to the objective of price stability”, thereby expressly providing for a hierarchy of ESCB objectives. It would seem, therefore, that any duty to support climate policies as part of the secondary mandate is limited to the extent that it may conflict with objective of price stability. Nevertheless, as has correctly been pointed out, climate and environmental matters may in any event, in their own right, be relevant to and considered in the context of price stability, given the evidence that climate change can

---

<sup>116</sup> On the relation between the ECB’s monetary policy and supervision roles, see Lastra, R. and Psaroudakis, G. (2020), “Prudential Supervisory Tasks” in Amtenbrink, F. and Herrmann, C. (eds.), *The EU Law of Economic and Monetary Union*, Oxford, Oxford University Press.

<sup>117</sup> European Commission (2019), “Communication on the European Green Deal” (COM(2019) 640 final, 11 December 2019).

<sup>118</sup> Paris Agreement to the United Nations Framework Convention on Climate Change, 12 December 2015, T.I.A.S. No. 16-1104.

<sup>119</sup> *ibid.*, Article 2(1).

have direct impacts on price developments.<sup>120</sup> This means, effectively, that Article 127 TFEU allows for two levels of relevance of climate and environmental objectives, both in the primary and secondary mandates.

Also of obvious relevance is the guarantee of independence contained in Article 130 TFEU, which provides that, when exercising the powers and carrying out the tasks and duties conferred upon them by the Treaties and the Statute of the ESCB and of the ECB, “neither the European Central Bank, nor a national central bank, nor any member of their decision-making bodies shall seek or take instructions from Union institutions, bodies, offices or agencies, from any government of a Member State or from any other body”. As held by the Court of Justice of the European Union (CJEU) in its *OLAF* judgment, Article 130 TFEU “seeks, in essence, to shield the ECB from all political pressure in order to enable it effectively to pursue the objectives attributed to its tasks, through the independent exercise of the specific powers conferred on it for that purpose by the EC Treaty and the ESCB Statute”.<sup>121</sup>

Nevertheless, it would seem difficult to argue that this guarantee prevents the ECB, in coming to its own interpretation of the tasks conferred upon it by EU law, from having regard to general legislation validly passed by the EU legislator, including in the climate and environmental fields, such as the Taxonomy legislation or indeed, for instance, the EU climate neutrality objective contained in the European Climate Law.<sup>122</sup>

Moreover, it could be argued that the ECB is, in having regard to such legislation as appropriate, giving effect to the constitutional integration obligation contained in Articles 11 TFEU and Article 37 of the Charter, set out above. For instance, general legislation passed by the EU legislator may validly be of assistance to the ECB in considering, concretely, what constitutes “environmental protection requirements” within the meaning of these Articles in any given case. Indeed, such an approach, entailing having regard to environmental standards already agreed, may help to address criticisms, mentioned above, that actors such as the ECB should not be “making” environmental policy. This may include, for instance, definitions of “sustainable” activities agreed in the context of the EU Taxonomy or the Corporate Sustainable Reporting Directive, considered above.

Furthermore, while the precise manner in which substantive integration of environmental protection requirements is achieved, and different policy objectives are balanced, may be a matter for the institution at issue, there are good arguments that, at the very least, Article 11 TFEU entails a procedural duty to explain concretely and

---

<sup>120</sup> See, for instance, Facci, D., Parker, M. and Stracca, L. (2021), “Feeling the heat; extreme temperatures and price stability”, Working Paper Series No 2626, ECB, December.

<sup>121</sup> Case C-11/00, *Commission v European Central Bank*, ECLI:EU:C:2003:395, para. 134.

<sup>122</sup> Regulation (EU) 2021/1119 of the European Parliament and of the Council of 30 June 2021 establishing the framework for achieving climate neutrality and amending Regulations (EC) No 401/2009 and (EU) 2018/1999 (‘European Climate Law’) (OJ L 243, 9.7.2021, p. 1). The ECB is not expressly mentioned amongst the institutions listed in recital (34) of the European Climate Law. While the Article 2 obligation to take the “necessary measures” to implement the Union’s binding objective of climate neutrality by 2050 may therefore not apply to it, it may validly have regard to that binding Union objective, within the constitutional limits imposed by the Treaty.

transparently how environmental protection requirements have been taken into account, in accordance with the Article 296 TFEU duty to give reasons.<sup>123</sup>

It could also be argued that, as a provision of primary EU law, relevant secondary legislation should be interpreted in the light of Article 11 TFEU and Article 37 of the Charter, as far as possible.<sup>124</sup> Since 2019, the ESA Regulation, as aforementioned, in any event expressly obliges ESAs to take into account sustainable business models and the integration of environmental social and governance related factors. In addition, pursuant to Article 4(3)(3) of the Single Supervisory Mechanism (SSM) Regulation, in carrying out its supervisory tasks provided for under the Regulation, the ECB “shall apply all relevant Union law”, which would appear to support the view that the SSM should be viewed as part of a coherent system of law, and does not constitute an area of EU law that should be in any sense insulated from relevant climate/environmental legislation.<sup>125</sup> That perspective would in turn appear consistent with recital (32) of the SSM Regulation, by which the ECB “should carry out its tasks subject to and in compliance with relevant Union law including the whole of primary and secondary Union law [...]”.

It is perhaps worth returning to one final feature of note in the applicable constitutional framework, namely, the third sentence of Article 127(1) TFEU which, in detailing the ESCB’s mandate, provides that it “shall act in accordance with the principle of an open market economy with free competition, favouring an efficient allocation of resources, and in compliance with the principles set out in Article 119(3).” On one argument, this statement might be interpreted as supporting the view that the ECB cannot validly have regard to climate and environmental objectives, as these fall outside the economic efficiency objective, narrowly conceived. However, as has been persuasively observed, as a result of environmental externalities due to insufficient carbon pricing mechanisms, climate risk pricing is currently distorted on the market. Internalising such externalities may, thus, correct this inefficiency.<sup>126</sup>

On this point, it is interesting to note an analogous discussion in the context of EU competition policy, where the question of whether climate and environmental aims are compatible with economic efficiency objectives has been debated for some years. This debate has resulted in the publication, in 2023, of a revised version of the European Commission’s Horizontal Cooperation Guidelines, which contain a substantial new section clarifying how sustainability benefits may in fact be considered themselves to contribute to objective economic efficiencies, and discussing how various environmental valuation techniques, such as valuation of use-value and non-use

---

<sup>123</sup> See further, Nowag, J. (2016), “The Environmental Integration Obligation of Article 11 TFEU”, in Nowag, J. (ed.), *Environmental Integration in Competition and Free-Movement Laws*, Oxford, Oxford University Press; and, in the context of monetary policy, Calliess, C., and Tuncel, E. (2023), “The Role of Article 11 TFEU in the Greening of the ECB’s Monetary Policy”, *German Law Journal*, Vol. 24, No. 5.

<sup>124</sup> Indeed, the CJEU has in the past interpreted international law (in that case, the international law principle of territoriality) in the light of Article 11 TFEU: see Case C-366/10, *ATAA*, ECLI:EU:C:2011:864.

<sup>125</sup> Council Regulation (EU) No 1024/2013 of 15 October 2013 conferring specific tasks on the European Central Bank concerning policies relating to the prudential supervision of credit institutions (OJ L 287, 29.10.2013, p. 63), Article 1.

<sup>126</sup> See Schnaebel, I. (2021), “Climate change, financial markets and green growth”, Speech at the ECB DG-Research Symposium “Climate change, financial markets and green growth”, 14 June, available at <https://www.ecb.europa.eu/press/key/date/2021/html/ecb.sp210614~162bd7c253.en.html>, and literature cited.

benefits, and collective benefits, can be integrated into traditional competition analysis.<sup>127</sup> In taking this approach, the Guidelines expressly acknowledge market failures occurring through environmental negative externalities arising from production and consumption decisions, which are not sufficiently taken into account by the economic operators or consumers that cause them. While noting that public policies and regulation may be appropriate to address these market failures, the Guidelines conclude that residual market failure may, in certain cases, be addressed by private economic actors and therefore fall to be dealt with by competition law.<sup>128</sup>

In this field of EU economic law also, therefore, the idea of a bright line distinction between “environmental” and “economic” benefits has been rejected. Here also, competition authorities apply the Guidelines as independent bodies, but acting within a constitutional context set by the Treaties and having regard to any applicable environmental legislation.

Finally, the CJEU’s approach to the role of climate and environmental considerations in a related field of economic law, State aid, is also of interest. In its 2020 Grand Chamber judgment in *Hinkley Point*, which concerned a challenge to the European Commission’s State aid approval of a nuclear power station, the CJEU analysed the balance between environmental and State aid objectives under Article 107 TFEU. Applying Article 37 of the Charter and Article 11 TFEU, it held that State aid for an economic activity falling within the nuclear sector that is shown upon examination to contravene rules of EU law on the environment cannot be declared compatible with the internal market pursuant to the State aid rules.<sup>129</sup>

In that case however, in light in particular of the fact that Article 194 TFEU leaves the choice of energy mix to Member States, no conflict arose. In this respect, therefore, the *Hinkley Point* judgment suggests that, subject to any express conditions set out in the Treaty (in that case, Article 194 TFEU), the CJEU may be open to interpreting provisions of EU economic law in the light of the environmental integration obligation contained in Article 37 of the Charter and Article 11 TFEU, as far as possible.

## 4 Conclusory reflections on the judicial role in the environment and prudential supervision debate

In light of the above, and in particular the recent rapid developments in the field of greener banking supervision highlighted above, it is appropriate to conclude with some reflections on the role of judges in this context. This role is at least twofold.

A first role is that of classic judicial review in controlling the legality of supervisors’ actions in the field of banking law. As has been correctly observed by Tridimas, the number of such cases before the Court of Justice and General Court has increased

---

<sup>127</sup> Communication from the Commission – Guidelines on the applicability of Article 101 of the Treaty on the Functioning of the European Union to horizontal co-operation agreements (OJ C 259, 21.7.2023, p. 1), section 9.

<sup>128</sup> *ibid.*, recital 519.

<sup>129</sup> Case C-594/18 P, *Austria v Commission*, ECLI:EU:C:2020:742, para. 44.



exponentially in recent years, a shift which he notes, “has to be seen in the wider context of the colonization of economic governance and financial regulation by EU law, a tectonic shift that has increased the involvement of the CJEU in those areas.”<sup>130</sup> Much has been written about the appropriate standard of judicial review of in this field, and particularly about the appropriate standard of review of ECB actions, including in the field of prudential supervision.<sup>131</sup> As it has been noted, the CJEU has reaffirmed on multiple occasions that the legality of the ECB’s actions is, in accordance with the principles of the rule of law, subject to judicial review before it.<sup>132</sup> In its *Crédit Lyonnais* judgment of May 2023, the Court set out a helpful confirmation of the principles and standard of judicial review in cases where the ECB enjoys discretion, including in the field of prudential supervision, which it is worth recalling here:<sup>133</sup> “[a]s the General Court pointed out, in essence, in paragraph 98 of the judgment under appeal, in so far as the ECB has a broad discretion in deciding whether or not to apply Article 429(14) of Regulation No 575/2013, the judicial review which the Courts of the European Union must carry out of the merits of the grounds of a decision such as the decision at issue must not lead it to substitute its own assessment for that of the ECB, but seeks to ascertain that that decision is not based on materially incorrect facts and that it is not vitiated by a manifest error of assessment or misuse of powers [...]”.

In that regard, it is settled case-law that the Courts of the European Union must, *inter alia*, establish not only whether the evidence relied on is factually accurate, reliable and consistent but also whether that evidence contains all the relevant information which must be taken into account in order to assess a complex situation and whether it is capable of substantiating the conclusions drawn from it [...].

Where an institution enjoys broad discretion, observance of procedural guarantees is of fundamental importance, including the obligation for that institution to examine carefully and impartially all the relevant aspects of the situation in question [...]”.

Considering the intensity of judicial review in that case, Advocate General Emiliou observed that “there is no single and specific intensity of judicial review that is valid in all circumstances where the EU institutions enjoy some degree of (policy or technical) discretion as to how a particular rule should be applied...the ‘marginal’ review that the EU Courts have generally alluded to may be more marginal or less marginal, depending on the specific circumstances of each case. It is thus for the EU Courts to determine, on a case-by-case basis, in the light of all relevant circumstances, the specific intensity of review to be applied when reviewing an institution’s use of discretion.”<sup>134</sup>

---

<sup>130</sup> Tridimas, T. (2022), “The ECB and the Court of Justice: Old Toolbox, New Problems” in Beukers, T., Fromage, D. and Monti, G. (eds.), *The New European Central Bank*, Oxford, Oxford University Press, p. 293.

<sup>131</sup> *ibid.* See also Rosas, A. (2021), “EMU in the Case Law of the Union Courts: A General Overview and some Observations”, *European Papers*, Vol. 6, No. 3, p. 1397; Zilioli, C. and Wojcik, K.-P. (eds.) (2021), *Judicial Review in the European Banking Union*, Elgar.

<sup>132</sup> See for instance, Case C-11/00, *Commission v European Central Bank*, ECLI:EU:C:2003:395, para. 125, and Article 35(1) of Protocol (No 4) on the Statute of the European System of Central Banks and of the European Central Bank (OJ C 202, 7.6.2016, p. 230) (ECB Statute).

<sup>133</sup> Case C-389/21 P, *ECB v Crédit Lyonnais*, ECLI:EU:C:2023:368, paras. 55-57; case citations omitted.

<sup>134</sup> *ibid.*, para. 76.

Thus, as has also been observed, in cases which were held not to involve significant discretion but to be of a more technical nature involving the application or interpretation of supervisory legislation, a more intensive standard of review has been applied.<sup>135</sup> It follows that the standard of judicial review of integration of climate/environmental concerns in prudential supervision will ultimately depend on whether, on the facts of the case, the specific regulatory context is such that the ECB enjoys broad discretion. This will in particular be so where the decision at stake entails complex assessments involving balancing of policy choices, such as the precise means by, or extent to which, which climate and environmental assessments should be taken into account by supervisors.

A second, and perhaps less obvious, role of the courts in this context – this time, on a global level – is as the source of an increasing number of climate judgments feeding into the assessment of micro-prudential climate litigation risk. As correctly observed by the NGFS in its 2023 report on the issue, climate-related litigation has become an important risk driver for financial institutions, due to the rapid growth and evolution of such litigation in recent years.

This includes a rising number of cases against corporate defendants such as fossil fuel and energy companies, but also against financial institutions themselves, based on claims such as greenwashing, breaches of director's duties and violation of corporate due diligence laws.<sup>136</sup> It also includes increasing numbers of systemic climate litigation, taken against State defendants but with potentially considerable knock-on consequences for private economic actors, where judges are being asked to go beyond traditional conceptions of judicial review to examine whether the current evidence on climate performance meets with the legal obligations, including new climate laws but also human rights obligations, to which States have agreed.<sup>137</sup>

In sum, in this rapidly developing area at a crucial intersection of banking and climate and environmental law, there can be little doubt that courts will play an increasingly important role.

---

<sup>135</sup> See Tridimas (2022) (n 44) and Rosas (2021) (n 45).

<sup>136</sup> For a helpful overview of such litigation, see NGFS (2023), *Climate-related litigation: recent trends and developments*, September, and the Grantham Research Institute on Climate Change and the Environment, "Global Trends in Climate Change Litigation: 2023 snapshot", June, available at [https://www.c40knowledgehub.org/s/article/Global-trends-in-climate-change-litigation-2023-snapshot?language=en\\_US](https://www.c40knowledgehub.org/s/article/Global-trends-in-climate-change-litigation-2023-snapshot?language=en_US).

<sup>137</sup> For examples of systemic climate litigation, see Higham, C. et al. (2023), "Climate change law in Europe: What do new EU climate law mean for the courts?", Policy Report, Grantham Research Institute on Climate Change and Environment, March. There are currently three climate cases pending before the Grand Chamber of the European Court of Human Rights, *Verein Klimasenioren Schweiz v Switzerland*, *Carême v France* and *Duarte Agostinho v Portugal and 32 Other States*.

# Incorporating climate and environmental considerations in prudential regulation and supervision of financial risks: an open and iterative approach

Juliana B. Bolzani\*

## 1 Introduction

For central banks and banking supervisory agencies facing daunting challenges related to climate and other environmental risks (C&E risks),<sup>138</sup> the main question today is how they can react to the existential threat of climate change and other nature-related harms (such as biodiversity loss and ecosystem degradation). In this contribution, I argue that central banks and banking supervisory agencies do not need to receive a new and specific mandate to support a green transition. Government entities with the legal duty to preserve financial stability cannot simply turn their backs on the climate and environmental emergency while waiting for a new legal authority. Ensuring that financial institutions properly assess and manage C&E risks is not

---

\* Juliana B. Bolzani is senior counsel at the Legal Department of the International Monetary Fund (IMF). The views expressed here are those of the author and do not necessarily represent the views of the IMF, its Executive Board, or its management. The author would like to thank Alessandro Gullo and Mario Tamez for their insightful comments and suggestions, as well as Kika Alex-Okoh for superb research assistance.

<sup>138</sup> Central banks and banking supervisory agencies initially focused on climate risks but have been recently including other nature-related risks in their research and policies related to financial risks. See NGFS, *Statement on nature-related financial risks* (24 March 2022), [https://www.ngfs.net/sites/default/files/medias/documents/statement\\_on\\_nature\\_related\\_financial\\_risks\\_-\\_final.pdf](https://www.ngfs.net/sites/default/files/medias/documents/statement_on_nature_related_financial_risks_-_final.pdf); Sabine Mauderer, *Climate change, biodiversity loss and the role of central banks* (11 May 2023), <https://www.bis.org/review/r230511a.pdf>. All environmental damage can result in material financial risks, come it from carbon emissions or from any other kind of environmental threat to the planet's land, air, waters or biodiversity. However, risk assessment and management of all environmental risks is a more complex task than the already challenging endeavour of understanding and dealing with climate risks. For example, the tools used to minimize one kind of environmental risk may have the side-effect of exacerbating climate risk or a different kind of environment risk. See, for example, the discussion about the trade-off between reversing environmental damage and using land to build wind farms and other renewable projects, in the European Union, or the concerns about the environmental damage caused by mining the raw materials used in the manufacturing of electric vehicles' batteries, as well as the disposal of those batteries. Financial Times, *EU law to restore nature stokes debate that jobs will 'go to China'* (30 April 2023), <https://www.ft.com/content/a68259ce-cc28-4869-8e6b-9cfa7fb0a7c>; New York Times, *How green are electric vehicles?* (9 November 2021), <https://www.nytimes.com/2021/03/02/climate/electric-vehicles-environment.html>. See also WEF Report, p. 8 (for an explanation on how nature loss and climate change are intrinsically interlinked); Pietro Calice et al., *Biodiversity and finance: A preliminary assessment of physical risks for the banking sector in emerging markets*, Policy Research Working Paper 10432 (May 2023), World Bank Group, p. 2, <https://documents1.worldbank.org/curated/en/099526305022388443/pdf/IDU0e52335a30e0f804949088f30d8c4eee5cee8.pdf> (concluding that financial institutions already exposed to climate-related risks may also face the combined effects arising from the interaction between biodiversity loss, climate change, and natural disasters).

optional for central banks and banking supervisory agencies whose legal mandates include promoting financial stability.<sup>139</sup>

As C&E risks can become material financial risks, central banks and banking supervisory agencies must, at the very least, assess whether their models are able to capture C&E risks.<sup>140</sup> There is no need to start from scratch and create something new. They can refine what already exists by, for example, incorporating C&E risks into their supervisory framework, as many central banks and banking supervisory agencies have already started to do.<sup>141</sup>

C&E risks are usually classified as physical or transition risks. Physical risks can manifest through acute or chronic climate or environmental events that cause damage to property, infrastructure, and land. This damage, in turn, brings down the value of assets owned by financial institutions, including credit assets.<sup>142</sup> Transition risks arise from changes in technology, government policy, and consumer and investor sentiment associated with the transition to a green economy that also end up affecting the value of an institution's assets.

The degree of incorporation of climate and environmental considerations into prudential supervision at the national level will vary depending on the tool that is adopted and the powers the enabling statute grants to the central bank or supervisor in each jurisdiction. For example, the results from stress tests and other diagnostic tools may uncover previously unknown C&E risks and eventually lead to changes in capital requirements.<sup>143</sup> However, in many jurisdictions limitations to central banks and banking supervisory agencies' statutory authority will likely impede actions not directly connected to their financial-stability mandate, such as credit incentives to green activities or green liquidity assistance.<sup>144</sup>

---

<sup>139</sup> See François Villeroy de Galhau, The role of central banks in the "macroeconomics of climate change" (24 April 2023), pp. 2-3, <https://www.bis.org/review/r230425h.pdf>.

<sup>140</sup> See BCBS, *Climate-related risk drivers and their transmission channels* (April 2021) v-vi, <https://www.bis.org/bcbss/publ/d517.pdf> (for definitions of physical and transition risks). C&E risks are financial risks not only for financial institutions and other firms, but also for countries. See World Bank Group, *Brazil Country Climate and Development Report* (4 May 2023), <https://openknowledge.worldbank.org/handle/10986/39782> (forecasting that near 10 % of Brazil's GDP would be at risk if damage to the Amazon forest passes a key inflection point, with the possibility of three million people falling into extreme poverty).

<sup>141</sup> See FSB, *Supervisory and regulatory approaches to climate-related risks*, Final report (13 October 2022), <https://www.fsb.org/wp-content/uploads/P131022-1.pdf>.

<sup>142</sup> Physical risks are also important on the liability side of the balance sheet for insurers and reinsurers because more frequent and intense weather events and disasters lead to an increase in the frequency and amounts of insurance claims. Pierpaolo Grippa et al., *Climate change and financial risk* (December 2019), <https://www.imf.org/en/Publications/fandd/issues/2019/12/climate-change-central-banks-and-financial-risk-grippa>.

<sup>143</sup> See Todd Phillips, What are climate-adjusted capital requirements? (21 February 2023), Green Central Banking, <https://greencentralbanking.com/2023/02/21/climate-adjusted-capital-requirements/> (describing data and legal obstacle for the implementation of climate-adjusted capital requirements and providing an overview of the current position of multilateral standard setters and individual countries on the issue). See also Patrizia Baudino and Jean-Philippe Svoronos, Stress-testing banks for climate change—a comparison of practices (July 2021), FSI Insights on policy implementation No 34, <https://www.bis.org/fsi/publ/insights34.pdf>, p. 2 (reporting that the introduction of new capital requirements on the basis of the outcomes of climate stress tests is not presently favoured given the preliminary nature of the stress tests and the high level of uncertainty of their results).

<sup>144</sup> See, e.g., Eric Lonergan and Megan Greene, *Dual Interest Rates Give Central Banks Limitless Fire Power*, VoxEU (3 September 2020), <https://voxeu.org/article/dual-interest-rates-give-central-banks-limitless-fire-power>.

At the international level, many central banks and banking supervisory agencies are now members of the Network for Greening the Financial System (NGFS).<sup>145</sup> The NGFS develops research, builds capacity, enables the exchange of experiences across jurisdictions, and provides guidance with the objective of better understanding and responding to C&E risks. Notable progress has been made since the NGFS was founded in 2017, with most central banks and banking supervisory agencies advancing in developing clear strategies, implementing governance changes, and allocating resources to address C&E risks. However, progress on environmental risks in general – as opposed to climate risks – has been slower.<sup>146</sup>

International coordination and cooperation in relation to the regulation of C&E risks are essential to inhibit spillover effects and regulatory arbitrage, as well as to reduce compliance costs for multinational financial institutions.<sup>147</sup> Regarding the supervision of C&E risks, coordination and cooperation have been facilitated by international organizations, fora, and standard-setting bodies connecting central banks and banking supervisory agencies and providing them with better tools and data to assess those types of risks with a certain degree of consistency.<sup>148</sup>

The International Monetary Fund (IMF) has increasingly included exposure to climate risks and associated policy options as an integral part of the Financial Sector Assessment Programs (FSAPs), relying on climate scenarios developed by the NGFS and informing the supervisory authorities' understanding of those risks.<sup>149</sup> The Basel Committee on Banking Supervision (BCBS), with its Task Force on Climate-related Financial Risks (TCFR), and the Financial Stability Board (FSB), who created the Taskforce for Climate-related Financial Disclosures (TCFD), have also evolved to consider how C&E risks relate to their mission and how these risks can be integrated into prudential regulation and supervision across jurisdictions.

---

<sup>145</sup> As of June 13, 2023, the NGFS consists of 127 members and 20 observers. NGFS, *Membership, Membership* | Banque de France (ngfs.net)

<sup>146</sup> See NGFS, *Progress report on the Guide for Supervisors* (October 2021), p. 6, [https://www.ngfs.net/sites/default/files/media/2021/11/08/progress\\_report\\_on\\_the\\_guide\\_for\\_supervisors.pdf](https://www.ngfs.net/sites/default/files/media/2021/11/08/progress_report_on_the_guide_for_supervisors.pdf)

<sup>147</sup> See European Systemic Risk Board (ESRB), *Review of the EU macroprudential framework for the banking sector: Concept note* (March 2022), p. 51, <https://www.esrb.europa.eu/pub/pdf/reports/esrb.reviewmacropruframework.220331-65e86a81aa.en.pdf> (highlighting that macroprudential policy for climate risks will have to consider cross-sectoral and cross-border issues to avoid arbitrage and waterbed effects because of the universal nature of climate change). But see Roberta Romano, *For diversity in the international regulation of financial institutions: Critiquing and Recalibrating the Basel Architecture*, 31 *Yale J. on Reg.* 1, 66 (2014) (warning about possible downsides of internationally-harmonized financial regulation, such as challenges in predicting optimal regulatory policies to reduce systemic risk in dynamic markets and fewer opportunities for experimentation across jurisdictions).

<sup>148</sup> But see Beck et al. (2023), *Incomplete coverage in supervisory cooperation and cooperation externalities*, [https://www.bankingsupervision.europa.eu/press/conferences/shared/pdf/20230502\\_research\\_conference/Wagner\\_paper.pdf](https://www.bankingsupervision.europa.eu/press/conferences/shared/pdf/20230502_research_conference/Wagner_paper.pdf).

<sup>149</sup> See Tobias Adrian et al., *Approaches to climate risk analysis in FSAPs* (14 July 2022), [https://www.ngfs.net/sites/default/files/media/2021/11/08/progress\\_report\\_on\\_the\\_guide\\_for\\_supervisors.pdf](https://www.ngfs.net/sites/default/files/media/2021/11/08/progress_report_on_the_guide_for_supervisors.pdf)

Relatedly, the main focus of current C&E risk policies is on Pillar 2 of the Basel framework and encompasses supervision and non-capital buffers.<sup>150</sup> In June 2022, the BCBS published Pillar 2 principles for the effective management and supervision of climate-related financial risks, announcing that it will monitor the implementation of these principles across jurisdictions.<sup>151</sup> The Pillar 2 supervisory review process “aims to ensure that banks have adequate capital and liquidity to support their underlying risks, especially risks that are not covered or not fully covered by Pillar 1.”<sup>152</sup> Pillar 2 also seeks “to ensure that risk management and internal controls at each bank are aligned with its overall risk profile.”<sup>153</sup> Moreover, changes to Pillar 1 capital requirements in attention to C&E risks, not introduced until now, may become possible if focused on forward-looking assessment, such as those based on transition plans, and supported by methodology advances and improvements in the quality and consistency of data and taxonomies.<sup>154</sup> The BCBS has recently published a set of frequently asked questions clarifying how climate-related financial risks may be captured in the existing Pillar 1 framework for regulatory capital.<sup>155</sup>

Revisiting the traditional concepts of micro- and macro-prudential regulation and supervision, this chapter discusses how climate and environmental considerations can be immediately incorporated into financial regulation and supervision. It argues that open-ended rules favoured by a principles-based approach combined with iterative supervision can be a valuable strategy to assess and manage C&E risks in the

<sup>150</sup> “At this point, further discussion and analytical work among supervisors and with other stakeholders is required when considering Pillar 1 treatment and stress testing for Pillar 2 capital requirements, due to limited adequate/reliable data, nascent methodologies and a lack of common definitions, classifications and taxonomies and evidence of risk differentials between ‘green’ and ‘non-green’ assets. Other Pillar 2 processes such as ICAAP and ORSA may be useful as starting points to incorporate these risks.” NGFS, *Progress report on the Guide for Supervisors* (October 2021), Technical document, p. 9, [https://www.ngfs.net/sites/default/files/progress\\_report\\_on\\_the\\_guide\\_for\\_supervisors\\_0.pdf](https://www.ngfs.net/sites/default/files/progress_report_on_the_guide_for_supervisors_0.pdf). See also Rodrigo Coelho and Fernando Restoy, *The regulatory response to climate risks: some challenges* (February 2022), p. 5, <https://www.bis.org/fsi/fsibriefs16.pdf>. ECB, (November 2022), thematic review, p. 7, <https://www.bankingsupervision.europa.eu/ecb/pub/pdf/ssm.thematicreviewcerreport112022-2eb322a79c.en.pdf> (noting that “the principles-based nature of the Pillar 2 framework provides authorities with sufficient flexibility to more effectively address climate-related financial risks”).

<sup>151</sup> See Basel Committee on Banking Supervision (BCBS), *Principles for the effective management and supervision of climate-related financial risks* (June 2022), <https://www.bis.org/bcb/publ/d532.pdf>.

<sup>152</sup> Rodrigo Coelho et al., *Rising interest rates and implications for banking supervision* (May 2023), FSI Briefs, p. 6, <https://www.bis.org/fsi/fsibriefs19.pdf>.

<sup>153</sup> *ibid.*

<sup>154</sup> A greater exposure of non-green assets to transition risks can result in risk differentials that would require adjustment factors into Pillar 1 capital requirements. NGFS, *Capturing risk differentials from climate-related risks* (May 2022), p. 4, [https://www.ngfs.net/sites/default/files/medias/documents/capturing\\_risk\\_differentials\\_from\\_climate-related\\_risks.pdf](https://www.ngfs.net/sites/default/files/medias/documents/capturing_risk_differentials_from_climate-related_risks.pdf). See also Bank of England, PRA, *Climate-related financial risk management and the role of capital requirements: Climate change adaptation report 2021* (28 October 2021), Executive Summary, viii-ix; Bank of England, *Bank of England report on climate-related risks and the regulatory capital frameworks* (13 March 2023), p. 31, <https://www.bankofengland.co.uk/prudential-regulation/publication/2023/report-on-climate-related-risks-and-the-regulatory-capital-frameworks> (welcoming research on the issue of climate change and capital frameworks to ascertain whether the latter adequately capture climate risks).

<sup>155</sup> See Basel Committee on Banking Supervision (BCBS), *Frequently asked questions on climate-related financial risks* (8 December 2022), <https://www.bis.org/bcb/publ/d543.pdf>. See also the NGFS’ exploration of the supporting evidence for introducing adjustment factors into Pillar 1 capital requirements based on the greenness of an asset. NGFS, *Capturing risk differentials from climate-related risks* (May 2022), p. 7, [https://www.ngfs.net/sites/default/files/medias/documents/capturing\\_risk\\_differentials\\_from\\_climate-related\\_risks.pdf](https://www.ngfs.net/sites/default/files/medias/documents/capturing_risk_differentials_from_climate-related_risks.pdf) (concluding that “given the current data and methodological limitations, introducing adjustment factors in the Pillar 1 capital framework using conventional risk differential analysis based on historical data remains a challenge”).

financial sector without delay. The contribution also recommends the deployment of supervisory guidance followed by scenario analysis and stress testing as the best way to implement the proposed strategy. The idea is to have flexible rules that create space for adaptive guidance coupled with supervisory tools that can offer ongoing monitoring to inform adjustments as reality changes. Importantly, there is no one-size-fits-all solution. The ideal balance between forms of regulation and levels of supervisory discretion will differ across jurisdictions and should be tailored to local circumstances and needs.

## 2 Micro- and macro-prudential regulation and supervision

Prudential regulation and supervision have two slightly different objectives, namely (i) preserving the safety and soundness of individual financial institutions through the application of micro-prudential policies and tools that can protect creditors of these institutions, and (ii) promoting the stability of the financial system with the use of macro-prudential policies and tools aimed at safeguarding the overall economy.<sup>156</sup>

Given the complementarity between micro- and macro-prudential goals, some policies and tools can be used for both purposes without a clear distinction – stress testing and capital requirements being good examples here.<sup>157</sup> On the other hand, policies and tools meant to address macro-prudential concerns, notably those with counter-cyclical effects, can adversely affect the balance sheet of individual financial institutions in the short term.<sup>158</sup> This happens because macro-prudential actions are often taken in credit booms, when the immediate risk posed by individual financial institutions might be low, but risks are building up in the financial system as a whole. Take for instance counter-cyclical capital buffers, which are commonly activated in good times and released during economic downturns.<sup>159</sup>

One of the main objectives of macro-prudential policy is to compensate for a financial institutions' tendency to underestimate broader risks in boom cycles, making itself

---

<sup>156</sup> See Andrew Crockett, *Marrying the micro- and macro-prudential dimensions of financial stability* (21 September 2000), Speech, <https://www.bis.org/speeches/sp000921.htm> (proposing that the micro- and the macro-prudential dimensions of financial stability differ in the “objectives of the tasks and of the conception of the mechanisms influencing economic outcomes,” rather than in the “instruments used in the pursuit of those objectives.”). See also Claudio Borio, *Towards a macroprudential framework for financial supervision and regulation?* (February 2003), BIS Working Papers No 128, <https://www.bis.org/publ/work128.pdf>. See also Turalay Keç, *Macroprudential regulation: History, theory and policy*, BIS Papers No 86, p. 5 (stating that macroprudential regulation is justified to the extent that the social cost of market failures caused by negative externalities “exceed both the private costs of failure and the extra costs of regulation.”). See also Donato Masciandaro and Marc Quintyn, “The Evolution of Financial Supervision: The Continuing Search for the Holy Grail” (2013), in Morten Balling and Ernest Gnan (eds.), *50 Years of Money and Finance: Lessons and Challenges*, pp. 263-318, p. 264 (describing how the global financial crisis of 2007-2009 led to the “full development of macro-prudential supervision as a new policy domain next to the traditional, and henceforth called, micro-prudential supervision.”).

<sup>157</sup> See Tomasz Dubiel-Teleszynski et al., *System-wide amplification of climate risk* (13 June 2022), *Macroprudential Bulletin*, European Central Bank (ECB). See also Lev Menand, *Too big to supervise*, *103 Cornell L. Rev* 1527, (2018), p. 1581 (explaining that the stress tests conducted by the Federal Reserve System have both micro- and macro-prudential objectives); Hockett (2014), pp. 221-222 (noting that capital requirements have macro-prudential effects when applied to multiple institutions or countercyclically).

<sup>158</sup> See Frédéric Boissay and Lorenzo Ciappello, *Financial Stability Review* (May 2014), European Central Bank (ECB).

<sup>159</sup> See Pablo Hernández de Cos, *Making macroprudential policy fit for the next decade* (20 June 2022), <https://www.bis.org/review/r220621n.pdf>

more vulnerable in the process.<sup>160</sup> Minimizing the destabilizing effect of credit expansion and leverage, for instance, is the rationale behind Basel III rules imposing counter-cyclical capital surcharges and liquidity requirements, both components of the Basel framework conceived in the aftermath of the 2007-2009 global financial crisis.<sup>161</sup>

Before any discussion on how C&E risks affect the financial system, financial regulators had already acknowledged that the narrow short-term risk assessment performed by the private sector needs to be complemented by government policies that also require the consideration of broader long-term risks.<sup>162</sup> The “tragedy of the horizon” brought by climate change and environmental loss would only reinforce the justification for policies that correct this trend toward short-termism and ensure that long-term risks are properly measured.<sup>163</sup>

As stated in the Basel Core Principles for effective banking supervision, which set standards for the sound functioning of the banking sector, supervisory authorities must assess financial risks “in a broader context than that of the balance sheet of individual banks.”<sup>164</sup> Even when primarily focused on the safe and soundness of individual financial institutions, supervisors should not lose sight of a perspective that considers the macroeconomic reality, business trends, and concentration of risk inside and outside the financial sector. Climate change and environmental losses are examples of factors coming from outside the financial sector that affect the risk exposure of individual banks.

It is thus doubtful that micro-prudential regulation alone is enough to capture and contain C&E risks as their effect on the financial system is likely to be systemic, especially in the case of a disorderly green transition. For example, transition shocks can cause an abrupt correction in asset prices that results in the fire-sale of assets.<sup>165</sup> At the same time, central banks and banking supervisory agencies have yet to deepen their understanding of the contagion mechanisms and procyclicality of C&E risks in

---

<sup>160</sup> See Robert Hockett, *The macroprudential turn: From institutional safety and soundness to systematic financial stability in financial supervision*, 9 VA. L. & Bus. Rev. p. 201, p. 214 (2015) (noting that the key policy objective of macroprudential supervision is to counteract booms, acting countercyclically); European Systemic Risk Board (ESRB), *Review of the EU macroprudential framework for the banking sector: Concept note* (March 2022), p. 3, <https://www.esrb.europa.eu/pub/pdf/reports/esrb.reviewmacropruframework.220331-65e86a81aa.en.pdf> (stating the macroprudential policy’s aim of reducing the probability and impact of financial crises).

<sup>161</sup> See Markus Brunnermeier et al., *The fundamental principles of financial regulation* (June 2009), Geneva Reports on the World Economy 11, p. 32, [https://cepr.org/system/files/publication-files/68579-geneva\\_11\\_the\\_fundamental\\_principles\\_of\\_financial\\_regulation.pdf](https://cepr.org/system/files/publication-files/68579-geneva_11_the_fundamental_principles_of_financial_regulation.pdf) (naming this strategy a “lean against the wind” risk-management approach).

<sup>162</sup> See Andrew Baker, *Macroprudential regimes and the politics of social purpose*, 25(3) Review of International Political Economy, p. 293, p. 303 (2018), <https://doi.org/10.1080/09692290.2018.1459780> (citing procyclicality as one of the defining features of macroprudential approaches to financial regulation, founded on the belief that “financial market participants have difficulty in calculating the time dimensions of risk, because short-time horizons produce extrapolations of current conditions into the future resulting in misperceptions of risk”). Research has shown that regulators too are prone to underestimate risks during credit booms, leading to regulatory cycles of strict regulation in economic downturns and lax regulation during economic expansions. Julie A. Hill, *Bank capital regulation by enforcement: An empirical study*, 87 Ind. L.J. p. 645, p. 697 (2012).

<sup>163</sup> See Mark Carney, *Breaking the tragedy of the horizon: climate-change and financial stability* (29 September 2015), <https://www.bankofengland.co.uk/-/media/boe/files/speech/2015/breaking-the-tragedy-of-the-horizon-climate-change-and-financial-stability.pdf>

<sup>164</sup> BCBS, *Core Principles for effective banking supervision* (15 December 2019), p. 8, para. 1.17, [https://www.bis.org/basel\\_framework/chapter/BCP/01.htm?inforce=20191215&published=20191215](https://www.bis.org/basel_framework/chapter/BCP/01.htm?inforce=20191215&published=20191215)

<sup>165</sup> See FSB and NGFS, *Climate scenario analysis by jurisdictions: Initial findings and lessons* (15 November 2022), p. 24.



the financial system.<sup>166</sup> Trying to move forward with detailed and individualized rules might be counterproductive then. In any case, the financial-stability component present in most regulators' mandates already requires them to incorporate C&E physical- and transition-related exogenous shocks as sources of systemic risk and to adopt adequate macro-prudential policies in response.<sup>167</sup> Macro-prudential regulation seems thus to provide a more immediate path to deal with C&E risks, even though macro-prudential frameworks cannot address specific situations related to individual institutions.

In light of this reality, what is then the best regulatory approach to make sure that financial institutions take into consideration broader long-term risks in their risk assessment? At first glance, requirements and limitations should be imposed by detailed regulation and not by open-ended rules, which allows ample supervisory discretion, for reasons similar to those invoked to support the use of rules rather than discretion in monetary policy.<sup>168</sup> Without clear prescriptive rules, supervisors may amass too much power. Also, excessive discretion may, in principle, expose supervisors to more pressure from the government and the regulated industry, each trying to push its own agenda.<sup>169</sup>

On the other hand, a macro-prudential policy implemented by prescriptive rules might fail to promptly capture the time-varying manifestations of systemic risks, especially when they are difficult to measure, like C&E risks. In this case, more discretion coupled with supervisory independence and accountability might deliver the best outcome.<sup>170</sup> It is then worthy to assess these regulatory strategies and understand how they compare.

---

<sup>166</sup> See Mercy B. DeMenno, *Environmental sustainability and financial stability: can macroprudential stress testing measure and mitigate climate-related systemic financial risk?*, J. of Banking Reg. (2022), <https://doi.org/10.1057/s41261-022-00207-2>.

<sup>167</sup> See Matthias Täger and Simon Dikau, *Purposeful scenario analysis: A framework to guide central banks and financial supervisors in the selection and design of climate scenarios* (May 2023), p. 7, <https://www.lse.ac.uk/granthaminstitute/wp-content/uploads/2023/05/Purposeful-scenario-analysis-Policy-insight.pdf> (posing that scenario analysis can contribute to assessing financial stability implications of climate-related shocks).

<sup>168</sup> But see Itai Agur and Sunil Sharma, *Rules, discretion, and macro-prudential policy* (2013), IMF Working Paper WP/13/65, pp. 10-11, <https://www.imf.org/external/pubs/ft/wp/2013/wp1365.pdf> (describing relevant differences in the process of making macro-prudential policy from that of monetary policy).

<sup>169</sup> See Geneva Reports (2009) (n 24), p. 37; Agur and Sharma (2013) (n 31), p. 11 (identifying that measurement uncertainty related to systemic risk makes macro-prudential regulation and supervision more susceptible to political pressure than monetary policy).

<sup>170</sup> See BCBS, *Core Principles for effective banking supervision* (15 December 2019), Principle 2—Independence, accountability, resourcing and legal protection for supervisors, [https://www.bis.org/basel\\_framework/chapter/BCP/01.htm?inforce=20191215&published=20191215](https://www.bis.org/basel_framework/chapter/BCP/01.htm?inforce=20191215&published=20191215). See also Agur and Sharma (2013) (n 31), pp. 4-10 (explaining how the difficulties in measuring systemic risk weaken the case for a macro-prudential policy based on rules); Agustín Carstens, *Investing in banking supervision* (1 June 2023), <https://www.bis.org/speeches/sp230601.htm>, (stating that “the ability and will of supervisors to take early and forceful action when needed are predicated on supervisors having operational independence, appropriate powers and legal protection”).

### 3 Regulation, supervision and supervisory discretion

Financial regulation is the set of administrative rules that apply to banks and other financial institutions. Central banks and banking supervisory agencies issue these rules to fill in the gaps of legislation imposing obligations on financial institutions and fulfil their legal mandates to preserve financial stability, promote market discipline, and protect consumers. Supervision, in turn, consists of all the actions these authorities take to ensure the regulated industry's compliance with the rules, from monitoring and examining conducts to sanctioning violators.<sup>171</sup> The more detailed the rules, the less discretion supervisors will have in deciding how these rules should be interpreted and applied. Conversely, the less detailed the rules, the more flexibility supervisors will have while performing their functions. For some legal scholars, however, financial supervision goes beyond the mere implementation of rules. It is rather a mechanism to administer risk and manage moral hazard when rules are not capable of efficiently doing so.<sup>172</sup>

Despite these differences, the terms 'regulation' and 'supervision' are often used interchangeably, or the term 'regulation' is used in a broad sense that encompasses both regulation and supervision.<sup>173</sup> But in this contribution I treat these terms separately to emphasize the value of supervisory discretion as a tool to deal with C&E risks in the financial sector. Although the rules-versus-discretion debate is far from new, it can be revisited and reimagined to build new outcomes.

In monetary policy, this debate is the basis of a well-known economic theory arguing that rules constraining the options of policy responses are optimal because they translate into commitments that neutralize the effects of the 'time-inconsistency' paradox.<sup>174</sup> Kydland and Prescott explain the mechanism of this 'time inconsistency': "if the policy rule is believed and used to form expectations of future policy by private agents, the government has an incentive to deviate from it later on, inducing 'policy surprises'.<sup>175</sup> Because private agents are rational, the possibility of 'policy surprises' shapes their expectations around future policy actions – rational agents anticipate that policymakers' decisions will change as a result of changing economic conditions and adapt their behaviour accordingly.<sup>176</sup> This process, in turn, leads policymakers to effectively change the policy based on a prediction as to the final expectations of

---

<sup>171</sup> See Masciandaro and Quintyn (2013) (n 19).

<sup>172</sup> See Peter Conti-Brown and Sean Vanatta, Risk, Discretion, and Bank Supervision (2023). See also Lev Menand, *Why supervise banks? The foundations of the American Monetary Settlement*, Vand. L. Rev., Vol. 74(1) (2021).

<sup>173</sup> See Thomas Eisenbach et al., *Supervising Large, Complex Financial Institutions: What Do Supervisors Do?*, Econ. Pol'y Rev. 57,58 (February 2017) (noting how the terms 'regulation' and 'supervision' do not always convey distinct meanings), <https://go.exlibris.link/Fkbn8KZM>; Daniel K. Tarullo, Bank supervision and administrative law, 2022 Colum. Bus. L. Rev. p. 279, p. 399 (2022); Masciandaro and Quintyn (2013) (n 19), p. 263.

<sup>174</sup> Finn E. Kydland and Edward C. Prescott, *Rules rather discretion: The inconsistency of optimal plans* (1977), J. Pol. Econ., Vol. 85, pp. 473-91. See also Bruno Salama, The art of law & macroeconomics, pp. 158-159 (2012) (pinning the origins of Kydland and Prescott's preference for rules over discretion on the monetarist tradition of Milton Friedman and others and on the liberal tradition defending the "rule of law" as opposed to the "rule of men").

<sup>175</sup> Guido Tabellini, *Kydland and Prescott's contribution to macroeconomic policy*, 107(2) The Scandinavian J. Econ. p. 203, p. 208 (June 2005), <http://www.jstor.com/stable/3441102>.

<sup>176</sup> See Kydland and Prescott (1977) (n 37), p. 474.

private agents.<sup>177</sup> This iterative process reduces the benefits of a policy with too many or flexible response options.<sup>178</sup> And that is why rules limiting discretion, or the possible policy responses under different circumstances, would be a preferred solution for monetary policy.

Building on these arguments, Harvard Professor Kenneth Rogoff proposes an alternative to overcome the time-inconsistency problem identified by Kydland and Prescott. Instead of having a rigid monetary rule to promote price stability, governments should opt for a 'conservative central-banker': a central banker with institutional independence from the whims of elected governments who, relative to society in general, favours a lower rate of inflation.<sup>179</sup> Contrary to what happens under the prescriptive-rules approach defended by Kydland and Prescott, discretion is not held in such an unfavourable light in the central-bank independence framework. However, in both cases – prescriptive rules and central-bank independence – the idea is that credibility, commitment, and predictability are conducive to more effective policies.<sup>180</sup>

The classification of regulation as principles-based or rules-based is another framework to approach administrative discretion that can be used to analyse the interaction between regulation and supervision.<sup>181</sup> Principles-based regulation is made of high-level rules setting the standards for the regulated industry's behaviour.<sup>182</sup> It focuses on outcomes, maximizes the breadth of application, and contains terms that are qualitative rather than quantitative, increasing senior management responsibility when applying the rules.<sup>183</sup> Rules-based regulation, in turn, provides the regulated

---

<sup>177</sup> *ibid.*, p. 478.

<sup>178</sup> "If the policy rule is selected by the government once and for all, without subsequent re-planning, then rational private agents will adapt their expectations taking this policy rule into account, and this is the end of the story. If, instead, policy choice is sequential, and it is made period after period, then the policymaker is subject to an incentive constraint. Private expectations will not adjust to any pre-announced policy rule. Rational expectations will instead reflect the equilibrium policy choice of future periods. Current policy decisions can only influence future expectations to the extent that current policies affect future equilibrium outcomes. This incentive constraint limits what the government can achieve and results in reduced government welfare, compared to the situation in which binding policy commitments are feasible." Guido Tabellini, *Kydland and Prescott's contribution to macroeconomic policy*, 107(2) *The Scandinavian J. Econ.* p. 203, p. 209 (June 2005), <http://www.jstor.com/stable/3441102>.

<sup>179</sup> See Kenneth Rogoff, *The Optimal Degree of Commitment to an Intermediate Target*, *Q. J. Econ.* 100 (1985), pp. 1169-1190. See also Yves Mersch, *Monetary policy and time inconsistency in an uncertain environment* (11 September 2006), p. 5, <https://www.bis.org/review/r060915a.pdf>. The preoccupation with time inconsistency is the main theoretical basis for a defence of politically independent central banks and extends to financial regulation and supervision, including with respect to C&E risks. See also Paul Tucker, *The design and governance of financial stability regimes*, 3 CIGI Essays on International Finance (September 2016), p. 48, [https://www.cigionline.org/static/documents/financial\\_essay\\_vol3\\_web.pdf](https://www.cigionline.org/static/documents/financial_essay_vol3_web.pdf) (positing that effective dynamic macroprudential policy relies on credible commitment and emphasizing the importance of an institutional framework capable of delivering credibility). See also Masciandaro and Quintyn (2013) (n 19), pp. 291-292.

<sup>180</sup> See Milton Friedman, *Should there be an independent monetary authority* (1962), in L.B. Yeager (ed.), *In Search of a Monetary Constitution*, pp. 219-243. Cambridge, Harvard University Press (presenting both alternatives but rejecting the idea of central-bank independence because it would give wide discretion to a body not subject to direct and effective political control").

<sup>181</sup> See Louis Kaplow, *Rules Versus Standards: An Economic Analysis*, 42 *Duke L.J.* p. 557, pp. 559-563 (1992); Cass Sunstein, *Problems with Rules*, 83 *Calif. L. Rev.* p. 953, pp. 957-959 (1995); Kathleen Sullivan, *Foreword: The Justices of Rules and Standards*, 106 *Harv. L. Rev.* p. 22, pp. 23-24 (1992).

<sup>182</sup> See Julia Black et al., *Making a success of principles-based regulation*, 1 *Law and Financial Markets Review* 191 (May 2007), <https://www.lse.ac.uk/law/people/academic-staff/julia-black/Documents/black5.pdf>

<sup>183</sup> *ibid.*

industry with more detailed instructions and bright-line rules on how to design and implement risk-management processes.<sup>184</sup>

The difference between principles-based and rules-based regulation, however, is not always clear-cut, as the inquiry on the meaning of a regulatory command can vary in objectivity, a given provision is often 'more' or 'less' based on principles or standards depending on how ample its semantic perimeter is.<sup>185</sup> In general, however, rules-based financial regulation limits the work of financial supervisors by permitting them narrower discretion to identify risks and advance risk-management processes. A principles-based regulation allows supervisors more discretion to fill in the blanks of broad guidelines and standards.<sup>186</sup>

The more regulation is made of principles rather than rules, the more discretion supervisors will have to anticipate non-linear risks (such as C&E risks) and tailor their reaction to each institution's characteristics. Nimbleness in supervision can provide authorities with more efficient mechanisms to incorporate climate and environmental considerations into prudential policies. Discretion also facilitates the application of the principle of proportionality, which is central in the Basel Core Principles for effective banking supervision and recommends that supervisors calibrate their actions in accordance with the systemic importance and risk profile of each individual institution.<sup>187</sup> Similarly, Principle 16 of the BCBS' Principles for the effective management and supervision of climate-related financial risks states that "supervisors should set expectations in a manner proportionate to the nature, scale and complexity of relevant banks' activities."<sup>188</sup>

On the other hand, reliance on the flexibility of supervisory actions may raise due process concerns. First, excessively intrusive supervisory intervention such as sanctions may be inconsistent with administrative law when based on open-ended rules and not on bright-line rules that provide fair warning to the regulated industry. Second, the absence of detailed rules can also stimulate the use of 'regulation by enforcement' as a strategy to unduly avoid requirements typical to rulemaking, such

---

<sup>184</sup> See Heath P. Tarbert, *Rules for principles and principles for rules: Tools for crafting sound financial regulation*, 10 Harv. Bus. L. Rev. ONLINE.

<sup>185</sup> See Menand (2018) (n 20), p. 1536; Lawrence Cunningham, *A Prescription to Retire the Rhetoric of Principles-Based Systems in Corporate Law, Securities Regulation, and Accounting*, 60 Vand. L. Rev. pp. 1409, pp. 1421 (2007) (pointing out that the idea of a continuum from principle to rule takes away much of the usefulness and rigor of the "rules vs. principles" classification of individual provisions).

<sup>186</sup> According to Harvard University law professor and former member of the Fed's Board of Governors Daniel Tarullo, rules-based regulation also tends to be more costly for the regulated industry: "If banking agencies are deprived of important supervisory tools and respond with some combination of blunter and inflexibly detailed regulatory rules, the result could be a higher regulatory cost for many forms of intermediation." See Tarullo (2022) (n 36).

<sup>187</sup> See Core Principles, p. 4, para. 1.3. The proportionality principle is adopted by most central banks and banking supervisory agencies, such as the Federal Reserve, which supervises bank holding companies, savings and loans holding companies, and state member banks of varying size and complexity: "The Federal Reserve follows a risk-focused approach by scaling supervisory work to the size and complexity of an institution." Board, Supervision and regulation report (May 2023), p. 15, <https://www.federalreserve.gov/publications/files/202305-supervision-and-regulation-report.pdf>

<sup>188</sup> BCBS, *Principles for the effective management and supervision of climate-related financial risks* (June 2022), <https://www.bis.org/bcbs/pub/d532.htm>. See also comments on the principles' application to the US at <https://www.mayerbrown.com/en/perspectives-events/publications/2022/06/climate-risk-management-principles-finalized-by-basel-committee>

as opportunity for public comment and cost-benefit analysis.<sup>189</sup> Third, because principles-based regulation allows a wider variation in interpretation, it is more likely that similar situations are treated differently by supervisors.

Central banks and banking supervisory agencies can address these concerns by ensuring that their measures rely on robust reasoning and follow internal guidance previously and publicly issued. Even so, non-prescriptive rules can lead to supervisory lethargy or paralysis. Without a clear mandate to act, supervisors might become wary of using the full spectrum of their discretionary power and, as a result, exposing themselves to a greater degree of political or judicial scrutiny or even backlash.<sup>190</sup>

## 4 The case for principles-based regulation to deal with C&E risks

In the present situation of multiple global crises (from the Covid pandemic to the war in Ukraine) leading to increased uncertainty over inflation, interest rates, and other macroeconomic indicators, the argument for principles-based financial regulation has gained traction, although the degree and modalities of its actual implementation vary across jurisdictions.<sup>191</sup> The lingering climate and environmental emergencies seem to reinforce the argument in favour of principles-based financial regulation. C&E risks themselves are uncertain, tend to materialize in a long-term horizon, and have their assessment supported by a body of data that is rapidly evolving in quality and granularity. Alluding to the uncertainty of C&E risks, the Bank for International Settlements (BIS) has described climate change as a 'green swan' because of its "interacting, nonlinear, fundamentally unpredictable, environmental, social, economic and geopolitical dynamics."<sup>192</sup> Therefore, a principles-based regulation of C&E risks is probably more capable than a rules-based regulation of keeping up with the constant factual changes and successfully protecting financial stability.

---

<sup>189</sup> See James D. Cox, *Headwinds Confronting the SEC*, 18 N.C. Banking Inst. p. 105, p. 107 (2013). N.C. Banking Institute.

<sup>190</sup> See Menand (2018) (n 20), p. 1586 ("Outside of CCAR, we might expect supervisors, facing political, professional, and legal risks from the exercise of discretion, to be drawn to the bureaucratic safe harbour offered by procedural interpretations of safety and soundness and the inarguable clarity of bright-line rules. Proceduralism, after all, reduces conflict between supervisors in the field and senior officials in Washington, as well as with bank executives, Congressional representatives opposed to supervisory discretion, and agency lawyers, who themselves prefer the certainty of rules."). See also Nick Robins, *Sustainable central banking: clear green water between the Fed and the ECB?* (18 January 2023), LSE Business Review, <https://blogs.lse.ac.uk/businessreview/2023/01/18/sustainable-central-banking-clear-green-water-between-the-fed-and-the-ecb/>.

<sup>191</sup> See Richard Bookstaber, *US approach to financial regulation is set up to fail* (1 May 2023), Financial Times, <https://www.ft.com/content/837502bd-ab33-4b7b-93c0-412bd235cbbd?desktop=true&segmentId=d8d3e364-5197-20eb-17cf-2437841d178a#myft.notification:instant-email:content>. See Adam Tooze, *Welcome to the world of the polycrisis*, Financial Times (28 October 2022), <https://www.ft.com/content/498398e7-11b1-494b-9cd3-6d669dc3de33>; World Economic Forum, *Global Risks Report 2023* (January 2023), p. 9 (stating that, in a polycrisis, "disparate crises interact such that the overall impact far exceeds the sum of each part"), <https://www.weforum.org/agenda/2023/01/polycrisis-global-risks-report-cost-of-living/>, John Kay and Mervyn King, *Radical Uncertainty: Decision-making Beyond the Numbers* (2021), Norton, (definition of "radical uncertainty").

<sup>192</sup> BIS (green swan). The term "green swan" inspired Nicholas' Taleb "black swans": apparently unpredictable events that have an enormous impact and that people fail to consider when making a decision but after the fact acknowledge were actually more predictable and less random than they initially thought. Nassim Nicholas Taleb, *The Black Swan: The Impact of the Highly Improbable* (2d ed. 2010).

Also, it is more feasible to reach an international consensus on principle-based regulation than on specific and granular rules, favouring the international consistency required to tackle climate and environmental challenges.<sup>193</sup> Given the global nature of C&E risks and financial markets, financial regulation based on international practice and, thus, comparable across jurisdictions could be more effective than highly prescriptive rules that vary from one jurisdiction to the other and invariably lead to regulatory arbitrage.

But do C&E risks really need to be treated as a separate risk category? C&E risks are material risks that fit the traditional taxonomy of financial risks: physical and transition risks can be classified as credit, market, liquidity, or operational risks, or as drivers to these categories of risk.<sup>194</sup> For example, transition risks in the form of legislative or regulatory changes inhibiting the use of fossil fuels can increase the credit risk for financial institutions whose counterparties are heavily dependent on the general level of consumption of fossil fuels. Moreover, in terms of litigation risk, a subcategory of operational risk, financial institutions or their counterparties might become the target of lawsuits alleging, for example, that a climate-related event or an environmental disaster is a result of their economic activities.<sup>195</sup> Litigation risk, in particular, is a risk not only for the regulated industry, but also for regulators and supervisors, whose actions and scope of authority regarding environmental matters may be subject to judicial review.<sup>196</sup>

Under this light, financial institutions could integrate C&E risks into their risk management processes by filing them under one of the more traditional risk categories and the job would be done. A few central bankers have argued as much, advocating that financial regulators should not treat C&E risks differently than they treat other kinds of risk.<sup>197</sup> On the other hand, evidence exists showing that the financial system has not paid enough attention to C&E risks or does not have the full expertise and sufficient data to properly integrate these risks into their traditional risk

---

<sup>193</sup> See Tarbert (n 47), p. 17.

<sup>194</sup> See Rodrigo Coelho and Fernando Restoy (n 13).

<sup>195</sup> See summons filed by non-governmental organizations (NGOs) before the Judicial Court of Paris against BNP Paribas alleging responsibility in Amazon deforestation and human rights violations, claiming that the bank has violated the French law on duty of diligence. Columbia Law School, Sabin Center for Climate Change Law, *Comissão Pastoral da Terra and Notre Affaire à Tous v. BNP Paris*, Climate Change Litigation Databases, Global Climate Change Litigation, <http://climatecasechart.com/non-us-cases/comissao-pastoral-da-terra-and-notre-affaire-a-tous-v-bnp-paribas/>. For more examples of climate-related litigation risks, see NGFS, Climate-related litigation: *Raising awareness about a growing source of risk* (November 2021), [https://www.ngfs.net/sites/default/files/medias/documents/climate\\_related\\_litigation.pdf](https://www.ngfs.net/sites/default/files/medias/documents/climate_related_litigation.pdf)

<sup>196</sup> In Brazil, for example, federal prosecutors have filed lawsuits (civil public actions) against the Central Bank of Brazil claiming the central bank's failure to supervise securities brokers and distributors that purchase gold originated from illegal mining in the Amazon. André Schroder, *Yanomami crisis sparks action against illegal gold in the Amazon* (28 February 2023), Mongabay, <https://news.mongabay.com/2023/02/yanomami-crisis-sparks-action-against-illegal-gold-in-the-amazon/>.

<sup>197</sup> See Christopher J. Waller, Climate change and financial stability (11 May 2023), <https://www.federalreserve.gov/newsevents/speech/files/waller20230511a.pdf> (arguing that climate risks "are not sufficiently unique or material to merit special treatment relative to others"). Governor Waller, from the Board of Governors of the Federal Reserve System, does not support the Board's issuing guidance on climate-related financial risk management for large financial institutions. Board, *Statement by Governor Waller on principles for climate-related financial risk management for large financial institutions* (2 December 2022), Press release, <https://www.federalreserve.gov/newsevents/pressreleases/waller-statement-20221202.htm>.

management.<sup>198</sup> For instance, the 2022 ECB supervisory assessment has found that only 17 % of the covered institutions has disclosed comprehensively how C&E risks have been integrated into their risk management processes.<sup>199</sup> This is precisely another reason in favour of financial supervisors with enough discretion not only to nudge financial institutions into taking C&E risks seriously but to require more engagement when needed.

This is not to say that assessing C&E risks is easy. One of the main challenges in improving the risk management of C&E risks in a financial institution is data gaps, partially due to a lack of standardized disclosures.<sup>200</sup> Investors and other stakeholders, including central banks and banking supervisory agencies, need high-quality and granular data on the exposure of financial institutions to C&E risks to adequately measure and price those risks.<sup>201</sup> The quality of this data, however, is highly dependent on the disclosures made by non-financial companies, who are the financial institutions' clients and counterparties.<sup>202</sup>

So, rules-based regulation may be preferable to principles-based regulation as an end-goal for mandatory disclosures.<sup>203</sup> Quantitative components and specific elements that can only be set by rules are necessary to properly measure risk, compare disclosures, and consequently be useful for decision-making purposes.<sup>204</sup> The preference for rules-based regulation to achieve granular disclosure of C&E risks does not invalidate the defence of immediately using principles-based regulation for other areas of financial regulation and supervision related to C&E risks. In practice, most regulatory regimes are composed of a mixture of both principles-based and rules-

---

<sup>198</sup> See BIS, p. 1, <https://www.bis.org/bcbs/publ/d518.pdf> (claiming that climate-related financial risks have unique features—they necessitate granular and forward-looking measurement methodologies—that are not completely absorbed in existing processes); Financial Stability Board (FSB), *FSB roadmap for addressing climate-related financial risks* (7 July 2021), p. 1, <https://www.fsb.org/wp-content/uploads/P070721-2.pdf> (defending that climate risks differ from other risks to financial stability); Bank of England, PRA, *Supervisory Statement SS3/19*, pp. 3-4 (listing the distinctive elements of the financial risks from climate change).

<sup>199</sup> See ECB, *The importance of being transparent: A review of climate-related and environmental risks disclosures practices and trends*, p. 25, <https://www.bankingsupervision.europa.eu/ecb/pub/pdf/ssm.theimportanceofbeingtransparent042023-1f0f816b85.en.pdf> (April 2023).

<sup>200</sup> Climate-related data gaps can result from deficiencies in availability, reliability, and comparability. NGFS, *Final report on bridging data gaps* (July 2022), p. 4, <https://www.bis.org/bcbs/publ/d309.pdf>; NGFS, *Progress report on bridging data gaps* (May 2021), [https://www.ngfs.net/sites/default/files/medias/documents/final\\_report\\_on\\_bridging\\_data\\_gaps.pdf](https://www.ngfs.net/sites/default/files/medias/documents/final_report_on_bridging_data_gaps.pdf). These three dimensions of data gaps are interconnected: reliability issues, for example, can impair data comparability. See FSB, *The availability of data with which to monitor and assess climate-related risks to financial stability* (July 2021), p. 19 (noting that "differences in the construction of ESG ratings across providers prevent them from supplying consistent and comparable information on transition risks across firms and jurisdictions").

<sup>201</sup> See Madison Condon, *Market myopia's climate bubble*, 2022 Utah L. Rev. 63 (2021), [https://scholarship.law.bu.edu/faculty\\_scholarship/1087?utm\\_source=scholarship.law.bu.edu%2Ffaculty\\_scholarship%2F1087&utm\\_medium=PDF&utm\\_campaign=PDFCoverPages](https://scholarship.law.bu.edu/faculty_scholarship/1087?utm_source=scholarship.law.bu.edu%2Ffaculty_scholarship%2F1087&utm_medium=PDF&utm_campaign=PDFCoverPages), for an explanation of how mispricing of climate-related risks into asset prices occur.

<sup>202</sup> See Financial Stability Board (FSB), *Progress report on climate-related disclosures* (13 October 2022), p. 14, <https://www.fsb.org/wp-content/uploads/P131022-2.pdf>.

<sup>203</sup> The BCBS plans to issue a consultation paper on a proposed framework for Pillar 3 disclosures of climate-related financial risks. Bank for International Settlements (BIS), *Basel Committee to review recent market developments, advances work on climate-related financial risks, and reviews Basel Core Principles* (23 March 2023), Press release, <https://www.bis.org/press/p230323a.htm>.

<sup>204</sup> See Task-Force on Climate-related Financial Disclosures (TCFD), *Recommendations of the Task Force on Climate-related Financial Disclosures* (June 2017), p. 52, <https://assets.bbhub.io/company/sites/60/2021/10/FINAL-2017-TCFD-Report.pdf> (recommending that disclosures be specific and complete, as a principle for effective disclosures).

based regulation so that supervisory discretion exists in a spectrum.<sup>205</sup> Prescriptive rules establishing processes for risk management and disclosures should coexist with, rather than replace, open-ended rules that give supervisors broader discretionary authority to oversee the substance of C&E risks, such as the effect of risk-appetite, risk-identification, and risk-mitigation policies of a given institution over its resilience and the stability of the financial system.<sup>206</sup>

Prescriptive rules for mandatory disclosures can also coexist with international standards that, albeit non-binding, promote open-ended rules aimed at achieving regulatory consistency across jurisdictions to minimize the risk of regulatory arbitrage and reduce compliance costs.<sup>207</sup> Take the example of what happened in the aftermath of COP26, when the public and private sectors, individually or congregated in international organizations and I, have started working to bridge the climate data gap. They have been developing taxonomies and disclosure standards that facilitate data comparability around the world.<sup>208</sup> Moreover, building on the work of the TCFD and other reporting initiatives, the International Sustainability Standards Board (ISSB) issued initial global baseline climate reporting standards to ensure that disclosures are made on a common basis and, at the same time, allow national and regional jurisdictions to set supplemental standards that fulfil their local disclosure needs.<sup>209</sup> Under the Basel framework, the BCBS is also exploring the possibility to incorporate disclosure of C&E risks in its Pillar 3 standards, which aim to reduce information asymmetry as a means to promote financial stability.<sup>210</sup>

---

<sup>205</sup> See Dan Awrey, *Regulation financial innovation: A more principles-based proposal*, 5 Brook. J. Corp. Fin. & Com. L. p. 273, pp. 275-276 (2011); Lawrence A. Cunningham (2007), p. 1426 (adding that descriptions of entire systems as "principles-based" or "rules-based" must assess "not only the character of all individual provisions, but also how the provisions are applied and how they interact).

<sup>206</sup> See Menand (2018) (n 20), p. 1532.

<sup>207</sup> See FSB, *Progress report on climate-related disclosures (2022)* (n 65), p. 6.

<sup>208</sup> See, e.g., IMF, *Climate Change Indicators Dashboard*, <https://climatedata.imf.org> (making available a statistical tool linking climate considerations and global economic indicators); NGFS, *Final report on bridging data gaps* (July 2022) [https://www.ngfs.net/sites/default/files/medias/documents/final\\_report\\_on\\_bridging\\_data\\_gaps.pdf](https://www.ngfs.net/sites/default/files/medias/documents/final_report_on_bridging_data_gaps.pdf) (releasing a living directory of climate-related data sources and identifying the main climate-related data gaps); Glasgow Financial Alliance for Net Zero (GFANZ), *Financial institution net-zero transition plans (November 2022)*, Executive Summary, xv, <https://assets.bbhub.io/company/sites/63/2022/10/Financial-Institutions-Net-zero-Transition-Plan-Executive-Summary.pdf> (issuing recommendations for transition plans for financial institutions, including suggestions on disclosure content).

<sup>209</sup> See IFRS Foundation, *Climate-related disclosures*, <https://www.ifrs.org/projects/work-plan/climate-related-disclosures/#current-stage>. The ISSB's formation was announced in 2021 at COP26 in Glasgow and it's backed by the G7, the G20, the International Organization of Securities Commissions (IOSCO), the Financial Stability Board (FSB), African Finance Ministers and finance ministers and central bank governors from more than 40 jurisdictions. IFRS Foundation, *About the International Sustainability Standards Board*, <https://www.ifrs.org/groups/international-sustainability-standards-board/>. The ISSB is also developing standards on general sustainability-related disclosures. IFRS Foundation, *General sustainability-related disclosures*, <https://www.ifrs.org/projects/work-plan/general-sustainability-related-disclosures/>.

<sup>210</sup> See BCBS, *Basel Committee supports the establishment of the International Sustainability Standards Board* (3 November 2021), Press release, <https://www.bis.org/press/p211103.htm>



## 5 Supervising C&E risks: iterative supervision through supervisory guidance

As a result of the openness or tightness of rules' commands, prudential supervision goes beyond monitoring compliance with prescriptive rules. It also involves fulfilling open mandates, such as guaranteeing the 'safe and soundness' of financial institutions. This process, in turn, demands the use of supervisory discretion to adjust the application of broader rules to the specific situation of individual institutions, as when the supervisor requires capital levels above the regulatory minimum in light of an institution's particular circumstances.<sup>211</sup> These open mandates derive from principles-based regulation, considering the breadth of the commands they contain and the resulting scope of discretion they give supervisors.<sup>212</sup> As such, the prudential supervision of risks, following a gradual and dialectic process, enables supervisors to interpret this kind of open-ended rules and to fulfil regulatory gaps.<sup>213</sup>

This strategy is particularly fitting to deal with C&E risks because of the gaps in quantity and quality of data input that inform the assessment of these risks, their inherent uncertainty, and the dynamism of financial markets.<sup>214</sup> As such, open-ended rules – favoured by a principles-based approach – combined with a collaborative and escalating supervisory approach should be more effective than a prescriptive set of narrowly formulated rules whose violation leads automatically to enforcement actions and administrative sanctions.<sup>215</sup>

Combining open-ended rules with an iterative approach to supervision also allows regulators and the regulated industry to learn together how to incorporate C&E risks into their risk frameworks, sharing information and expertise, as well as disseminating

---

<sup>211</sup> See Julie A. Hill (2012), pp. 656-657; Menand (2018) (n 20). See also Board, *Understanding Federal Reserve Supervision*, About Bank Supervision (27 April 2023), <https://www.federalreserve.gov/supervisionreg/understanding-federal-reserve-supervision.htm>

<sup>212</sup> See Michelle W. Bowman, *The evolving nature of banking, bank culture, and bank runs* (12 May 2023), p. 12, <https://www.bis.org/review/r230515c.pdf> (arguing that supervision must complement regulation "to address emerging threats and risks by allowing supervisors to pivot to those fundamental risks that may be most salient based on that bank's business model and evolving economic conditions.").

<sup>213</sup> See Chris Brummer et al., *Regulation by Enforcement* (30 March 2023), S. Cal. L. Rev., forthcoming, p. 4, footnote 4, <https://ssrn.com/abstract=4405036> (explaining that "the regulatory toolkit comprises an array of formal and more informal levers that extend along a continuum of intensity between fulsome rulemaking and enforcement actions" and highlighting that, "in addition to the hard power visible in rulemaking and enforcement, agencies can deploy 'softer,' situational and tailored mechanisms like interpretative guidance, press releases, no-action and exemptive letters or public statements and speeches that can indicate the direction of agency thinking and regulatory priorities.").

<sup>214</sup> See Tarullo (2022) (n 36), p. 281 (defining supervision as "an iterative process of communication between banks and supervisors").

<sup>215</sup> According to Tim Wu, dynamic industries are those undergoing rapid change and dealing with facts that are unclear and evolving, often because the industry is hit by external shocks, such as disruptive innovation, unexpected market entry, and the rise of a new business model. In dynamic industries, Wu proceeds, regulators face a situation of "high uncertainty", to which they can adequately respond by issuing "agency threats." Agency threats, for the author, are non-legislative and non-binding rules, such as letters, speeches, and guidance documents, in which the regulator threatens the industry to enforce or enact a rule, specifying the industry's desired behaviour. Tim Wu (2011), *Agency threats*, pp. 1842, 1848-1849. See also Jacob E. Gersen and Eric A. Posner, *Soft law: Lessons from Congressional Practice*, 61 Stan. L. Rev. pp. 573, 588, 607, 620 (2008) (noting that "soft law" signals the government's goals or interests).

best practices along the way.<sup>216</sup> Alongside the results of the 2022 thematic review on C&E risks of the banking sector, for example, the ECB published a compendium of good practices from a group of banks that had excelled in fulfilling supervisory expectations.<sup>217</sup>

Against this backdrop, supervisory guidance in the form of documents setting supervisory expectations followed by related diagnosis and feedback from the supervisor is a promising tool to bring about an iterative process of supervision of C&E risks.<sup>218</sup> Guidance gives the regulated industry fair warning as to how supervisors interpret the rules and intend to exercise their discretionary powers. Clear communication detailing the supervisors' expectations and articulating the reasons behind these expectations is paramount to the effectiveness and legitimacy of the supervisors' discretionary actions. Along these lines, the NGFS recommends that supervisors "set supervisory expectations to create transparency for financial institutions regarding the supervisors' understanding of a prudent approach to climate-related and environmental risks."<sup>219</sup>

Supervisory guidance also increases the predictability and uniformity of supervision and makes supervisors' actions more transparent not only to the regulated industry, but also to the public.<sup>220</sup> Setting supervisory expectations also gears institutions to better understand financial risks that can negatively impact themselves and their counterparties and helps them improve their internal risk-management processes.<sup>221</sup> Given that C&E risks materialize in a long-term horizon and data around them are still incomplete, supervisory expectations should explain how and to what extent this risk

---

<sup>216</sup> As defends Duke University's law professor James D. Cox, with respect to regulation and supervision over financial markets, iterative or incremental regulation works well when the statute or regulation announces a principle: "[...] whenever regulation is considered it is advisable to do so incrementally, with the level being dictated by the breadth and complexity of the area to be regulated. [...] Thus, agency initiatives to develop information regarding experiences of the regulated under a principle, safe harbour, or regulation obviously can inform future rulemaking." James D. Cox, *Iterative regulation of securities markets after Business Roundtable: A principles-based approach*, 78 *Law & Contemp. Probs.* p. 25, p. 45 (2015).

<sup>217</sup> See ECB, Good practices for climate-related and environmental risk management: Observations from the 2022 thematic review (November 2022), <https://www.bankingsupervision.europa.eu/ecb/pub/pdf/ssm.thematicreviewcercompendiumgoodpractices112022-b474fb8ed0.en.pdf>

<sup>218</sup> The Bank of England was a pioneer in setting supervisory expectations on the management of climate-related financial risks, directed to banks and insurers. Bank of England, Prudential Regulation Authority (PRA), *Supervisory Statement SS3/19: Enhancing banks' and insurers' approaches to managing the financial risks from climate change* (April 2019), <https://www.bankofengland.co.uk/-/media/boe/files/prudential-regulation/supervisory-statement/2019/ss319.pdf>.

<sup>219</sup> NGFS, *Guide for Supervisors: Integrating climate-related and environmental risks into prudential supervision* (May 2020).

<sup>220</sup> See David Zaring, *Best practices*, 81 *N.Y.U. L. Rev.* p. 294, pp. 299-300 (2006) (showing that regulating by issuing codes of "best practices" rather than by rule is an increasingly pervasive in administrative agencies and pointing out the advantages of best practices as a tool of harmonization). See also Coelho et al. (2023), p. 9 (warning that the principles-based nature of Pillar 2 can result in divergent supervisory practices within and across jurisdictions and defending further guidance on the implementation of Pillar 2 to provide structure and consistency in supervisory decision-making).

<sup>221</sup> "Leading by example" is also a kind of informal supervisory guidance. By adopting best practices in their own portfolio and actions, central banks and banking supervisory agencies signal to the regulated industry how relevant they consider C&E risks. Frank Elderson, *The role of supervisors and central banks in the climate crisis* (19 October 2021), Speech at the 31<sup>st</sup> Lisbon meeting between the central banks of Portuguese-speaking countries, <https://www.ecb.europa.eu/press/key/date/2021/html/ecb.sp211019-84d1b39bcb.en.html>.

category is being incorporated into financial supervision and what supervisors want to see from financial institutions.

The flexible and non-binding nature of supervisory guidance favours iteration, negotiation, dialogue, and a continuous exchange of information and expertise between supervisory authorities and financial institutions.<sup>222</sup> It allows supervisors to be more agile when responding to the rapid evolution of science and data related to climate change and other environmental phenomena relevant to the financial system's stability.<sup>223</sup> Its flexibility can also prevent supervisory lethargy or paralysis, as central banks and banking supervisory agencies might be more willing to use the full power of their discretion to issue general non-binding guidance than to mandate individualized actions. Moreover, as it is not binding, supervisory guidance may be exempt from the more stringent administrative-law requirements that apply to traditional rulemaking, dispensing, for example, with a preceding notice-and-comment period and cost-benefit analysis.<sup>224</sup>

In any case, the non-binding nature of supervisory instruments like supervisory guidance or guidelines must be clear for the regulated industry and the public. The goal should be to create a virtuous circle that leads to compliance without requiring stringent enforcement actions and not to dispense with otherwise relevant administrative requirements and conditions.

As noted by the NGFS, however, as supervisory guidance does not have the force and effect of law or regulation, it should not contain direct prescriptions, such as requiring the outright divestment of carbon-intensive sectors. Nor should it serve as an autonomous basis for enforcement actions.<sup>225</sup> Instead, its goal is to nudge – even if more forcefully when needed – the financial industry “to more fully appreciate the differentiated transition paths of different sectors and geographical regions and to proactively manage the risks.”<sup>226</sup> By supporting financial institutions' proactivity, supervisory guidance tends to diminish the need for enforcement actions, which can

---

<sup>222</sup> With the caveat that interaction between regulators or supervisors and the regulator industry always carries the risk of regulatory capture. See Masciandaro and Quintyn (2013) (n 19), pp. 301-302 (arguing the limited power of supervisory governance arrangements to eliminate each and every possibility of political, industry and self-capture).

<sup>223</sup> The Administrative Conference of the United States explains that general statements of policy, of which supervisory guidance is an example, are better than legislative rules for dealing with conditions of uncertainty. Administrative Conference of the United States (ACUS), *Administrative Conference Recommendation 2017-5* (14 December 2017), [https://www.acus.gov/sites/default/files/documents/Recommendation%202017-5%20%28Agency%20Guidance%20Through%20Policy%20Statements%29\\_2.pdf](https://www.acus.gov/sites/default/files/documents/Recommendation%202017-5%20%28Agency%20Guidance%20Through%20Policy%20Statements%29_2.pdf)

<sup>224</sup> See Yevgeny Shrager and David Arkush, *Looking over the horizon: The case for prioritizing climate-related risk supervision of banks* (June 2022), Roosevelt Institute; Public Citizen.

<sup>225</sup> See 12 CFR 262, clarifying the role of supervisory guidance provided by the Board of Governors of the Federal Reserve System, <https://www.federalregister.gov/documents/2021/04/08/2021-07146/role-of-supervisory-guidance>. See also ECB's declaration that guidance ERF management and disclosure guidance “is not binding for the institutions, but rather it serves as a basis for supervisory dialogue”, adding that “the ECB will discuss with institutions the ECB's expectations” set out in the guide. ECB, *Guide on climate-related and environmental risks*, <https://www.bankingsupervision.europa.eu/ecb/pub/pdf/ssm.202011finalguideonclimate-relatedandenvironmentalrisks%7E58213f6564.en.pdf>, p. 3.

<sup>226</sup> NGFS (May 2022) (n 17), p. 6.

be slow, cumbersome, and costly for regulators and financial institutions alike, not to mention prone to provoke moral hazard, when perceived as too lenient.<sup>227</sup>

On the other hand, well-articulated supervisory guidance can precede – without being the sole foundation of – enforcement actions.<sup>228</sup> Enforcement actions, if treated as a last-resort supervisory mechanism, gain in legitimacy when they follow the issuance of supervisory expectations because they indicate the supervisor's likely course of action and minimize the probability of adjudication that violates reliance interests.<sup>229</sup> Under this framework, enforcement strategies are arranged in a pyramid: more cooperative strategies are at the base of the pyramid, and thus used initially, and these strategies escalate to progressively more punitive strategies until the supervisor reaches the most severe sanctions, sitting at the apex of the pyramid, although some extreme situations might call for taking enforcement actions right away, requiring supervisors to go straight to the apex of the pyramid.<sup>230</sup>

## 6 Supervising C&E risks: enhancing supervisory guidance with scenario analysis and stress testing

To enhance its effectiveness, supervisory guidance should be followed by diagnosis and feedback regarding the regulated industry's adherence to the supervisory expectations, in the form of 'dear CEO' letters, individualized feedback letters, progress reports, or thematic reviews.<sup>231</sup> Diagnosis of how financial institutions are dealing with C&E risks is in part informed by scenario analysis and stress testing. Both these tools enable a forward-looking snapshot of the financial institutions' exposure to

---

<sup>227</sup> See ACUS, arguing that “compared with adjudication or enforcement, policy statements can make agency decision making faster and less costly, saving time and resources for the agency and the regulated public.” See ACUS (2017) (n 86), p. 2.

<sup>228</sup> The ECB, for example, has imposed a remediation timeline for banks to comply with supervisory expectations for sound management of risks: by the end of 2024, banks should align themselves with supervisory expectations. Non-compliance with the timeline will affect the banks' scores and, consequently, capital requirements under Pillar 2. Elderson (2023), *Closing the gaps*; ECB, *Walking the talk: Banks gearing up to manage risks from climate change and environmental degradation* (November 2022), Results of the 2022 thematic review on climate-related and environmental risks, <https://www.bankingsupervision.europa.eu/ecb/pub/pdf/ssm.thematicreviewcerreport112022-2eb322a79c.en.pdf>

<sup>229</sup> “Taking the pains to articulate the agency's expectations, even if only through soft law tools like staff guidance and no action letters, are more likely to set the stage for more broadly accepted enforcement actions with high policy throughput.” (Brummer et al., 2023, *Regulation by enforcement*).

<sup>230</sup> See This framework of a “regulatory pyramid” is proposed by a theoretical model of responsive regulation, with the expectation that the regulated industry will comply with the rules as a result of internalization and institutionalization of compliance norms, informal pressure, and the threat of being punished with an onerous sanction. John Braithwaite, *The essence of responsive regulation*, 44 U.B.C. L. Rev. p. 475 (2011); Christine Parker, *The compliance trap: The moral message in responsive regulatory enforcement*, 40 Law & Soc'y Rev. p. 591, p. 592 (2006).

<sup>231</sup> See Bank of England, Dear CEO Letter (July 2020), <https://www.bankofengland.co.uk/-/media/boe/files/prudential-regulation/letter/2020/managing-the-financial-risks-from-climate-change.pdf>.

C&E risks, which is particularly relevant considering how little historical data and patterns exist that can contribute to the present assessment of C&E risks.<sup>232</sup>

The ECB's 2022 climate stress test, for instance, assessed the banks' alignment with the ECB's supervisory expectations contained in the Guide on climate-related and environmental risks.<sup>233</sup> The stress test complemented the assessment of alignment with the supervisory expectations laid out in the 2022 thematic review of banks' climate-related and environmental risk management practices, a report on banks' self-assessment of their practices requested by the ECB in 2021, a report on institutions' disclosure of C&E risks, and other periodic assessments.<sup>234</sup> In the United States (US), the Office of the Comptroller of the Currency (OCC), the Federal Deposit Insurance Corporation (FDIC), and the Board of Governors of the Federal Reserve System have proposed similar guidance for financial institutions under their jurisdiction with over USD 100 billion in total consolidated assets.<sup>235</sup> The Board will complement supervisory guidance with an exercise of climate-scenario analysis of a relatively narrower scope than other central banks' exercises: the Federal Reserve System's

---

<sup>232</sup> See Bank of England, PRA, *Climate-related financial risk management and the role of capital requirements: Climate Change Adaptation Report 2021* (28 October 2021), Executive summary, viii, <https://www.bankofengland.co.uk/-/media/boe/files/prudential-regulation/publication/2021/october/climate-change-adaptation-report-2021.pdf> (pointing out that climate-related risks "will crystallise over short, medium and long time horizons, and will likely grow over time," therefore they might "profoundly alter historical trends"). The NGFS defines stress testing as "a specific subset of scenario analysis, typically used to evaluate a financial institution's near-term resiliency to economic shocks, often through a capital adequacy target." NGFS, p. 40, [https://www.ngfs.net/sites/default/files/progress\\_report\\_on\\_the\\_guide\\_for\\_supervisors\\_0.pdf](https://www.ngfs.net/sites/default/files/progress_report_on_the_guide_for_supervisors_0.pdf). The Federal Reserve System has also differentiated stress tests from scenario analysis when announcing its Pilot Climate Scenario Analysis (CSA) Exercise: "Climate scenario analysis is distinct and separate from bank stress tests. The Board's stress tests are designed to assess whether large banks have enough capital to continue lending to households and businesses during a severe recession. The pilot climate scenario analysis exercise, on the other hand, is exploratory in nature and does not have capital consequences." Board, Press release (17 January 2023), <https://www.federalreserve.gov/newsevents/pressreleases/other20230117a.htm>. Similarly, the Bank of England has stated that the results of its 2021 Climate Biennial Exploratory Scenario (CBES) will not be used to set capital requirements related to climate risk. Bank of England, *Results of the 2021 Climate Biennial Exploratory Scenario* (CBES), chapter 6.2, <https://www.bankofengland.co.uk/-/media/boe/files/stress-testing/2022/results-of-the-2021-cbes.pdf>. The European Central Bank (ECB) calls its exercise a stress test—the 2022 ECB climate risk stress test—although it will not have direct capital implications for the supervised institutions. ECB, 2022 Climate risk stress test (July 2022), p. 4, [https://www.bankingsupervision.europa.eu/ecb/pub/pdf/ssm.climate\\_stress\\_test\\_report.20220708-2e3cc0999f.en.pdf](https://www.bankingsupervision.europa.eu/ecb/pub/pdf/ssm.climate_stress_test_report.20220708-2e3cc0999f.en.pdf)

<sup>233</sup> ECB, 2022 *Climate risk stress test* (July 2022), p. 3, [https://www.bankingsupervision.europa.eu/ecb/pub/pdf/ssm.climate\\_stress\\_test\\_report.20220708-2e3cc0999f.en.pdf](https://www.bankingsupervision.europa.eu/ecb/pub/pdf/ssm.climate_stress_test_report.20220708-2e3cc0999f.en.pdf). The "Guide on climate-related and environmental risks" describes how the ECB expects supervised institutions to consider climate-related and environmental risks and "serves as a basis for supervisory dialogue." ECB, *Guide on climate-related and environmental risks: Supervisory expectations relating to risk management and disclosure* (November 2020), p. 3, <https://www.bankingsupervision.europa.eu/ecb/pub/pdf/ssm.202011finalguideonclimate-relatedandenvironmentalrisks-58213f6564.en.pdf>.

<sup>234</sup> In early 2021, the ECB has asked banks to conduct a self-assessment of their steps to meet the supervisory expectations outlined in the 2020 guide and to formulate action plans on that basis. Later in 2021, the ECB issued a report on the supervisory review of the banks' practices towards C&E risks. ECB, *The state of climate and environmental risk management in the banking sector: Report on the supervisory review of banks' approaches to manage climate and environmental risks* (November 2021), <https://www.bankingsupervision.europa.eu/ecb/pub/pdf/ssm.202111guideonclimate-relatedandenvironmentalrisks%7E4b25454055.en.pdf>. In November 2021, the ECB issued a report containing snapshot of the state of disclosures of C&E risks in 2020. The report provides a baseline against which alignment with supervisory expectations could be measured. ECB, *ECB report on institutions' climate-related and environmental risk disclosures* (November 2020), <https://www.bankingsupervision.europa.eu/ecb/pub/pdf/ssm.ecbreportinstitutionsclimaterelatedenvironmentalriskdisclosures202011-e8e2ad20f6.en.pdf>

<sup>235</sup> See Board, *Proposed Risk Management Guidance on Climate-Related Financial Risks for Large Financial Institutions* (23 November 2022), Note, <https://www.federalreserve.gov/newsevents/pressreleases/files/other20221202b2.pdf>.

exercise comprehends only six major banks and assesses transition risks over up to 10 years.<sup>236</sup> In 2021, the Bank of England launched its first Climate Biennial Exploratory Scenario (CBES), which followed supervisory expectations set in 2019.<sup>237</sup>

Scenario analysis and stress testing also contribute to a better understanding of the size and characteristics of physical and transition risks stemming from climate change and environmental harm, further enhancing the iterative nature of supervisory guidance.<sup>238</sup> By providing regulators, supervisors, and the regulated industry with a comprehensive diagnosis, they support the development of more adequate and tailor-made policies as well as the improvement of internal risk management structures and the adjustment of strategic business decisions and governance structures.<sup>239</sup> Scenario analysis focused on C&E risks is also expected to inform the dialogue between supervisors and the supervised industry and help them to assess more easily whether financial institutions are meeting supervisory expectations.<sup>240</sup>

By using scenarios that apply simulated stressors (like exogenous shocks and adverse market conditions) to individual institutions and the financial system as a whole, stress tests can take to the extreme the diagnosis of supervisory guidance's adequacy and effectiveness.<sup>241</sup> The aim of stress tests is to assess how resilient the institutions and the system are by projecting the consequences of an adverse environment. In the realm of C&E risks, designing the scenarios that will serve as baseline for stress tests is a significant challenge, given the uncertainty inherent in climate change and other environmental phenomena.<sup>242</sup> But because stress tests can be designed based on scenarios that consider a longer time frame than other risk management processes do, they can be useful to steer the regulated industry to seriously consider a future

---

<sup>236</sup> See Board, *Federal Reserve Board announces that six of the nation's largest banks will participate in a pilot climate scenario analysis exercise designed to enhance the ability of supervisors and firms to measure and manage climate-related financial risks* (29 September 2022), Press Release, <https://www.federalreserve.gov/newsevents/pressreleases/other20220929a.htm>

<sup>237</sup> See Bank of England, *Results of the 2021 Climate Biennial Exploratory Scenario (CBES)* (24 May 2022), <https://www.bankofengland.co.uk/stress-testing/2022/results-of-the-2021-climate-biennial-exploratory-scenario>; Bank of England, *Supervisory Statement 3/19: Enhancing banks' and insurers' approaches to managing the financial risks from climate change* (15 April 2019), <https://www.bankofengland.co.uk/prudential-regulation/publication/2019/enhancing-banks-and-insurers-approaches-to-managing-the-financial-risks-from-climate-change-ss>

<sup>238</sup> See NGFS, *Progress report on the Guide for Supervisors* (October 2021), Technical document, p. 24, [https://www.ngfs.net/sites/default/files/progress\\_report\\_on\\_the\\_guide\\_for\\_supervisors\\_0.pdf](https://www.ngfs.net/sites/default/files/progress_report_on_the_guide_for_supervisors_0.pdf). This article considers the terms "scenario analysis" and "stress testing" synonyms and uses them interchangeably, the nomenclature varies across jurisdictions. Patrizia Baudino and Jean-Philippe Svoronos (n 6), p. 2.

<sup>239</sup> The BCBS has recommended that banks use stress tests to inform "risk appetite and limits, financial and capital planning, liquidity and funding risk assessment, contingency planning and recovery and resolution planning." BCBS, *Stress testing principles* (October 2018), p. 5, <https://www.bis.org/bcbst/publ/d450.pdf>. See also Dan Awrey and Kathryn Judge, *Why Financial Regulation Keeps Falling Short*, 61 B.C. L. Rev. p. 2295, pp. 2347-2348 (2020) (noting the role of experimentalism and responsive or adaptive regulation for regulating efficiently the financial system, given its uncertainty, dynamism, and complexity).

<sup>240</sup> See Bank of England, *Results of the 2021 Climate Biennial Exploratory Scenario (CBES)*, chapter 6.2, <https://www.bankofengland.co.uk/-/media/boe/files/stress-testing/2022/results-of-the-2021-cbes.pdf>

<sup>241</sup> According to the TCFD, scenarios are intended to "highlight central elements of a possible future and to draw attention to the key factors that will drive future developments". Scenario analysis, therefore, is "a tool to enhance critical strategic thinking". TCFD, *The use of scenario analysis in disclosure of climate-related risks and opportunities*, <https://www.tcfhub.org/scenario-analysis/>.

<sup>242</sup> Deficiencies and unavailability of transition plans, for example, are often cited as limitations to gathering forward-looking information that will inform the scenarios. FSB and NGFS, *Climate scenario analysis by jurisdictions: Initial findings and lessons* (15 November 2022), p. 27, [https://www.ngfs.net/sites/default/files/medias/documents/climate\\_scenario\\_analysis\\_by\\_jurisdictions\\_initial\\_findings\\_and\\_lessons.pdf](https://www.ngfs.net/sites/default/files/medias/documents/climate_scenario_analysis_by_jurisdictions_initial_findings_and_lessons.pdf).

impacted by climate change and environmental loss, rather than being limited to the typical short-term risk assessment frame.<sup>243</sup>

Finally, the disclosure of credible stress tests' results can promote market discipline and influence private capital allocation, which in turn could support the transition to a green low-carbon economy. Transparency can compel the private sector to establish a more realistic price for C&E risks, contributing to correct a prevailing market failure.<sup>244</sup> It should, however, be balanced against the confidentiality of sensitive supervisory information to avoid that unfiltered disclosures lead to financial instability.<sup>245</sup>

## 7 Conclusion

The latest synthesis report by the Intergovernmental Panel on Climate Change (IPCC) warns that, in the near term, the risk of global warming reaching a 1.5 °C rise since pre-industrial times is “more likely than not.” According to the United Nation IPCC’s scientists, this risk is greater than before, making government efforts in mitigation and adaptation even more urgent – the world must cut global emissions by over 40 % by 2030 to preserve the chances of limiting warming to 1.5 °C.<sup>246</sup> Moreover, scientists from the World Meteorological Organization (WMO) have identified a two-thirds chance that the temperature in one of the next five years will be 1.5 °C above pre-industrial levels, due to human-caused global warming and natural phenomena like El Niño.<sup>247</sup> Nevertheless, global emissions continue their rising trend. Accelerated global warming translates into heightened climate risks, both in physical and transition form, and consequently into financial risks since financial intermediation touches all but every sector of the real economy. The same can be said about other environmental risks, which are accentuated by climate change and can aggravate global warming.<sup>248</sup>

The climate and environmental crisis is real, and we are already seeing and feeling its damaging effects.<sup>249</sup> What then can central banks and banking supervisory agencies

---

<sup>243</sup> See Jens van't Klooster, Reflections on the 2022 Nobel Memorial Prize awarded to Ben Bernanke, Douglas Diamond, and Philip Dybvig, 16(1) *Erasmus J. Phil. and Econ. aa* (Summer 2023), <https://doi.org/10.23941/ejpe.v16i1.745>

<sup>244</sup> See Isabel Schnabel, *When markets fail—the need for collective action in tackling climate change* (28 September 2020), [https://www.ecb.europa.eu/press/key/date/2020/html/ecb.sp200928\\_1~268b0b672f.en.html](https://www.ecb.europa.eu/press/key/date/2020/html/ecb.sp200928_1~268b0b672f.en.html)

<sup>245</sup> See also Itay Goldstein and Yaron Leitner, *Stress tests disclosures: theory, practice, and new perspectives*, chapter 11 in *Handbook of Financial Stress Testing* (February 2022), ed. J. Doyne Farmer et al., pp. 208-223, <https://doi-org.proxy.lib.duke.edu/10.1017/9781108903011> (warning that commitment to full disclosure may diminish the informational value of stress tests and urging regulators to consider the downsides of publishing stress test results and the models used to conduct stress tests).

<sup>246</sup> See Intergovernmental Panel on Climate Change (IPCC), *IPCC Press Release* (20 March 2023), [IPCC\\_AR6\\_SYR\\_PressRelease\\_en.pdf](https://www.ipcc.ch/press/2023/03/20/ipcc_ar6_syr_pressrelease_en.pdf).

<sup>247</sup> See World Meteorological Organization (WMO), *WMO Global Annual to Decadal Climate Update* (2023), Target years: 2023 and 2023-2027, p. 2, [https://library.wmo.int/index.php?lvl=notice\\_display&id=22272](https://library.wmo.int/index.php?lvl=notice_display&id=22272)

<sup>248</sup> See World Economic Forum (WEF), *The Global Risks Report 2023* (2023), 18<sup>th</sup> Edition, Insight Report, [https://www3.weforum.org/docs/WEF\\_Global\\_Risks\\_Report\\_2023.pdf](https://www3.weforum.org/docs/WEF_Global_Risks_Report_2023.pdf).

<sup>249</sup> See Ilimi Granoff, *The tragedy of the financial horizon is closer than you think* (4 May 2023), Climate Law Blog, [https://blogs.law.columbia.edu/climatechange/2023/05/04/the-tragedy-on-the-financial-horizon-is-closer-than-you-think/?mc\\_cid=18382a588a&mc\\_eid=7cf1efd02d](https://blogs.law.columbia.edu/climatechange/2023/05/04/the-tragedy-on-the-financial-horizon-is-closer-than-you-think/?mc_cid=18382a588a&mc_eid=7cf1efd02d) (arguing that focus on the very long-term effects of climate change has led to corporate inaction and pointing out the mismatch between the short-termism of the market and the long-termism of climate modelling).

do in response? Directly interfering with capital allocation to fight this crisis is treacherous. Central banks and banking supervisory agencies do not have the tools to do it successfully and, in many cases, nor the legal mandate to do it legitimately.<sup>250</sup> Inertia, on the other hand, would mean coming short of the responsibilities regarding financial stability with which society, through its elected representatives, has entrusted central banks and banking supervisory agencies.

So, to fulfil their existing legal duties, notably those related to the stability of the financial system, central banks and banking supervisory agencies must reinvent themselves. They must contribute to the ‘all-hands-on-deck’ effort the world needs to make now.<sup>251</sup> They must strive to build capacity and expertise to better understand the C&E risks that threaten the financial system, directly or indirectly. They must incorporate these risks into their regulatory and supervisory frameworks. And they must require that financial institutions take C&E risks seriously and react accordingly to the existing threats.

Doing so entails revisiting legal and regulatory provisions and adapting supervisory policies and instruments to make them capable of coping with the radical uncertainty, complexity, and long-term effects inherent in this category of risks. To that end, the concept of principles-based regulation can be adapted and improved to enhance the regulatory treatment of C&E risks. Principles-based regulation and open-ended rules, however, do not mean light-touch regulation and toothless supervision.<sup>252</sup> Supervision should be firm and timely, and it should include enforcement actions when rules are violated.<sup>253</sup> In the aftermath of the 2023 bank turmoil in the US, just to keep with a recent example, the Federal Reserve System, the FDIC, and the US Government

---

<sup>250</sup> See Frank Elderson, *Closing gaps to bend the trend: embedding the flow of finance in the transition* (5 May 2023), <https://www.ecb.europa.eu/press/key/date/2023/html/ecb.sp230505-06e499fce7.en.html> (Speech, stating that it is not the role of the ECB’s Supervisory Board to determine to whom banks should lend). See also Martin Oehmke and Marcus Opp, *Green Capital Requirements* (25 February 2023), [https://www.bankingsupervision.europa.eu/press/conferences/shared/pdf/20230502\\_research\\_conference/Oehmke\\_paper.pdf](https://www.bankingsupervision.europa.eu/press/conferences/shared/pdf/20230502_research_conference/Oehmke_paper.pdf) (noting that higher capital requirements on loans affected by C&E risks may have the counter-effect of reducing clean lending by constraining the bank’s balance-sheet space, even though they might make the institution and the system safer from a financial stability point-of-view).

<sup>251</sup> See Sarah Bloom Raskin, *Changing the climate of financial Regulation*, Project Syndicate (10 September 2021), <https://www.project-syndicate.org/magazine/us-financial-regulators-climate-change-by-sarah-bloom-raskin-2021-09> (urging financial regulators in the United States to reimagine their policies and processes, their mandates being broad enough to encompass climate-related risks).

<sup>252</sup> See Tarbert (n 47), p. 6 (2019-2020).

<sup>253</sup> See Pablo Herández de Cos, *Banking starts with banks: Initial reflections on recent market stress episodes* (12 April 2023), <https://www.bis.org/speeches/sp230412.pdf> (urging support for “the ability of a supervisor to exercise its judgment and tell a bank that its leverage or maturity transformation is too elevated, or that its business model is unsustainable, or that it needs to adopt prompt and substantive measures to shore up risk management and governance failings.”).



Accountability Office (GAO) have all issued reports acknowledging that hesitant supervision contributed to the failure of Silicon Valley Bank and Signature Bank.<sup>254</sup>

That is why this chapter proposes to couple open-ended rules with iterative supervision, a supervisory strategy that involves a candid and straightforward relationship between supervisors and supervised institutions. This relationship can thus contribute to the effective incorporation of C&E risks into the risk assessment and management performed by financial institutions, with the ultimate objective of protecting financial stability.<sup>255</sup> However, it should be clear that central banks and banking supervisory agencies will not be tolerant or lenient with uncooperative institutions and repeat offenders. Forceful supervisory guidance followed by diagnosis and feedback that can clearly demonstrate if adherence is happening and progress is being made is much needed. And if this toolkit shows that the expected results are not being achieved, the evidence it creates must serve as a robust factual basis to substantiate enforcement actions against violators of binding provisions.

This kind of collaborative relationship traditionally relies on the confidentiality of supervisory information. However, central banks and banking supervisory agencies' accountability to the public must be proportionate to the wideness of discretion they have in order to achieve the broad objectives of protecting the safety and soundness of institutions and systemic financial stability.<sup>256</sup> In other words, more discretion must be accompanied by more accountability.<sup>257</sup> A high level of supervisory accountability, in turn, requires a high degree of transparency regarding supervisory activities and

---

<sup>254</sup> See Board of Governors of the Federal Reserve System, *Review of the Federal Reserve's Supervision and Regulation of Silicon Valley Bank* (April 2023), <https://www.federalreserve.gov/publications/files/svb-review-20230428.pdf>; *Federal Deposit Insurance Corporation (FDIC), FDIC's Supervision of Signature Bank* (28 April 2023), <https://www.fdic.gov/news/press-releases/2023/pr23033a.pdf>; U.S. Government Accountability Office (GAO), *Preliminary Review of Agency Actions Related to March 2023 Bank Failures* (April 2023), p. 27, <https://www.gao.gov/assets/gao-23-106736.pdf> (expressing concerns with the escalation of supervisory actions and reinforcing the recommendation that regulators add noncapital triggers to their framework for prompt corrective action). See also European Court of Auditors (ECA), *EU Supervision of Bank's Credit Risk* (2023), Special Report 12/2023, [https://www.eca.europa.eu/ECAPublications/SR-2023-12/SR-2023-12\\_EN.pdf](https://www.eca.europa.eu/ECAPublications/SR-2023-12/SR-2023-12_EN.pdf) (calling supervisors to escalate supervisory measures when there are problems); François Villeroy de Galhau, *Presentation of the Annual Report of the "Autorité de contrôle prudentiel et de résolution (ACPR)" for 2022* (31 May 2023), <https://www.bis.org/review/r230601c.pdf> (pointing out that Credit Suisse has failed despite meeting Basel III requirements and that regulation is only effective if supervision is efficient).

<sup>255</sup> See Hockett (2015) (n 23), p. 236 ("A financial regulator might, for example, find it much easier to acquire necessary information from a regulated entity insofar as it can credibly commit to that entity not to share the information with its competitors. A transparency requirement pursuant to which the regulator is required to make public such information can accordingly compromise its mission in a serious way.")

<sup>256</sup> See Peter Conti-Brown, *The curse of confidential supervisory information* (20 December 2019), Brookings Institution, <https://www.brookings.edu/research/the-curse-of-confidential-supervisory-information/>

<sup>257</sup> See Masciandaro and Quintyn (2013) (n 19), pp. 292-293 (highlighting the great range of contingencies that occur in regulation and supervision and defending a detailed structure of accountability arrangements for supervisors, including transparency and agency-integrity mechanisms, to complement and buttress supervisors' independence).

disclosure of supervisory documents.<sup>258</sup> So, within the limitations imposed by concerns with financial stability and the protection of proprietary information that may affect an institution's competitive position, a high level of transparency regarding the financial supervision of C&E risks is desirable.<sup>259</sup> Future research – and practice – will hopefully illuminate the central banks' and supervisors' difficult task of finding the right balance between confidentiality and transparency.

---

<sup>258</sup> See Ignazio Angeloni, *Transparency and banking supervision* (27 January 2015), European Central Bank (ECB), <https://www.bankingsupervision.europa.eu/press/speeches/date/2015/html/se150127.en.html>. See Core Principle for independent supervisors (BCBS)—“transparent processes”. See also Randall K. Quarles, *Spontaneity and order: Transparency, accountability, and fairness in bank supervision* (17 January 2020), <https://www.federalreserve.gov/newsevents/speech/quarles20200117a.htm> (positing that the confidential nature of prudential supervision may trump the functioning of accountability mechanisms). See also Board, Review of the Federal Reserve's Supervision and Regulation of Silicon Valley Bank (April 2023), Cover Letter by Michael Barr, Vice Chair for Supervision, vii (invoking the public interest to release supervisory material that is typically treated as confidential supervisory information).

<sup>259</sup> Publicizing results of climate stress tests and financial institutions adequacy to supervisory expectations, as did the ECB in the 2022 thematic review, is a good example of how transparency can potentialize the effects of central banks and banking supervisory agencies' actions with relation to C&E risks. Note also that, according to the European Court of Auditors (ECA), “the ECB's publications on supervision show that it has been moving towards more transparency (for example in 2020 publishing for the first time the pillar 2 requirements for each bank).” The ECA adds that “this enhances market discipline, the third pillar of the Basel framework for supervision as well as its [the ECB's] own accountability.” European Court of Auditors (ECA), *EU supervision of banks' credit risk* (2023), Special Report, p. 14, [https://www.eca.europa.eu/ECAPublications/SR-2023-12/SR-2023-12\\_EN.pdf](https://www.eca.europa.eu/ECAPublications/SR-2023-12/SR-2023-12_EN.pdf)

# The incorporation of environmental considerations in the regulation and supervision of prudential risks

Veerle Colaert\*

Since the European Commission adopted its Sustainable Finance Action Plan (Action Plan) in March 2018, the prudential rulebook has substantially changed. This contribution evaluates the impact of those changes on the nature of prudential regulation by examining (i) whether sustainable finance should be considered as an autonomous objective of prudential regulation – necessary to explain certain prudential rules, and (ii) how this objective should stand in relation to traditional objectives of prudential regulation, namely stability, market integrity and consumer protection.

On the basis of an assessment of the amendments to the prudential framework for credit institutions adopted pursuant to the Action Plan, we conclude that sustainable finance is not an autonomous objective of prudential regulation yet, but has the potential to become one in the future. In case of a conflict between the sustainable finance objective and the traditional objectives, we argue that the sustainable finance objective should give way to the traditional objectives of financial regulation. A green supporting factor, which would impair stability, should therefore be avoided; a brown penalty would not directly impair stability, but may have indirect perverse effects which require careful assessment.

## 1 Introduction

Until recently, no legal scholar researching financial regulation would have disputed that the main objectives of financial regulation are ensuring stability, market integrity and consumer protection, in addition to more general objectives of economic policy such as promoting efficiency, competition, innovation, and ultimately economic growth. They would typically agree that, in case of a conflict between those objectives, the stability-objective should, in principle, prevail, especially in the field of prudential regulation.

Since the European Commission's Action Plan of March 2018, however, sustainable finance has dominated the European Union (EU) legislator's agenda on financial regulation. To implement the Action Plan, myriad new regulations and amendments to existing regulatory frameworks have seen the light of day. The pace and amplitude of

---

\* Financial Law Professor at KU Leuven University; Chair of the Securities and Markets Stakeholder Group; Member of the Belgian Resolution Board. This contribution is partly based on a more general contribution recently published in the *Common Market Law Review*. See Colaert, V. (2022) "The Changing Nature of Financial Regulation: Sustainable Finance as a New Policy Objective" *CML Rev*, No 59, pp. 1669-1710.

these regulatory changes, weaving sustainable finance into each and every facet of the EU financial rulebook, including in the prudential framework for credit institutions, beg the following questions. First, we raise the question whether sustainable finance should be considered as a new autonomous objective of prudential regulation. We consider an objective as ‘autonomous’ if without it, certain rules of financial regulation cannot be explained. If it is not indispensable to explain why certain rules have been put in place, it would merely be a supporting objective, which may help in refining and giving shape to measures addressing other, autonomous objectives. Regardless of whether or not sustainable finance is (yet) a new autonomous objective, it is in any case clearly mentioned as an objective in many policy documents. It raises the second question, of how this new objective should stand in relation to the traditional objectives of prudential regulation, i.e., should, in case of a conflict between objectives, a hierarchy be respected between the different objectives of prudential regulation.

By way of background, we first give an overview of the development of sustainable finance in the EU (section 2). Then, we discuss how Environmental, Social and Governance (ESG) considerations have been incorporated in the regulation and supervision of prudential risks, evaluating whether those new measures can be explained on the basis of the traditional objectives of prudential regulation or not (section 3). To that end, we establish whether and to what extent the new measures taken under the banner of sustainable finance can be explained as a refinement of traditional objectives. Only if these traditional objectives are insufficient to explain certain new measures, sustainable finance can be qualified as a new, autonomously guiding objective of financial regulation. Subsequently, we discuss the relationship between the stability and the sustainability objectives (section 4). Conclusions follow (section 5).

## 2 Sustainable finance in the EU

### 2.1 Brief history

Sustainability is a constitutionally enshrined objective of the EU. Already in 1992, the Treaty of Maastricht established that one of the objectives of the Union was to “promote economic and social progress which is balanced and sustainable”.<sup>260</sup> The current version of the Treaty on European Union (TEU) is even more explicit in its sustainability aims, stating that the EU shall “work for the sustainable development of Europe based on balanced economic growth and price stability, a highly competitive social market economy, aiming at full employment and social progress, and a high level of protection and improvement of the quality of the environment.”<sup>261</sup> Article 11 of the Treaty on the Functioning of the European Union (TFEU) furthermore states that “environmental protection requirements must be integrated into the definition and implementation of the Union’s policies and activities, in particular with a view to

---

<sup>260</sup> Article B of the original Treaty on European Union [1992] OJ C191/1 (Maastricht Treaty).

<sup>261</sup> Article 3(3) TEU. See also Article 3(5).

promoting sustainable development.<sup>262</sup> It is not surprising then that the EU took steps to integrate sustainability in its policy for the financial industry. Considering the early mention of these objectives in the Treaties, however, the integration of sustainability into the EU financial rulebook took some time.

At a global level, the idea that the financial sector can make a substantial contribution to the transition to a sustainable economy dates back to 1992, when the Rio Summit resulted in the “UN Environment Programme Statement by Banks on the Environment and Sustainable Development”.<sup>263</sup> At about the same time the European Commission indicated in its fifth climate action plan that financial institutions, which assume the risk of companies and plants, can exercise considerable influence over investment and management decisions and that this could be brought into play to benefit the environment.<sup>264</sup> The European Commission has developed these ideas in its subsequent climate action plans<sup>265</sup> and in a parallel plan to stimulate corporate social responsibility.<sup>266</sup>

The establishment of the UN sustainable development objectives and the Paris Agreement in 2015 gave momentum to the idea that sustainable finance should play an important part in the pursuit of a more sustainable society.<sup>267</sup> In 2016, the European Commission appointed an expert group (High Level Expert Group or HLEG) to draft a blueprint for reform. The group concluded that a comprehensive review of financial regulation was necessary to achieve the ambitions set out in its report.<sup>268</sup> On that basis the European Commission adopted its eighth climate action plan, entirely dedicated to sustainable finance, on 8 March 2018 (Sustainable Finance Action Plan).<sup>269</sup> The EU Green Deal of December 2019,<sup>270</sup> the Green Deal investment plan

---

<sup>262</sup> See also Articles 191-193 TFEU; Article 37 of the Charter of Fundamental Rights of the European Union [2000] OJ C364/1.

<sup>263</sup> UN Environment Programme, “History of the Statement”, <https://www.unepfi.org/about/unep-fi-statement/history-of-the-statement/>

<sup>264</sup> Commission (1993), “Towards Sustainability. A European Community Programme of policy and action in relation to the environment and sustainable development”, p. 58, <https://op.europa.eu/en/publication-detail/-/publication/c5e82ded-f31e-4eed-ae4b-8f7f1e1b4fc3>.

<sup>265</sup> A revision of the action plan in 1998 encouraged providers of financial services to integrate environmental considerations in their operations (see Article 5(2)(i) of Decision No 2179/98/EC of the European Parliament and of the Council of 24 September 1998 on the review of the European Community programme of policy and action in relation to the environment and sustainable development ‘Towards sustainability’ (OJ L 275, 10.10.1998, p. 1). The sixth climate action plan of 2002 also stressed the necessity of the financial sector integrating environmental considerations, for example in financial reports (see Article 3(7) of Decision No 1600/2002/EC of the European Parliament and of the Council of 22 July 2002 laying down the Sixth Community Environment Action Programme (OJ L 242, 10.9.2002, p. 1). See also recital 77 in conjunction with 84, b of the seventh action plan (Decision No 1386/2013/EU of the European Parliament and of the Council of 20 November 2013 on a General Union Environment Action Programme to 2020 ‘Living well, within the limits of our planet’ (OJ L 354, 28.12.2013, p. 171).

<sup>266</sup> European Commission (2011), “A renewed EU strategy 2011-2014 for Corporate Social Responsibility” (COM(2011) 681 final).

<sup>267</sup> Article 2(1)(c) of the Paris Agreement mentions its objective to strengthen the global response to the threat of climate change, including by “making finance flows consistent with a pathway towards low greenhouse gas emissions and climate-resilient development” (United Nations, “Paris Agreement” (12 December 2015) [https://unfccc.int/sites/default/files/english\\_paris\\_agreement.pdf](https://unfccc.int/sites/default/files/english_paris_agreement.pdf)).

<sup>268</sup> High-Level Expert Group on Sustainable Finance (2018), “Financing a Sustainable European Economy - Final Report”, p. 6 [https://ec.europa.eu/info/sites/info/files/180131-sustainable-finance-final-report\\_en.pdf](https://ec.europa.eu/info/sites/info/files/180131-sustainable-finance-final-report_en.pdf).

<sup>269</sup> European Commission (2018), “Action Plan: Financing Sustainable Growth” (COM(2018) 97 final).

<sup>270</sup> European Commission (2019), “The European Green Deal” (COM(2019) 640 final).

of January 2020<sup>271</sup> and the Strategy for financing the transition to a sustainable economy of July 2021<sup>272</sup> further emphasised and developed the EU's sustainable finance ambitions.<sup>273</sup>

Since the publication of the Action Plan, a wave of (re-)regulation has hit the financial sector. New regulations have been adopted and nearly all existing financial directives and regulations have been or are being reviewed in order to weave the European Commission's sustainable finance objectives into the financial rulebook. In addition, the European Central Bank (ECB) and the European supervisory authorities have issued or amended certain guidelines, urging financial institutions to already take sustainability into account pending review of the actual legislation. As a result, in merely a few years' time the entire European financial rulebook will have been rewritten in the light of the European sustainable finance objectives.

## 2.2 Sustainable finance as a 'cluster-objective'

Under the 'sustainable finance'-banner, the Financial Services Action Plan, in fact, clusters three sub-objectives. In this sub-section, we analyse each of those sub-objectives in order to determine whether they are worded as supporting one or more of the traditional objectives of financial regulation, or as an autonomous objective.

The first sub-objective is "reorienting capital flows towards sustainable investment in order to achieve sustainable and inclusive growth". This sub-objective is very much worded as an autonomous objective.

The second sub-objective of sustainable finance is "managing financial risks stemming from climate change, resource depletion, environmental degradation and social issues". When financial institutions integrate financial risks stemming from ESG-issues into their investment decisions, they will make better estimates of the financial risks involved, which should, in turn, improve bank stability. This sub-objective of sustainable finance therefore mainly seems to support a more accurate implementation of the financial stability objective.

The third sub-objective is fostering "transparency and long-termism in financial and economic activity". This sub-objective can be broken down in two parts, transparency and long-termism. From a law and economics perspective, fostering transparency is central to the elimination of information asymmetries and is typically considered as a means to further consumer protection and/or market integrity by promoting market

---

<sup>271</sup> European Commission (2020), "Sustainable Europe Investment Plan - European Green Deal Investment Plan" (COM(2020) 21 final).

<sup>272</sup> European Commission, "Strategy for financing the transition to a sustainable economy" (COM(2021) 390 final), pp. 2 and 5.

<sup>273</sup> See for an in-depth discussion of the rationale and ways of functioning of the European Green Deal Project and its relationship with existing international initiatives: Chiti, E. (2022), "Managing the Ecological Transition of the EU: The European Green Deal as a Regulatory Process" *CMLRev*, No 59, pp. 19-48. The author frames the EU Green Deal as an attempt to move from an EU integration process based on responding to crises on different fronts, to a new and more positive phase, which should ultimately lead to the establishment of a new societal order.

discipline.<sup>274</sup> Long-termism in economic activity means that companies focus their economic activities not only on short-term gains, but also on longer-term viability and sustainability, usually expressed in ESG-terms. Just as stability, market integrity and consumer protection are tools to achieve a more efficient and fair economy in the service of economic growth, sustainable finance is not a goal in itself, but a tool in the service of a more sustainable economy.<sup>275</sup> Fostering long-termism in economic activity is, therefore, not a sub-objective of sustainable finance, but an expression of the constitutionally enshrined principle of sustainable development (see sub-section 3.1), which is the foundation and ultimate objective of sustainable finance. Fostering long-termism in financial activity, on the other hand, aims at stimulating long-term investments, informed by a long-term investment strategy.<sup>276</sup> An investor with a long-term investment strategy will typically pay more attention to ESG factors and risks than investors aiming at short-term profits.<sup>277</sup> This sub-objective is, therefore, a means to further the first sub-objective of sustainable finance, reorienting capital flows towards sustainable investments.

We conclude that of the three sub-objectives of sustainable finance analysed above, the first sub-objective, reorienting capital flows towards sustainable investments, seems to be the main objective of sustainable finance<sup>278</sup> and the only one that could potentially be considered an autonomous objective of financial regulation.

---

<sup>274</sup> Armour, J. et al. (2016), *Principles of Financial Regulation*, OUP, pp. 55-57, 66-67 and 102-10; de Haan, J. and others (2020), *Financial Markets and Institutions*, CUP, pp. 380-381; Moloney N. (2014), *EU Securities and Financial Markets Regulation*, OUP, p. 5.

<sup>275</sup> See COM(2021) 390 final, op. cit., p. 2.

<sup>276</sup> See, among others, Barton, D. and Wiseman, M. (2014), "Focusing capital on the long term", *Harvard Business Review*, No 44; Ambachtsheer, K. (2014), "The case for long-termism", *Rotman International Journal of Pension Management*, No 7, p. 6, <https://icpmnetwork.com/company/roster/companyRosterDetails.html?companyId=17766&companyRosterId=48>.

<sup>277</sup> Also in a sustainable economy it is, nevertheless, important to allow a flexible redirection of resources on short notice and to ensure an efficient price discovery process. Short-selling is, for instance, sometimes too easily branded as a non-sustainable, short-term investment strategy, even though it is an efficient means to swiftly bring about necessary price corrections in the market. Certain authors argue that the threat of short-selling actually urges companies to make long-term investments (Massa, M. and others (2015), "Saving long-term investment from short-termism: the surprising role of short selling" INSEAD Working Paper Series 2015/11/FIN <https://sites.insead.edu/facultyresearch/research/doc.cfm?did=55938>; Caby, J. (2020), "The Impact of Short Selling on Firms: An empirical literature review" *Journal of Business, Accounting and Finance Perspectives*, No. 2. For a nuanced view, also see ESMA (2019), "Report – Undue short-term pressure on corporations" (ESMA30-22-762), p. 99, para. 308.

<sup>278</sup> The European Commission confirmed this in its renewed sustainable finance strategy: "As the scale of investment required is well beyond the capacity of the public sector, the main objective of the sustainable finance framework is to channel private financial flows into relevant economic activities". European Commission (COM(2021) 390 final), op. cit., p. 2.

## 3 The incorporation of environmental considerations in the regulation and supervision of prudential risks

### 3.1 Overview

In this section, we analyse how the sustainable finance objective has been translated in the prudential framework for credit institutions in the EU.<sup>279</sup> We examine whether those measures indeed directly aim at reorienting capital flows towards sustainable investment, or can, in the end be considered as measures that first and foremost contribute to the stability, market integrity and/or consumer protection objective.

The integration of sustainable finance in the prudential framework for credit institutions has two important components. First, in its 2020 Guide on climate-related and environmental risks, the ECB has clearly formulated its supervisory expectations in regard of how banks should integrate climate-related and environmental risks into their business strategy, governance and risk management under the current regulatory framework.<sup>280</sup> In 2021, the ECB has mentioned as a supervisory priority for 2022-2024 ensuring that emerging risks are tackled, in view of (among other things) exposure to climate-related and environmental risks as a key vulnerability.<sup>281</sup> In its Single Supervisory Mechanism (SSM) supervisory priorities for 2023-2025, stepping up efforts to address climate change was again mentioned as priority.<sup>282</sup> Second, the EU legislator has also taken certain steps to step up the legal requirement in the Level 1 framework.

It is no wonder then that credit institutions have to take ESG considerations into account in each of the three pillars of prudential regulation: (i) minimum capital and liquidity requirements, (ii) the supervisory review and evaluation process (SREP) by the supervisor, and (iii) market discipline.

#### 3.1.1 First pillar

The 2020 ECB Guide on climate-related and environmental risks clarifies in respect of Pillar 1 capital requirements that banks have to take into account climate-related and environmental risks at all relevant stages of the credit-granting process and that they

---

<sup>279</sup> See also Elderson, F. (2023), "Climate-related and environmental risks – a vital part of the ECB's supervisory agenda to keep banks safe and sound", Speech, 23 June, <https://www.bankingsupervision.europa.eu/press/speeches/date/2023/html/ssm.sp230623-6731c533c7.en.html>.

<sup>280</sup> ECB (2020), "Guide on climate-related and environmental risks: Supervisory expectations relating to risk management and disclosure", November, <https://www.bankingsupervision.europa.eu/ecb/pub/pdf/ssm.202011finalguideonclimate-relatedandenvironmentalrisks-58213f6564.en.pdf>.

<sup>281</sup> ECB (2022), "Supervisory priorities for 2022-2024", [https://www.bankingsupervision.europa.eu/banking/priorities/html/ssm.supervisory\\_priorities2022-0f890c6b70.en.html#toc2](https://www.bankingsupervision.europa.eu/banking/priorities/html/ssm.supervisory_priorities2022-0f890c6b70.en.html#toc2).

<sup>282</sup> ECB (2023), "SSM Supervisory priorities for 2023-2025", 2.2.3. Priority 3, [https://www.bankingsupervision.europa.eu/banking/priorities/html/ssm.supervisory\\_priorities202212-3a1e609cf8.en.html](https://www.bankingsupervision.europa.eu/banking/priorities/html/ssm.supervisory_priorities202212-3a1e609cf8.en.html).



have to continuously monitor such risks in their portfolios.<sup>283</sup> They stress that these risks are not only important when assessing credit risk, but also when assessing operational risk, market risk and liquidity risk.<sup>284</sup>

Moreover, the amended Capital Requirements Regulation (EU) No 575/2013 has given a mandate to the European Banking Authority (EBA) to assess whether a specific prudential treatment of credit institutions' exposures to assets or activities which are mainly associated with environmental and/or social objectives would be justified.<sup>285</sup> EBA should, in particular, assess (i) methodologies for the assessment of the effective riskiness of exposures related to assets and activities associated substantially with environmental and/or social objectives compared to the riskiness of other exposures, (ii) the development of appropriate criteria for the assessment of physical risks and transition risks, including the risks related to the depreciation of assets due to regulatory changes, and (iii) the potential effects of a dedicated prudential treatment of exposures related to assets and activities which are associated substantially with environmental and/or social objectives on financial stability and bank lending in the EU.

Especially the third limb of the mandate has provoked some discussion that is particularly interesting for purposes of this paper. Some organisations have suggested that the reorientation of capital flows could be accelerated by rewarding credit institutions that finance sustainable projects, with more favourable capital requirements – a so-called 'green supporting factor' – or by punishing credit institutions that finance non-sustainable projects, with a 'brown penalty'.<sup>286</sup> EBA's report is due by 28 June 2025,<sup>287</sup> but the Authority already submitted a discussion paper on the role of environmental risks in the prudential framework on 2 May 2022.<sup>288</sup> In its report, EBA carefully weighs arguments for and against adjustment factors related to environmental risk drivers, making a distinction between a "prudential perspective" on the one hand, and a "public policy perspective" on the other hand. EBA clearly supports the prudential perspective, with important arguments against a dedicated prudential treatment of exposures related to environmental and/or social objectives.<sup>289</sup> Even though sustainable assets should in theory have a better risk profile in a transition to a more sustainable economy, this does not work if capital adjustment factors are not risk sensitive, which would possibly weaken risk sensitiveness of

---

<sup>283</sup> ECB, "Guide on climate-related and environmental risks", op. cit., p. 4, Supervisory Expectation 8.

<sup>284</sup> *ibid.*, pp. 4-5, Supervisory Expectations 9-12, and p. 11, see in particular also footnote 13.

<sup>285</sup> Article 501c Capital Requirements Regulation (Regulation (EU) No 575/2013 of the European Parliament and of the Council of 26 June 2013 on prudential requirements for credit institutions and investment firms and amending Regulation (EU) No 648/2012 (OJ L 176, 27.6.2013, p. 1) (Capital Requirements Regulation).

<sup>286</sup> European Banking Federation (2017), "Towards a Green Finance Framework", 28 September, pp. 33-34 and Annex I; Dombrovskis, V. (2017), "Greening finance for sustainable business", SPEECH/17/5235, 12 December, [https://ec.europa.eu/commission/presscorner/detail/en/SPEECH\\_17\\_5235](https://ec.europa.eu/commission/presscorner/detail/en/SPEECH_17_5235).

<sup>287</sup> Article 501quater Capital Requirements Regulation; Article 34 Investment Firms Regulation (Regulation (EU) 2019/2033 of the European Parliament and of the Council of 27 November 2019 on the prudential requirements of investment firms and amending Regulations (EU) No 1093/2010, (EU) No 575/2013, (EU) No 600/2014 and (EU) No 806/2014 (OJ L 314, 5.12.2019, p. 1) (Investment Firms Regulation). See for further details also Annex 4 of EBA's Discussion Paper EBA/DP/2022/02 (full reference in next footnote).

<sup>288</sup> EBA (2022), "The role of environmental risks in the prudential framework – Discussion Paper", (EBA/DP/2022/02, 2 May).

<sup>289</sup> *ibid.*, pp. 44-47, the rest of the paragraph is based on the table on p. 45.

institutions. Second, adjustment factors may bridge the gap between the shorter time horizon of capital requirements and the longer horizon for sustainability risks to materialise. However, since the Pillar 1 framework already recognises environmental risk drivers to a certain extent, adjustment factors would lead to double counting of environmental risk drivers. Third, increased capital requirements for exposures associated with higher environmental risks (a brown penalty), would strengthen the solvency of institutions, to account in the present for future risks. However, increased capital requirements could also lead to a shift in financing of currently less sustainable borrowers to non-bank financial intermediaries, some of which are outside the scope of prudential regulation. Fourth, while adjustment factors could correct potential over-reliance on historical data, they may misrepresent the dynamic development of environmental risks, whereas a more targeted adjustment of Pillar 1 instruments, using forward-looking ratings and models, would also recognise that the business model of corporates may be changing towards a more sustainable *modus operandi*. Fifth, adjustment factors in Pillar 1 would be homogeneous for all institutions in the EU, whereas Pillar 2 recommendations or guidance are more discretionary for supervisors.

EBA has in the past already advocated against other supporting factors (for infrastructure projects and for small and medium-sized enterprises), arguing that adjustments should be grounded on risk-based considerations. In view of this and the prudential arguments against such supporting factors or penalties, chances are small that EBA would support a dedicated prudential treatment of exposures related to E/S objectives in its final report.

### 3.1.2 Second pillar

In respect of the second Pillar of prudential regulation, EBA published a report in June 2021 on the management and supervision of ESG risks for credit institutions and investment firms.<sup>290</sup> The report discusses, among other things, the impact ESG factors can have on the counterparties of these financial institutions or on invested assets, and how these factors can influence financial risk. It also describes the available indicators, metrics and assessment methods that are necessary to integrate ESG factors and risks into the risk management and supervisory review process. On the basis of the outcome of this report EBA may, if appropriate, issue guidelines.<sup>291</sup> In

---

<sup>290</sup> See EBA's mandate in Article 98(8) Capital Requirements Directive (Directive 2013/36/EU of the European Parliament and of the Council of 26 June 2013 on access to the activity of credit institutions and the prudential supervision of credit institutions and investment firms, amending Directive 2002/87/EC and repealing Directives 2006/48/EC and 2006/49/EC (OJ L 176, 27.6.2013, p. 338) (Capital Requirements Directive) and Article 35 Investment Firms Regulation (EU) No 2019/2034; EBA (2021), "Report on management and supervision of ESG risks for credit institutions and investment firms", (EBA/REP/2021/18, June).

<sup>291</sup> Article 98(8) last paragraph Capital Requirements Regulation (EU) No 575/2013 and Article 35 last paragraph Investment Firms Regulation (EU) No 2019/2033. The ECB and the ESRB also cooperate to develop metrics and methodologies to assess the stability risks linked to climate change, as well as top down stress tests in this regard (ECB and ESRB (2020), "Positively green: Measuring climate change risks to financial stability", June, [https://www.esrb.europa.eu/pub/pdf/reports/esrb.report200608\\_on\\_Positively\\_green\\_-\\_Measuring\\_climate\\_change\\_risks\\_to\\_financial\\_stability-d903a83690.en.pdf](https://www.esrb.europa.eu/pub/pdf/reports/esrb.report200608_on_Positively_green_-_Measuring_climate_change_risks_to_financial_stability-d903a83690.en.pdf); ECB and ESRB (2021), "Climate-related risk and financial stability", July; ECB (2022), "Press Release – ECB Banking Supervision launches 2022 climate risk stress test", 27 January, <https://www.bankingsupervision.europa.eu/press/pr/date/2022/html/ssm.pr220127~bd20df4d3a.en.html>

2022, the ECB has performed a full supervisory assessment of climate-related and environmental risk practices. As a result, the ECB imposed binding qualitative requirements on more than 30 banks in its ongoing 2022 SREP, to address severe weaknesses. For a small number of banks, the outcome of the 2022 supervisory exercise on climate and environmental risks had an impact on their SREP scores, impacting their Pillar 2 capital requirements.<sup>292</sup>

### 3.1.3 Third pillar

Finally, sustainability has also been incorporated into the third Pillar of prudential regulation, market discipline. Since 26 December 2022, large credit institutions with securities admitted to trading on a regulated market have to disclose information on ESG risks, including physical risks and transition risks.<sup>293</sup> The EBA has been given a mandate to develop technical standards in this respect.<sup>294</sup>

The ECB has made three supervisory assessments of institutions' climate-related and environmental risk disclosures.<sup>295</sup> The latest assessment was finalised in November 2022 – before the entry into force of the new regulatory requirements. The various reports show a continuous improvement in compliance with the ECB expectations in this regard. The last report found that most banks have improved their public disclosures to address climate-related and environmental risks, having clearly built up their capabilities in 2022. Most banks disclose basic information on materiality assessments and governance, and more than half of the banks disclose basic information on business strategy, risk management, and metrics and targets. However, banks still need to close remaining gaps to disclose all relevant climate and environmental risk information: only 34 % of the banks disclose information on all categories. The ECB still concludes that, notwithstanding the better provision of information, the quality remains low and is unlikely to provide market participants with insights on which they can act. While not yet fully aligned with supervisory expectations, the disclosures of the largest European banks still outperform global peers across the board, when assessing those against the ECB standards.<sup>296</sup>

---

<sup>292</sup> ECB (2022), "Thematic Review on Climate and Environmental Risks. Final Results", 2 November, [https://www.bankingsupervision.europa.eu/ecb/pub/pdf/ssm.221102\\_presentation\\_slides-76d2334552\\_en.pdf](https://www.bankingsupervision.europa.eu/ecb/pub/pdf/ssm.221102_presentation_slides-76d2334552_en.pdf).

<sup>293</sup> Article 449bis and Article 434bis Capital Requirements Regulation (EU) No 575/2013.

<sup>294</sup> See EBA (2021), "Consultation Paper. Draft Implementing Standards on prudential disclosures on ESG risks in accordance with Article 449a CRR" (EBA/CP/2021/06, March). EBA consulted, among other things, on quantitative templates regarding a "green asset ratio" that shows which part of the institution's exposures contribute to environmental objectives and help to mitigate environmental risks (see pp. 11-12).

<sup>295</sup> ECB (2022), "ECB report on institutions' climate-related and environmental risk disclosures", November, [https://www.bankingsupervision.europa.eu/ecb/pub/pdf/ssm.ecbreportinstitutionsclimaterelatedenvironmentalriskdisclosures202011-e8e2ad20f6\\_en.pdf](https://www.bankingsupervision.europa.eu/ecb/pub/pdf/ssm.ecbreportinstitutionsclimaterelatedenvironmentalriskdisclosures202011-e8e2ad20f6_en.pdf); ECB (2022), "Supervisory assessment of institutions' climate-related and environmental risk disclosures", March, [https://www.bankingsupervision.europa.eu/ecb/pub/pdf/ssm.ECB\\_Report\\_on\\_climate\\_and\\_environmental\\_disclosures\\_202203-4ae33f2a70\\_en.pdf](https://www.bankingsupervision.europa.eu/ecb/pub/pdf/ssm.ECB_Report_on_climate_and_environmental_disclosures_202203-4ae33f2a70_en.pdf), and ECB (2023), "The importance of being transparent. A review of climate-related and environmental risks disclosures practices and trends", April, [https://www.bankingsupervision.europa.eu/ecb/pub/pdf/ssm.theimportanceofbeingtransparent042023-1f0f816b85\\_en.pdf](https://www.bankingsupervision.europa.eu/ecb/pub/pdf/ssm.theimportanceofbeingtransparent042023-1f0f816b85_en.pdf).

<sup>296</sup> *Ibid.*, 3-4.

## 3.2 Evaluation

### 3.2.1 Changes to prudential regulation so far

The above overview shows that existing prudential regulation is being amended or interpreted to ensure that credit institutions take ESG risks into account in their risk assessment practices. This will no doubt lead to a more accurate assessment of risks, so that the capital requirements of these financial institutions will be better aligned with their risk profile. The amendments therefore first and foremost result in a more sophisticated concretisation of the stability objective, in keeping with the second sub-objective of the Action Plan: managing financial risks stemming from climate change, resource depletion, environmental degradation and social issues.

Indirectly this more sophisticated risk assessment will undoubtedly also have an impact on the first sub-objective, the reorientation of capital flows towards sustainable projects and activities. When financial institutions take ESG risks into account in their credit-granting and investment-decision processes, this will inevitably be reflected in a higher financing cost for those counterparties, projects and products representing with a higher ESG-risk. This can, in turn, be a powerful incentive for these companies to improve their ESG risk profile and thus lower their cost of financing.<sup>297</sup>

In addition, a number of amendments should increase transparency on the sustainability risks financial institutions assume (Pillar 3). These transparency measures aim to promote market discipline, so that market participants can better assess the risk profile of financial institutions, also in regard of the integration of ESG factors into their risk management policy. These transparency requirements and resulting reduction of information asymmetry should in principle lead to a more efficiently functioning market, more market integrity and investor protection. Indirectly these transparency requirements may also advance the sustainable finance objective. They may incentivise credit institutions to develop more sustainable business and risk strategies, especially if they feel they could then benefit from a market sentiment favouring sustainability. Those indirect sustainable finance effects, however, depend on ample prevalence of sustainability preferences among market participants and on effective measures to prevent greenwashing.<sup>298</sup>

### 3.3 Green supporting factor / brown penalty

More far-reaching measures, directly impacting the sustainable finance agenda, such as a 'green supporting factor' or a 'brown penalty', are being considered. Such measures could not be explained on the basis of bank stability, market integrity or consumer protection and would therefore make sustainable finance an autonomous

---

<sup>297</sup> See in this sense: Masters, B. (2021), "How to handle the ESG laggards", Financial Times - FTfm Responsible Investing, 18 October, p. 11, last paragraph: "... banking regulators are starting to include climate impacts in their stress tests. If that prompts the financial services industry to shy away from bankrolling "brown" companies and those that ignore social and governance expectations, the pressure will be much more intense".

<sup>298</sup> Colaert, V., op cit., pp. 1687-1688 and 1697-1698.

objective of financial regulation, when introduced. In general, however, commentators reject such measures, because they would promote sustainability at the expense of stability. They stress that the main goal of capital requirements for banks, investment firms and insurance companies is to ensure financial stability. A sustainable investment approach should, in their view, only lead to lower capital requirements if the sustainability of those projects is reflected in a lower (ESG-) risk profile.<sup>299</sup>

However, only a 'green supporting factor' would promote sustainable finance at the expense of financial stability. A 'brown penalty', by contrast, which would oblige financial institutions to meet higher capital requirements if investing in 'brown' activities or projects, would not impair financial stability. But also imposing a brown penalty may have a number of unintended and undesired effects. Both types of 'dedicated prudential treatment' could lead to so-called 'stranded assets' which are no longer financed, but for which no alternative exists yet. Moreover, they could lead to a rush on 'green assets', which may result in an unhealthy asset bubble (and resulting stability risks) if offer is smaller than demand for such products.<sup>300</sup> Policymakers should very carefully assess those potential effects before introducing far-reaching sustainable finance measures that have the potential of undermining traditional objectives of financial regulation.

## 4 Relationship between sustainable finance and traditional policy objectives

This brings us to the second question, i.e. how regulators should prioritise the objectives of financial regulation in case they conflict. Even though each situation needs to be assessed in the light of the concrete circumstances, we put forward a number of guiding principles. The first two serve as general principles in case of conflicting policy objectives of financial regulation, while the third one is specific to the sustainable finance objective.

First, in case of a possible conflict between objectives, a hard choice is often not required. A cost-benefit analysis may help in designing balanced measures. A green supporting factor, for instance, is unlikely to be implemented, since there are other measures, that may advance the sustainable finance objective just as much, without undermining the stability objective. A brown penalty, for instance, would reach the

---

<sup>299</sup> Matikainen, S. (2017), "Green doesn't mean risk-free: why we should be cautious about a green supporting factor in the EU", 18 December, LSE Commentary <https://www.lse.ac.uk/granthaminstitute/news/eu-green-supporting-factor-bank-risk/>; Boot, A. and Schoenmaker, D. (2018) "Climate change adds to risk for banks, but EU lending proposals will do more harm than good", 17 January, Bruegel ThinkTank Blogpost <https://www.bruegel.org/2018/01/climate-change-adds-to-risk-for-banks-but-eu-lending-proposals-will-do-more-harm-than-good/>; Ford, G. (2018) "A green supporting factor would weaken banks and do little for the environment", 2 February, <https://www.finance-watch.org/a-green-supporting-factor-would-weaken-banks-and-do-little-for-the-environment/>; Dankert, J. et al. (2018), "Green Supporting Factor — The Right Policy?", October, SUERF Policy Note, Issue No 43 <https://www.suerf.org/policynotes/3473/a-green-supporting-factor-the-right-policy>. Also see Sustainable Finance Action Plan, op. cit., p. 9.

<sup>300</sup> Similarly: De Arriba-Sellier, N. (2021), "Turning gold into green: green Finance in the mandate of European financial supervision", *CMLRev*, No 58, p. 1129.

same goals, without undermining stability (even if it may have other drawbacks, as discussed above).

Second, in case of a conflict between the traditional objectives of financial regulation, the stability of the financial system should prevail. Economically, the amounts at stake in regard of macro-stability significantly outweigh potential liabilities in regard of the other traditional policy objectives.<sup>301</sup> Legally, macro-stability is the ultimate public interest objective.

Third, the sustainable finance objective should give way to the traditional objectives of financial regulation in case of a conflict. This may seem counter-intuitive, since sustainable finance is a tool in the service of a sustainable economy and a sustainable future for our planet, which should arguably be given the highest priority. However, sustainable finance measures are just one tool in the legislator's toolbox to achieve this ultimate goal. Measures in other policy domains, such as tax law, environmental law, product regulation, and labour law, may have an equal or even higher impact in this respect. The same is not true for the traditional objectives of financial regulation. Stability, market integrity and consumer protection are to be fostered first and foremost with financial regulation. Stability, market integrity and a high level of consumer protection are in themselves, moreover, also fundamental preconditions for attaining a sustainable economy in the longer term. Therefore, sustainable finance measures that would undermine stability, market integrity or consumer protection, should be discarded and replaced with alternative tools to further a sustainable economy, such as tax incentives, or direct environmental law or labour law.

Sustainable finance regulation should therefore be considered as an important intermediate tool to nudge companies to apply higher ESG standards than legally required, pending stricter direct environmental, social and governance regulation. It is a potentially strong tool, since companies have an incentive to live up to such higher standards, in order to more readily secure funding.

## 5 Conclusion

In view of the growing importance of sustainable finance as a policy objective of the EU, in this contribution we have examined (i) whether sustainable finance should be considered as a new autonomous objective of prudential regulation, and (ii) how this objective should stand in relation to the traditional objectives of financial regulation, namely stability, market integrity and consumer protection.

In respect of the first question, we conclude that sustainable finance is not an autonomous objective of prudential regulation yet, as all sustainable finance amendments to prudential regulation can, so far, be fully explained on the basis of the traditional objectives. However, if a green supporting factor or a brown penalty would be introduced, such measures could not be explained on the basis of stability, market

---

<sup>301</sup> For instance, Wymeersch, E. (2007), "The Structure of Financial Supervision in Europe: About Single Financial Supervisors, Twin Peaks and Multiple Financial Supervisors", *European Business Organization Law Review*, No 8, p. 245; Armour and others, op. cit., p. 70.

integrity or consumer protection objectives. They would serve no other objective than reorienting capital flows to sustainable investments, while being neutral or even detrimental to the traditional policy objectives. Sustainable finance would then become an autonomous objective of prudential regulation. This would, however, not necessarily be a good thing.

It brings us to the second question addressed in this contribution, namely how regulators should prioritise the objectives of financial regulation if furthering one objective would undermine another. We conclude that the sustainable finance objective should give way to the traditional objectives of financial regulation in case of a conflict, because (i) sustainable finance is just one tool in the toolbox to achieve a more sustainable economy, whereas the other objectives of financial regulation can only be attained via financial regulation, and (ii) stability, market integrity and consumer protection are in themselves key conditions for a long-term sustainable economy.

This means that a green supporting factor, which would conflict with the stability objective, should be avoided. A brown penalty has more potential from this perspective, since it would not directly conflict with the stability objective. However, it may have some unintended perverse effects (such as a green asset bubble, stranded assets or greenwashing), which regulators should carefully assess when deciding whether or not to introduce such a measure.







## Part IV

# Central bank immunities and international sanctions

# Central bank immunities and international sanctions: an introduction

Chiara Zilioli\*

## 1 Introduction

The law of immunities has been a highly debated topic among international lawyers for many years. A notable example of this controversy is the lengthy debate between Italy and Germany regarding whether immunities can be invoked as a defence in cases where this would prevent victims from obtaining justice for atrocities committed during armed hostilities. This dispute has even led to a case before the International Court of Justice (ICJ), which seems to have been settled only this summer.<sup>302</sup>

The principle of State immunity has developed as a principle of customary international law. It is founded on the principle *par in parem non habet imperium*, by virtue of which one State is not subject to the jurisdiction of another State. It thus reflects the fundamental principle of sovereign equality of States.

As a principle of customary international law, the scope of application of State immunity is determined by State practice combined with *opinio iuris*.<sup>303</sup> Evidence of such practice may be found in treaties, decisions of national and international courts, national legislation, opinions of national legal advisors, diplomatic correspondence and actions of international organisations.

While the United Nations Convention on the Jurisdictional Immunities of States and Their Property (UNCSI)<sup>304</sup> has not entered into force and has only been ratified by 22 States, it is considered as an authoritative expression of customary international law.

State immunity encompasses immunity from adjudication (a procedural rule preventing a foreign State from participating in judicial proceedings before the courts of another state) and immunity from execution, according to which State assets cannot be subject to measures of enforcement.

---

\* Director General Legal Services, European Central Bank (ECB), Professor at the Law Faculty of the Goethe University in Frankfurt am Main.

<sup>302</sup> See Pelliconi, A.M. (2023), "The Italian Constitutional Court's new decision on state immunity and the ICJ Germany vs Italy No. 2", *EJIL:Talk!*, 28 July, available at <https://www.ejiltalk.org/the-italian-constitutional-courts-new-decision-on-state-immunity-and-the-icj-germany-vs-italy-no-2/>. On the judgment delivered by the International Court of Justice, see Milanovic, M. (2012), "Germany v. Italy: Germany Wins", *EJIL:Talk!*, 3 February, available at <https://www.ejiltalk.org/germany-v-italy-germany-wins/>.

<sup>303</sup> See Article 38(1)(b) of the Statute of the International Court of Justice as well as the UN Resolution on the identification of customary international law (11.01.2019, A/RES/73/203).

<sup>304</sup> UN Convention on the Jurisdictional Immunities of States and Their Property (2.12.2004, UN Doc. A/59/508).

Immunity from adjudication is not absolute. It is generally recognised that the State enjoys immunity for acts *iure imperii*, but not for acts *iure gestionis*, which are comparable to acts performed by private persons in relations governed by private law. As regards immunity from execution, a similar move towards a limitation to property held *iure imperii* has been observed in State practice.

The relevance of immunities concerning sanctions imposed on central banks has come to the fore as part of a broader trend of increased interference with central bank assets located abroad.

Such interference has increased both in scale and scope, ranging from temporary restrictions to permanent expropriation. In particular on 28 February 2022, four days after Russian forces invaded Ukraine, Western States holding assets of the Russian Central Bank took coordinated action to ban all transactions with the Russian Central Bank by their citizens and within their territory.

This development opened a new chapter in the debate on sanctions against central banks for three reasons.

First, the amount of central bank reserve assets affected is significant, especially when compared to the assets of listed private individuals and entities.

Second, until now, sanctions have applied to smaller central banks with a relatively minor role in the international monetary system. This time is different. The freezing of Russian central bank reserves has been described as a crossing of a political and economic Rubicon. As noted by Adam Tooze,<sup>305</sup> if central bank reserves of one G20 member that are entrusted to the accounts of another G20 central bank are not sacrosanct, then nothing in the financial world is. This is a qualitative change.

Third, new proposals have been made to use central bank reserve assets to pay reparations to Ukraine. These proposals range from outright confiscation to using the proceeds from these assets. The key distinction lies in the fact that, unlike sanctions, which are temporary measures designed to persuade a State to change its international policies, these proposals are aimed at reparations.

## 2 The broader legal and political context

Dealing with interference in central bank assets raises a broader question about how we, as the international community – or perhaps more precisely the West – can effectively address threats to global peace and security while:

1. maintaining respect for the (international) rule of law – “don't become the monster you are fighting”; and
2. avoiding further geopolitical fragmentation of the world economy, as this could not only reverse the economic benefits of globalisation but also, and more

---

<sup>305</sup> Tooze, A. (2022), “The world is at financial war”, *The New Statesman*, 2 March, available at <https://www.newstatesman.com/ideas/2022/03/ukraine-the-world-is-at-financial-war>.

importantly, trigger wider confrontation. It is essential to demonstrate that we have learned from the past and to recognise the dangers of economic entrenchment and confrontation.

These issues are complex as they involve multiple legal, political and economic dimensions. As lawyers, we face a particular challenge. Interpretations often contradict each other, judicial pronouncements are scarce, and States often argue on the basis of political expediency rather than the law.

There is little explicit jurisprudence and doctrine on sanctions and, in particular, immunity rules, and some authors refer to this gap as a "blind spot" ("un angle mort") in international law.

Let me indicate three open questions that are particularly relevant from the perspective of international law in this respect.

## 2.1 Scope of immunity: are central banks' assets protected by State immunity?

As noted, the UNCSI, which is not in force but largely reflects customary international law, suggests a broad understanding.

With respect to central bank property, Article 21(1)(c) of the UNCSI protects "property of the central bank or other monetary authority of the State". This can be read as an irrefutable presumption that any central bank assets are property *iure imperii*. The absolute protection of central bank assets was controversial among States both in the International Law Commission's preparatory works on the UNCSI and in the United Nations. Therefore, it cannot be certain whether Article 21(1)(c) of the UNCSI reflects customary international law. National practice differs on this point.

State practice varies. One perspective taken by courts in England and Wales<sup>306</sup> as well as the Netherlands<sup>307</sup> and based on the UNCSI posits that the immunity of central bank property under Article 21(1)(c) applies to all assets handled by a central bank and is "categorical" in nature, meaning that the immunity does not depend on the use of the assets in question. An alternative viewpoint represented by a relatively recent Swedish precedent<sup>308</sup> leans towards a functional approach, in line with the practice of countries such as Germany<sup>309</sup> and the United States (US).<sup>310</sup> These courts recognise a separate, enhanced immunity for central bank property, but require that the central bank holds such funds for "sovereign purposes" or "on its own account". In practice, this limits central bank immunity to funds used for typical or paradigmatic central bank activities and functions.

---

<sup>306</sup> England High Court Queen's Bench Division, *A/C Ltd. v Federal Government of Nigeria*, Case No EWHC 1357 [2003].

<sup>307</sup> Supreme Court of the Netherlands, Cases 19/03142 *Republic Kazakhstan v Stati and Others* and 19/03144 *Samruk-Kazyna JSC v Stati and Others* [2020].

<sup>308</sup> Case No Ö 3828-20, *Ascom* NJA 2021.

<sup>309</sup> Federal Court of Germany, Decision of 4 July 2013, VII ZB 63/12.

<sup>310</sup> US Court of Appeals Second Circuit, *NML CAPITAL, LTD v BCRA*, 652 F.3d 172 (2d Cir. 2011).

## 2.2 Does immunity only apply to court procedures or also to acts of the executive?

Immunity rules clearly apply to interference with judicial proceedings, in that courts are not allowed to interfere with public property abroad. However, what about actions taken by political branches, such as the executive or the legislature? Most sanctions are not related to judicial proceedings.

The freezing of the assets of the Central Bank of Russia was carried out by direct executive action, not by “coercive measures in connection with proceedings before a court”. In this case, the freezing is based on a Council decision, not a court ruling.

Scholarly opinion is divided as to whether immunity from execution applies to situations beyond the enforcement of court judgments. One view is that both immunity from execution and jurisdictional immunity must be linked to some judicial process, and are therefore not relevant to most sanctions against central banks. The idea that State immunity rules are triggered only when there is a “proceeding” before a “court” was vigorously defended by Australia in its (now terminated) case with Timor-Leste before the ICJ.<sup>311</sup>

According to another view, immunities are relevant also with regard to measures adopted by the executive. This stems from the belief that (i) it would be rather incongruous if central bank immunity could be invoked against judicial intervention but not against executive intervention, and (ii) establishing a sharp distinction between judicial and executive action may be difficult to apply in practice, for example when an executive order to seize foreign State property must first be approved by a judge before it can take effect or when the executive order is challenged in court. The customary rule of State immunity from execution protects State property against all State acts, not only (extensions of) judicial acts of a State. This view is supported by the general aim of the principle, which is to limit the power of one State over another. As Timor-Leste has argued before the ICJ against Australia, State property would be “in the absurdly paradoxical position of being inviolable and immune from judicial action, but at the mercy of administrative or executive action”.

## 2.3 Can sanctions be justified as countermeasures?

If State immunity is deemed to apply to sanctions or expropriation of central banks' assets, consideration may need to be given to justifying them as countermeasures under international law. The question that arises is whether such measures could be taken on behalf of a third party or on behalf of collective interests such as international peace and security.

A countermeasure is an act of a State against another State that would otherwise be wrongful, but it is not considered wrongful where and to the extent that it is taken to induce the other State to comply with its own obligations and is also consistent with

---

<sup>311</sup> See Counter-Memorial of Australia, *Questions relating to the seizure and detention of certain documents and data (Timor-Leste v Australia)*, para. 5.104.

the limits and conditions on countermeasures set out in the Chapter of the International Law Commission (ILC) Articles on the Responsibility of States for Internationally Wrongful Acts (ARSIWA).

These Articles expressed the idea of reversibility of countermeasures in Article 49 of the ARSIWA. The key concepts of this provision are threefold.

First, countermeasures are meant "to induce" an offending State to comply with its obligations, rather than to punish it (or to coerce it beyond the objective of inducing compliance).

Second, these measures are temporary as they are "limited to the provisional non-performance" of the obligations of the State taking countermeasures.

Third, these measures are reversible as they are taken "as far as possible in such a way as to permit resumption of the performance of the obligations in question". This, however, is a relative rather than an absolute condition.

Applied to the present situation, the question is whether the sanctions against Russia can be qualified as countermeasures. According to one view, the ban on transactions with the assets of the Central Bank of Russia has the characteristics of a countermeasure. The frozen assets remain untouched and control over them can be returned to Russia after it has ended its aggression. The asset freeze could, therefore, be seen as a permissible third-party countermeasure to induce Russia to stop its aggression against Ukraine (although the G7 did not phrase their measure in these terms). On the other hand,, where measures such as asset confiscation are concerned, it would be more difficult to argue that these are permissible third-party countermeasure. Confiscation would lack the essential characteristics of a countermeasure, and could not be qualified as such.

Finally, there is the question of whether immunities could be lifted in some very serious situations. Famously, in the case of *Germany v Italy* (jurisdictional immunities of the State), the ICJ ruled that it was not possible to derogate from State immunity in order to promote compliance with peremptory norms of international law, in this case fundamental rights.<sup>312</sup>

### 3 Conclusion

How we deal with these issues is crucial for determining our responses to violations of international law and for shaping, through State practice, the international order we wish to promote. This is not solely a concern for the Western nations but an affair that pertains to the entire world.

Again, we need to preserve the international order as a rule-based system rather than an anarchic environment where anything goes. Additionally, we need to avoid a retreat

---

<sup>312</sup> Case of the International Court of Justice No 2012/2, *Germany v Italy*, paras. 92-97.

into economic parochialism, or what the International Monetary Fund has aptly called geo-economic fragmentation.

The following experts address in their contributions to the book these complicated issues.

**Professor Ingrid Brunk** delves into the growing impact and scale of sanctions imposed on central banks, pointing out specific cases such as Afghanistan, Venezuela, Iran, and Russia. She discusses the contentious nature of economic sanctions, especially when extended to foreign States and State institutions rather than individuals. Professor Brunk also devotes particular attention to sanctions specifically directed at central banks and highlights the intersection of domestic and international law regarding foreign sovereign immunity.

In his contribution, **Mr. Rick Ostrander** provides an intriguing perspective on the matter, focusing on the US legal framework. He examines the US Foreign Sovereign Immunities Act of 1976, and in particular the heightened immunity from attachment and execution granted to foreign central bank property located in the US, and delineates the pivotal role played by the Federal Reserve Bank of New York by holding accounts for foreign central banks and monetary authorities. Lastly, he discusses interrelated immunity issues arising from recent events in Afghanistan, including provisions of the Terrorism Risk Insurance Act of 2002 and the Justice Against Sponsors of Terrorism Act.

Finally, **Dr. Iryna Bogdanova** outlines the diverse economic measures against Russia. First, she explains how – since the invasion of Ukraine – the economic sanctions imposed on Russia have been significantly upscaled, ranging from measures against Russian sovereign debt and freezing of the Russian Central Bank's assets to technological and transportation sanctions. Secondly, she summarises the legal and policy discussions that are currently taking place regarding the possibility of using frozen Russian assets belonging to the Central Bank and private individuals and legal entities to fund Ukraine's reconstruction.



# Sanctions, Asset Freezes, Confiscations and Immunity: an Overview

Ingrid (Wuerth) Brunk\*

## 1 Introduction

Sanctions imposed on central banks are not new, but they are growing in scale and significance. Sanctions currently imposed on Afghan, Venezuelan, Iranian, and Russian central banks, for example, involve an unprecedented amount of money and have generated heated legal and policy debates around the world. In addition to providing an overview of sanctions (section 2), this contribution addresses the following topics: asset freezes (section 3), confiscations (section 4), and immunity (section 5), before drawing some conclusions (section 6).

## 2 Sanctions

Economic sanctions are controversial as a whole. Governments use them against a wide range of foreign actors, including private individuals and corporations, state officials, state-owned enterprises, and states themselves. Sanctions are especially controversial when imposed on foreign states and state institutions, rather than on individuals, and when they are 'unilateral', meaning that they operate outside of a decision by the United Nations (UN) Security Council.<sup>313</sup> Detractors – including many countries in the global south – argue that sanctions on states harm vulnerable populations, serve as tools of coercion wielded by powerful Western nations, and are ineffective at producing the desired changes in behavior.<sup>314</sup> Proponents maintain that sanctions are a helpful way to curtail negative conduct by foreign states such as terrorism, espionage, human rights violations, unlawful weapons programs, and aggression. The United States (US) has been a global leader in imposing sanctions, but it is far from alone in using this form of economic pressure. China has recently acted to impose sanctions on the US.<sup>315</sup>

Sanctions imposed specifically on central banks are part of this broader debate. But they also raise distinct issues, especially when it comes to domestic and international law governing foreign sovereign immunity.

---

\* Professor and expert on public international law, transnational litigation, and foreign relations law.

<sup>313</sup> Hovell, Devika (2019), 'Unfinished Business of International Law: The Questionable Legality of Autonomous Sanctions,' Vol. 113 *AJIL* Unbound, pp. 140–145.

<sup>314</sup> Mulder, Nicholas (30 January 2022), 'How America Learned to Love (Ineffective) Sanctions,' *Foreign Policy*.

<sup>315</sup> Malkawi, Bashar (21 July 2023), 'Here's how China is responding to US sanctions – with blocking laws and other countermeasures,' *The Conversation*.

### 3 Asset Freezes

Speaking in broad terms, central bank sanctions take two forms. Most sanctions ‘freeze’ or immobilize assets in one way or another, but do not transfer ownership.

For example, the US sanctioned Banco Central de Venezuela in 2019 to prevent it “from being used as a tool of the illegitimate Maduro regime, which continues to plunder Venezuelan assets and exploit government institutions to enrich corrupt insiders.”<sup>316</sup> A designation works by prohibiting people and entities from transacting with the sanctioned entity. More specifically, the order concerning the Venezuelan central bank prohibited “all dealings by US persons or within (or transiting) the United States that involve any property or interests in property of blocked or designated persons.” Some licenses are issued to permit certain exceptions.<sup>317</sup> Sanctions of this kind can last for decades or more, they can serve as leverage in ongoing disputes, and they can have a profound effect on the populations of the sanctioned country, but they do not involve a formal change of ownership. In other words, they freeze, but they do not ‘confiscate’. They also eschew any direct legal control over the frozen asset itself – the order prevents other people or corporations from engaging in transactions with the sanctioned entity.

Some sanctions regimes appear to effect a change in ownership through a designation about who represents a foreign state. For example, the US and the United Kingdom (UK) designated Juan Guaido as the representative of the Venezuelan government for the purpose of access to and control over Venezuelan central bank assets. Formally, however, Venezuela remained the ‘owner’ of those assets. Similarly, in an effort to ensure that the Taliban did not have access to Afghan Central Bank assets located in the US, the United States named the ‘Afghan Fund’ in Switzerland to control the disposition of USD 3.5 billion of Afghanistan’s Central Bank assets that were located in the US.<sup>318</sup> Decisions about the money will be made by two Afghan economists and a representative each from the US and Swiss governments. Disbursements of central bank money are supposed to be made “for the benefit of the Afghan people” – meaning macroeconomic policy; however, so far no expenditures have been authorized.<sup>319</sup> These controversial ‘recognitions’ of specific government representatives for the sole purpose of controlling central bank assets are not formal confiscations, even if they may violate duties owed the state itself or to the government actually in control of the state.<sup>320</sup>

---

<sup>316</sup> See Press Release, United States Department of Treasury, Treasury Sanctions Central Bank of Venezuela and Director of the Central Bank of Venezuela (17 April 2019), <https://home.treasury.gov/news/press-releases/sm66>.

<sup>317</sup> *ibid.*

<sup>318</sup> Brunk, Ingrid (22 December 2022), ‘The Fate of the Afghan Central Bank Assets – State of Play,’ *Transnational Litigation Blog*.

<sup>319</sup> Cartier, Catherine (21 October 2023), ‘A Year on, Billions in Afghan Assets Linger in Switzerland,’ *The Diplomat*.

<sup>320</sup> Brunk, Ingrid (2023), ‘Central Bank Immunity, Sanctions, and Sovereign Wealth Funds,’ *Geo. Wash. L. Rev.*

## 4 Confiscations

Some sanctions do confiscate. Such measures take foreign central bank assets located in or under the control of the host country and permanently turn them over to new owners – usually new owners who were harmed by the country that is being sanctioned. These kinds of sanctions are far less common than asset freezes.

In domestic law, many sanctions regimes do not involve the power to confiscate, so confiscation may require specific legislation for that purpose. The US, for example, has enacted legislation that allowed central bank assets of Iran to be used to compensate people who had won court judgments against Iran in terrorism-related cases.<sup>321</sup> The US is also considering legislation that would confiscate Russian Central Bank assets.<sup>322</sup> The draft legislation provides that “[t]he President may confiscate any Russian sovereign assets subject to the jurisdiction of the United States.” The president does not enjoy any comparable peacetime authority under any other US statute.<sup>323</sup>

Confiscations may also raise distinct constitutional issues because they involve permanent deprivations of property, which may require different procedural safeguards than those in place for asset freezes. Such deprivations may, for example, require judicial review or involvement.<sup>324</sup> The legislation proposed in the US would give the president acting alone the power to confiscate Russian Central Bank assets without a judicial hearing or any process by an administrative agency. Such measures arguably violate US constitutional law.<sup>325</sup> And as a matter of international law, confiscations may violate bilateral investment treaties and customary international law on expropriations.

## 5 Immunity

Immunity (conferred both by domestic and by international law) is one of the most important limitations on the power of sanctioning countries over foreign central banks and their assets.

In general, immunity limits domestic judicial power over foreign states and their assets.<sup>326</sup> Immunity has two parts, (i) immunity from lawsuits themselves, and (ii) immunity from measures of execution or constraint. So, for example, Russia is presumptively immune from domestic lawsuits in Japanese courts, and Japanese

<sup>321</sup> See Iran Threat Reduction and Syria Human Rights Act of 2012, 22 US Code section 8772 and Terrorism Risk Insurance Act of 2002 (TRIA).

<sup>322</sup> See Rebuilding Economic Prosperity and Opportunity (REPO) for Ukrainians Act, H.R. 4175 (introduced 15 June 2023).

<sup>323</sup> For a discussion of the President’s war time power to confiscate alien enemy property, see Bishop, Joseph W. (1942), ‘Judicial Construction of the Trading with the Enemy Act,’ *Harvard L. Rev.* Vol. 721; Moiseienko, Anton (2022) ‘Trading with a Friend’s Enemy,’ *American J. of Int’l Law*.

<sup>324</sup> Chachko, Elena (2019), ‘Due Process Is in the Details: US Targeted Economic Sanctions and International Human Rights Law,’ Vol. 113 *AJIL Unbound*.

<sup>325</sup> On whether Russia (and other foreign states) have due process rights under the US Constitution, see Brunk (Wuerth), Ingrid (2019) ‘The Due Process and Other Constitutional Rights of Foreign States,’ *Fordham L. Rev.*

<sup>326</sup> Brunk, Ingrid (7 March 2022), ‘Does Foreign Sovereign Immunity Apply to Sanctions on Central Banks?,’ *Lawfare*.

courts cannot constrain Russian state property located in Japan. Both kinds of immunity protect foreign states as a whole, including but not limited to central banks. There are important exceptions to both forms of immunity, especially for commercial activity and commercial conduct by foreign states.

Central bank assets are also entitled to special, heightened immunity from measures of execution or constraint imposed by domestic courts. In other words, exceptions that may apply to other state-owned assets do not apply when it comes to the property of foreign central banks located in the forum state.<sup>327</sup> The goal of this very high level of immunity is to preserve financial stability, especially for foreign currency reserves.

Sanctions on foreign central banks that confiscate assets usually involve an exercise of judicial power. If so, they may violate the robust protection provided by the customary international law governing immunities. In the US, for example, there is ongoing litigation to turn Afghan Central Bank assets over to creditors who hold terrorism-related judgments against the Taliban.<sup>328</sup> If successful, such efforts are likely to violate customary international law on immunity. Sanctions that involve the judicially-mandated turnover or confiscation of central bank assets have led to diplomatic protests and to litigation before the International Court of Justice brought by Iran against the US and, separately, Canada.<sup>329</sup> In general, violations of immunity law may potentially be excused under the doctrine of countermeasures. However, the principle that underlies countermeasures is inducement, a rationale that does not easily justify the permanent confiscation of assets to pay damages to an injured party.<sup>330</sup>

Note, however, that most central bank's sanctions involve asset freezes. Those freezes are conducted through executive – not judicial – power and under current state practice, freezes imposed through executive measures do not implicate immunity at all. This point is supported by virtually all state practice, including state practice involving Russian Central Bank assets. Countries around the world used executive branch measures to freeze Russian central bank assets following the full-scale invasion of Ukraine, with no concern expressed about immunities. On the other hand, states wanted to confiscate Russian Central Bank assets, generally through measures that would involve judicial action. However, states did not do so, largely out of concerns about foreign sovereign immunity. This pattern of state practice is consistent with practice in other situations as well: judicial measures implicate immunity, executive measures do not.<sup>331</sup>

---

<sup>327</sup> Brunk (Wuerth), Ingrid (2018), 'Immunity of Central Bank Assets from Measures of Execution,' in Ruys, Tom, Angelet, Nicolas and Ferro, Luca (eds.), *Cambridge Handbook of Immunities and International Law*, Cambridge University Press.

<sup>328</sup> *In re Terrorist Attacks on 11 September 2001*, see the Memorandum Decision and Order (S.D.N.Y. 21 February 2023) (denying efforts by terrorism judgment creditors to force turnover of Afghan central bank assets).

<sup>329</sup> See Jamshidi, Maryam (24 July 2023), 'Iran's ICJ Case against Canada Tests the Terrorism Exception to Sovereign Immunity,' *Just Security and Dodge*, Bill (25 October 2023) 'Further Thoughts about Terrorism Exceptions and State Immunity,' *Transnational Litigation Blog*.

<sup>330</sup> Brunk, Ingrid (3 May 2023) 'Countermeasures and the Confiscation of Russian Central Bank Assets,' *Lawfare*.

<sup>331</sup> Thouvenin, Jean-Marc & Grandaubert, Victor (2019), 'Material Scope of State Immunity from Execution' in *Cambridge Handbook of Immunities and International Law*, <sup>supra</sup> note 15 (acknowledging the state practice supports immunity as a limitation on judicial but not executive power).

The distinction between judicial and executive branch measures for the purposes of immunity is contested by some scholars, however, for several reasons. First, the general opposition to unilateral sanctions leads to efforts to characterize all such sanctions as violations of international law – and immunities are often cited (with little support) as the norm that all sanctions violate. Second, sanctions are often characterized as examples of ‘countermeasures’, but that characterization means that sanctions must otherwise be unlawful, or else they would constitute ‘retorsions’. Here, too, immunity is cited as the norm that is generally violated by all sanctions, so that all sanctions can be characterized as state practice of countermeasures – even though states themselves do not designate sanctions as countermeasures.<sup>332</sup> More sophisticated arguments correctly note that the line between ‘judicial’ and ‘executive’ measures is a blurry one, and there may be little principled reason to condemn judicially-imposed confiscations as unlawful while concluding that executive-imposed confiscations pose no immunity problems. Actions by administrative agencies that confiscate property with limited possibility for judicial review may, for example, be difficult to characterize as either judicial or executive in nature.

Nonetheless, immunity is a limitation on judicial power – a limitation on personal or property-based jurisdiction of the courts or other judicial actors. Historically, foreign state immunity was largely about claims against or involving ships because ships traveled to other countries and in doing so potentially became subjected to foreign judicial process.<sup>333</sup> Immunity is and was a limitation on judicial power, not a doctrine that covers all bad things that states do to property owned by governments, including the bad things that they might do to foreign central bank assets through executive action. Conduct by the executive might be limited by protections afforded to alien property, by the principle of non-intervention, by domestic constitutional protections, or other legal frameworks, but not by immunity.

## 6 Conclusions

At the international level, central bank immunity is governed largely by customary international law rather than through treaties. The scope of the international legal obligations to confer immunity has waxed and waned over time. Foreign sovereign immunities in general have become less extensive as customary international law developed exceptions, including for commercial activities. But central bank immunity (at least as applied to traditional central banking functions) remains nearly absolute and domestic practice over the last few decades has moved in the other direction, generally increasing the level of protections afforded to foreign central bank assets.<sup>334</sup> Even as the global financial system becomes more fractured and bifurcated, central bank immunity enjoys a high level of consensus around the world. Sanctions that would violate that immunity should be approached with great caution, even if imposed against deeply unpopular countries that have inflicted great harm on innocent populations. They are likely to lead to even greater global distrust and

<sup>332</sup> Ruys, Tom (2019), ‘Immunity, Inviolability and Countermeasures – A Closer Look at Non-UN Targeted Sanctions,’ in *Cambridge Handbook of Immunities and International Law*, <sup>supra</sup> note 15.

<sup>333</sup> US Supreme Court, *The Schooner Exchange v McFaddon*, 11 US 7 Cranch 116 116 (1812).

<sup>334</sup> Brunk (Wuerth), *Immunity of Central Bank Assets from Measures of Execution*, <sup>supra</sup> note 15.

disagreement,<sup>335</sup> which may in turn undermine future efforts to use sanctions and indeed international law itself to deter negative conduct and to promote a safe and just world.<sup>336</sup>

---

<sup>335</sup> Many states that condemn Russia's invasion of Ukraine did not vote in favor of a UN General Assembly Resolution on reparations for Ukraine out of a concern with the law of immunity and because many other devastating actions that violated international law have not resulted in the payment of reparations. See UN Eleventh Emergency Special Session, General Assembly Adopts Text Recommending Creation of Register to Document Damages Caused by Russian Federation Aggression against Ukraine, Resuming Emergency Special Session (GA/12470, 14 November 2022).

<sup>336</sup> Notte, Hannah (6 October 2023) 'Russia's Axis of the Sanctioned: Moscow Is Bringing Washington's Enemies Together,' *Foreign Affairs*.

# Economic sanctions and the law of central bank immunity in the United States

Richard Ostrander\*

## 1 Introduction

On Thursday 24 February 2022, Russian forces launched a military invasion of Ukraine. The response from the international community was swift: mere days after the invasion, the United States (US), the European Union (EU), the United Kingdom (UK), and other allies initiated an unprecedented array of coordinated economic sanctions. A wide range of sanctions measures were proposed, debated, and eventually adopted, from a prohibition on imports of key Russian goods such as petroleum products and luxury goods<sup>337</sup> to removing certain Russian banks from the Society for Worldwide Interbank Financial Telecommunications (SWIFT) interbank messaging network.<sup>338</sup> Among the sanctions tools employed by the US were the full blocking or freezing of individual and institutional assets, as well as a prohibition on any transactions involving the Central Bank of Russia, the Russian Ministry of Finance, or the Russian National Wealth Fund.<sup>339</sup>

In the US, key aspects of the legality of blocking, freezing, and seizing foreign assets are governed by the International Emergency Economic Powers Act (IEEPA) of 1977.<sup>340</sup> In cases where those assets are foreign state-owned or held in the name of foreign central banks, sanctions authorized pursuant to IEEPA may affect property that may be subject to the immunity protections of the Foreign Sovereign Immunities Act of 1976 (FSIA).<sup>341</sup> Among other things, the FSIA includes a specific provision conferring attachment immunity protections on property held in central bank accounts at US financial institutions, including the Federal Reserve Bank of New York (New York Fed).

---

\* General Counsel and Head of the Legal & Compliance Group at the Federal Reserve Bank of New York. Raj Bhargava, Michele Kalstein, Katherine Landy and Brett Phillips contributed to this paper.

<sup>337</sup> See Executive Order No 14066, 87 Federal Register 13625 (10 March 2022) (prohibiting petroleum imports); Executive Order No 14068, 87 Federal Register 14381 (15 March 2022) (prohibiting imports of luxury goods).

<sup>338</sup> See Council Regulation (EU) 2022/345 of 1 March 2022 amending Regulation (EU) No 833/2014 concerning restrictive measures in view of Russia's actions destabilising the situation in Ukraine (OJ L 63, 2.3.2022, p. 1); European Commission (2022), "Ukraine: EU agrees to exclude key Russian banks from SWIFT" (Press Release, 2 March), available at [https://ec.europa.eu/commission/presscorner/detail/en/ip\\_22\\_1484](https://ec.europa.eu/commission/presscorner/detail/en/ip_22_1484).

<sup>339</sup> Office of Foreign Assets Control, Dir. 4 Issued Under Executive Order No 14024 (28 February 2022, amend. 19 May 2023); US Department of Treasury (2022), "Treasury prohibits transactions with Central Bank of Russia and imposes sanctions on key sources of Russia's wealth" (Press Release, 28 February), available at <https://home.treasury.gov/news/press-releases/jy0612>.

<sup>340</sup> US Code, Title 50, sections 1701 ff.

<sup>341</sup> US Code, Title 28, sections 1602 ff.

This contribution considers how economic sanctions authorized by IEEPA may interact with FSIA immunity in the US when foreign central bank assets are potentially subject to sanctions. Part 2 analyzes the provisions in the FSIA that confer heightened immunity protections on foreign central bank assets, discusses the public positions that the New York Fed has taken in some cases regarding such protections, and explains certain terrorism-related exceptions to FSIA immunity. Part 3 explores recent events related to assets held by Da Afghanistan Bank (DAB) at the New York Fed in order to illustrate how sanctions authority and the FSIA can be applicable in the context of central bank assets. Part 4 briefly describes the coordinated efforts by the US, the EU, and others to apply sanctions to Russian central bank assets. Part 5 examines asset forfeiture as an alternative avenue for compensating victims of sanctions targets, including in the context of the Russia-Ukraine conflict.

## 2 The Foreign Sovereign Immunities Act and central bank immunity in the United States

The Federal Reserve System, the US central bank, consists of the Board of Governors of the Federal Reserve System, the Federal Open Market Committee, and 12 regional Federal Reserve Banks including the New York Fed. Uniquely among the Reserve Banks, the New York Fed acts as the international operating arm of the Federal Reserve System. In this capacity, the New York Fed, among other activities, maintains accounts for itself and for the US Treasury Department at foreign central banks, including in connection with management of US foreign exchange reserves, and participates in foreign exchange markets on behalf of the Treasury Department and the Federal Reserve System.

In addition, since 1917, the New York Fed has provided banking and financial services to foreign public-sector entities including central banks, monetary authorities, and multilateral financial institutions such as the International Monetary Fund and the World Bank. The New York Fed offers dollar-denominated custody, payment, and investment services to each of these account holders, and many countries maintain a significant portion of their foreign exchange reserves in dollar-denominated assets at the New York Fed.

The FSIA provides two types of immunity: jurisdictional immunity and immunity from attachment and execution. Jurisdictional immunity is immunity from suit in US courts. A foreign entity that enjoys jurisdictional immunity cannot be forced to defend itself in a lawsuit brought in a US court (other than those minimal actions needed to establish its immunity). Immunity from attachment and execution is immunity from the process by which a court orders the seizure and/or transfer of property. Immunity from attachment and execution may protect a foreign entity's assets from being used by judgment creditors to satisfy a judgment, even though the foreign entity may have litigated and lost a suit in a US court.

Attachment and execution are the primary legal means for a judgment creditor to take a judgment debtor's property to satisfy a judgment against the judgment debtor. In many cases of judgments issued against a foreign government, judgment creditors



seek to attach assets of agencies or instrumentalities of the foreign government, including its central bank, even though these entities were not parties to the underlying action.

Together, Sections 1609 through 1611 of the FSIA govern the attachment and execution immunity protections that apply to the property of foreign states held in the US, with specific protections for the property of foreign central banks. Read together, these sections show that Congress intended to confer clear and unambiguous legal protections on foreign central bank assets. Indeed, the legislative history of the FSIA indicates that Congress was concerned that if foreign central bank property in the US were left vulnerable to attachment or execution, deposits of central bank reserves in the US would be discouraged and, by implication, the stability of the international financial system undermined.<sup>342</sup> Moreover, Congress worried that permitting execution against central bank reserves without explicit waiver could cause significant foreign relations problems.<sup>343</sup>

Section 1609 establishes a general presumption of sovereign immunity from attachment or execution for foreign states.<sup>344</sup> Section 1610 enumerates exceptions to this general presumption of immunity, including exceptions for attachment or execution against the property of a foreign state that is used for commercial activity in the US, or where the foreign state has waived immunity from attachment or execution.<sup>345</sup> Section 1611(b)(1) is specifically directed at central banks, and provides immunity from attachment or execution to all property “of a foreign central bank or monetary authority held for its own account”,<sup>346</sup> the exceptions to sovereign immunity carved out by Section 1610 notwithstanding.

Section 1611(b) immunity is subject to two requirements. First, the entity seeking protection for its assets must be a “central bank” or “monetary authority”, terms that are not defined in the FSIA. Second, the funds for which protection is sought must be “held for [the entity’s] own account.” The US Court of Appeals for the Second Circuit set forth a test to determine whether funds are “held for [an entity’s] own account”: when assets are held in an account in the name of a central bank or monetary authority, the assets are presumed to be immune from attachment under Section 1611(b). However, this presumption may be rebutted by “demonstrating with specificity that the funds are not being used for central banking functions as such functions are normally understood.”<sup>347</sup> Unlike Section 1610, there is no commercial activity exception. Courts have recognized that traditional central banking activity may appear commercial in nature, and this does not affect the immunity protections set forth in

---

<sup>342</sup> See House of Representatives Report No 94-1487 (1976), p. 31, reprinted in 1976 U.S.C.C.A.N. 6604, 6630; Letter from Charles N. Brower, US Department of State Acting Legal Advisor, to Elliott L. Richardson, US Attorney General (23 July 1973), quoted in Ernest T. Patrikis (1982), “Foreign Central Bank Property: Immunity from Attachment in the United States”, *University of Illinois Law Review*, p. 270.

<sup>343</sup> See House of Representatives Report No 94-1487 (1976), supra (n 6), p. 31.

<sup>344</sup> US Code, Title 28, section 1609.

<sup>345</sup> *ibid.*, section 1610(a).

<sup>346</sup> *ibid.*, section 1611(b)(1).

<sup>347</sup> *NML Capital, Ltd. v. Banco Central de la República Argentina*, 652 F.3d 172, 197 (2d Cir. 2011).

Section 1611(b)(1).<sup>348</sup> In addition, the relationship between a central bank or monetary authority and its parent state is immaterial; unless there is a final ruling by a court that the parent government is the alter ego of the central bank or monetary authority, the property of the foreign central bank or monetary authority qualifies for immunity regardless of the degree of independence.<sup>349</sup>

The FSIA permits a central bank or monetary authority, or its parent government, to waive immunity from attachment and execution if such waiver is explicit, clear and unambiguous.<sup>350</sup> A parent government can only waive immunity for its central bank or monetary authority where it specifically mentions the central bank or monetary authority, or the particular assets in question.<sup>351</sup> Section 1610 of the FSIA permits foreign states to waive immunity from prejudgment attachment, but Section 1611(b) does not permit a waiver of immunity from prejudgment attachment for central bank assets.<sup>352</sup>

As part of the US central bank and one of the largest custodians of foreign official reserves in the world, the New York Fed has a substantial interest in promoting both a stable legal environment for foreign central bank assets and clear and certain central bank immunity law. As such, the New York Fed occasionally files *amicus curiae*, or "friend of the court", briefs in litigation matters involving the scope of central bank immunity under Section 1611(b)(1). For example, the New York Fed filed such an amicus brief<sup>353</sup> in 2011 in the Second Circuit appeal of *NML Capital, Ltd. v Banco Central de la República Argentina*.<sup>354</sup> In *NML Capital*, holders of defaulted bonds issued by the Republic of Argentina obtained judgments against the Republic of Argentina in a US district court, then sought to attach the reserves of the Central Bank of Argentina on deposit at the New York Fed to satisfy those judgments.<sup>355</sup> The district court allowed the attachment. The Second Circuit reversed, holding that the account at the New York Fed was the property of the central bank, not the parent government, and was immune from attachment under Section 1611(b).

Over time, Congress has introduced a number of modifications or exceptions to FSIA immunity, including in connection with terrorism-related activity. In particular, the Terrorism Risk Insurance Act of 2002 (TRIA)<sup>356</sup> amended the FSIA to permit attachment of blocked assets of a terrorist party ("a terrorist, a terrorist organization [...] or a foreign state designated as a state sponsor of terrorism"), or of an agency or instrumentality of a terrorist party, to satisfy an award of compensatory damages.<sup>357</sup>

---

<sup>348</sup> See, e.g., *Preble-Rish Haiti, S.A. v. Republic of Haiti*, 558 F. Supp. 3d 155, 159-60 (S.D.N.Y. 2021); *Cont'l Transfert Technique, Ltd. v. Fed. Gov't of Nigeria*, No 08-cv-2026, 2019 WL 3562069, p. 17-19 (D.D.C. 6 August 2019); *Weston Compagnie de Fin. Et D'Investissement, S.A. v. La Republica del Ecuador*, 823 F. Supp. 1106, 1113 (S.D.N.Y. 1993).

<sup>349</sup> *NML Capital, Ltd.*, *supra* (n 11), p. 190.

<sup>350</sup> *ibid.*, p. 195.

<sup>351</sup> *ibid.*, pp. 195-96.

<sup>352</sup> See US Code, Title 28, section 1610(d); *Weston*, 823 F. Supp. p. 1111.

<sup>353</sup> 2010 WL 3032829 (C.A. 2) (Appellate Brief) (23 July 2010).

<sup>354</sup> *NML Capital, Ltd.*, *supra* (n 11).

<sup>355</sup> See *EM Ltd. v. Republic of Argentina*, 382 F.3d 291, 292-94 (2d Cir. 2004).

<sup>356</sup> Terrorism Risk Insurance Act of 2002 (TRIA), Public Law No 107-297, 116 Stat. 2322 (2002) (codified as US Code, Title 28, section 1610).

<sup>357</sup> *ibid.*, section 201(a).

A party seeking to execute against assets under this TRIA exception must show that (i) they have obtained a judgment against a terrorist party, (ii) on a claim based on an act of terrorism or an act for which a terrorist party is not immune under certain other provisions of the FSIA, which they seek to satisfy with the (iii) blocked assets, (iv) of that terrorist, terrorist party, or their agency or instrumentality, (v) to the extent of only their compensatory damages. Importantly, the exception applies only to “blocked assets,” which is defined in TRIA to include “any asset seized or frozen by the United States [...] under sections 202 and 203 of the [IEEPA].”<sup>358</sup> This definition captures many or most assets blocked under US economic sanctions programs. With respect to the property of entities that are alleged to be agencies and instrumentalities of a terrorist party, because TRIA does not specifically define the terms “agency” or “instrumentality,” the Second Circuit has construed those words according to their ordinary meanings.<sup>359</sup>

TRIA is not the only statutory mechanism by which Congress has created an exception to the FSIA. Enacted in 2016, the Justice Against Sponsors of Terrorism Act (JASTA) removes a foreign state’s jurisdictional immunity for injuries to property or persons that occurred in the US if such injury was caused by (i) an act of “international terrorism” in the US or (ii) a tortious act of the foreign state regardless of where the act took place.<sup>360</sup> It is possible that a plaintiff could attempt to assert under JASTA a cause of action against a central bank or monetary authority as an “agency or instrumentality of a foreign state.”

In effect, JASTA serves to create liability for persons, including corporations, associations, and other private entities, and possibly central banks and monetary authorities, who aided and abetted, or conspired, in an act of international terrorism. Initially passed to aid families of victims of the September 11 terrorist attacks, JASTA is still the subject of legislative amendment efforts today, with one recent proposal aiming to expand JASTA exceptions to FSIA immunity and altogether abrogate attachment and execution immunity for foreign states and their agencies and instrumentalities in cases arising from terrorist attacks that kill US citizens on US soil.<sup>361</sup>

### 3 Case study of Da Afghanistan Bank: executive sanctions authority and interplay with terrorism exceptions to the FSIA

In August 2021, the Taliban completed a forcible takeover of Afghanistan and its capital city Kabul. US plaintiffs with judgments or claims against the Taliban have attempted to attach the assets of DAB, which has been the central bank of Afghanistan

---

<sup>358</sup> *ibid.*, section 201(d)(2)(A).

<sup>359</sup> *Kirschenbaum v. 650 Fifth Ave. & Related Properties*, 830 F.3d 107, 135 (2d Cir. 2016).

<sup>360</sup> Justice Against Sponsors of Terrorism Act (JASTA), Public Law No 114-222, section 3(a), 130 Stat. 853 (codified as US Code, Title 28, section 1605B).

<sup>361</sup> Chuck Grassley (2023), “Senator, Grassley, colleagues introduce bill to strengthen 9/11 victims law” (Press Release, 22 June), available at <https://www.grassley.senate.gov/news/news-releases/grassley-colleagues-introduce-bill-to-strengthen-9/11-victims-law>.

since its founding in 1939.<sup>362</sup> These litigation efforts have focused on DAB assets held at the New York Fed and have raised a number of interrelated legal issues, including questions around certain statutory exceptions to FSIA attachment immunity and the use of executive orders to freeze central bank assets. For example, victims of the terrorist attacks of 11 September 2001 who have obtained default judgments against the Taliban have sought to enforce their judgments using DAB's accounts at the New York Fed, through the provision of TRIA discussed above, specifically arguing that DAB itself is an agency or instrumentality of the Taliban.

### 3.1 Executive authority under the International Emergency Economic Powers Act

On 11 February 2022, amidst the ongoing litigation attempts to attach DAB assets, President Biden issued Executive Order 14064, titled "Protecting Certain Property of Da Afghanistan Bank for the Benefit of the People of Afghanistan" (Executive Order).<sup>363</sup> In recognition of the "unusual and extraordinary threat to the national security and foreign policy of the United States" posed by the "widespread humanitarian crisis in Afghanistan", and finding the preservation of certain property of DAB held by US financial institutions to be "of the utmost importance to addressing this national emergency and the welfare of the people of Afghanistan", the Executive Order blocked all DAB assets in the US, including those at the New York Fed.<sup>364</sup>

The Executive Order was issued pursuant to IEEPA and related authorities such as the National Emergencies Act. IEEPA, enacted in 1977, empowers the President to freeze foreign-owned assets, including the property of foreign states, based on an executive declaration of a "national emergency".<sup>365</sup> The statute provides that the President may make such a declaration when dealing with "any unusual and extraordinary threat, which has its source in whole or substantial part outside the United States, to the national security, foreign policy, or economy of the United States."<sup>366</sup> IEEPA provides the modern statutory basis for most US sanctions programs, including sanctions imposed on Russia for its aggression in Ukraine. Specifically, upon declaring a national emergency, IEEPA authorizes the President to "prevent or prohibit [...] dealing in [...] or transactions involving [...] any property in which any foreign country or a national thereof has any interest by any person, or with respect to any property, subject to the jurisdiction of the United States."<sup>367</sup> Note that while blocking or freezing assets pursuant to this provision is a common practice under IEEPA and related authorities, IEEPA only permits the President to confiscate foreign-

---

<sup>362</sup> *In re Terrorist Attacks on September 11, 2001*, No 03-MDL-01570, 2023 WL 2138691, p. 3 (S.D.N.Y. 21 February 2023) [hereinafter *In re 9/11*]. Despite the takeover, no country in the world recognizes the Taliban regime as the government of Afghanistan. *ibid.*

<sup>363</sup> Executive Order No 14064, 87 Federal Register 8391 (15 February 2022).

<sup>364</sup> *ibid.*

<sup>365</sup> US Code, Title 50, sections 1701 ff.

<sup>366</sup> *ibid.*, section 1701(a).

<sup>367</sup> *ibid.*, section 1702(a)(1)(B).

owned property “when the United States is engaged in armed hostilities or has been attacked by a foreign country or foreign nationals.”<sup>368</sup>

The Executive Order, which expressly acknowledged the ongoing litigation attempts to attach assets held by DAB, laid the groundwork for a mechanism by which approximately half of the assets would remain at the New York Fed, and the other half would be “transferred for the benefit of the Afghan people in view of the urgent humanitarian and economic crisis in Afghanistan.”<sup>369</sup> On the same date as the Executive Order, the Treasury Department’s Office of Foreign Assets Control (OFAC) issued License No DABRESERVES-EO-2022-886895-1 (OFAC License) which, among other things, directed the New York Fed, upon instruction from individual(s) certified by the Secretary of State pursuant to Section 25B of the Federal Reserve Act as having authority to receive, control, or dispose of property from or for the account of DAB, to transfer USD 3.5 billion from an identified DAB account at the New York Fed to an international financing mechanism to address the humanitarian crisis.<sup>370</sup> This USD 3.5 billion was subsequently transferred from the DAB account at the New York Fed to the newly created, Swiss-based Fund for the Afghan People (Afghan Fund).<sup>371</sup>

The assets transferred to the Afghan Fund remained immune from attachment because, as noted above, TRIA authorizes the attachment only of “blocked assets,” which are defined as assets “seized or frozen by the United States.”<sup>372</sup> The Second Circuit has determined that assets are “blocked” for the purposes of TRIA only if they are subject to a freezing of assets that imposes an “across-the-board prohibition against transfers or transactions of any kind with regards to the property”, and assets subject to OFAC license are not subject to this type of prohibition.<sup>373</sup>

The assets subject to the OFAC license were transferred to the Afghan Fund upon instructions from two individuals certified pursuant to Section 25B of the Federal Reserve Act.<sup>374</sup> Section 25B authorizes the Secretary of State to issue a certification to a Reserve Bank regarding the authority of one or more individuals to control and dispose of central bank property in the US when a representative of the foreign state recognized by the Secretary, typically the accredited ambassador to the US, has delivered a parallel certification to the Secretary.<sup>375</sup> In the DAB case, because the State Department had delivered a Section 25B certification to the New York Fed and the OFAC license expressly contemplated transfer of licensed assets on the instruction of 25B-certified individuals, the licensed portion of the central bank’s

---

<sup>368</sup> *ibid.*, section 1702(a)(1)(C).

<sup>369</sup> *In re 9/11*, *supra* (n 26); Statement of Interest of the United States of America p. 4, *John Does 1 Through 7 v. The Taliban et al.*, No 1:20-mc-00740-KPF (S.D.N.Y. 11 February 2022), ECF No 49 (Statement of Interest).

<sup>370</sup> *ibid.*, p. 2.

<sup>371</sup> Fund for the Afghan People, available at <https://www.afghanfund.ch/>.

<sup>372</sup> TRIA, sections 201(a), 201(d)(2)(A).

<sup>373</sup> See Statement of Interest, *supra* (n 33), p. 16-19 (quoting *Weinstein v. Islamic Repub. of Iran*, 299 F. Supp. 2d 63, 75 (E.D.N.Y. 2004) (internal quotations omitted)); *Bank of New York v. Rubin*, 484 F.3d 149, 150 (2d Cir. 2007) (adopting the “persuasive analysis” of Weinstein).

<sup>374</sup> See Joint Statement by US Treasury and State Department (2022), “The United States and partners announce establishment of Fund for the People of Afghanistan” (Press Release, 14 September), available at <https://home.treasury.gov/news/press-releases/jy0947>.

<sup>375</sup> US Code, Title 12, section 632.

blocked property was able to move to the Afghan Fund using this statutory mechanism.

### 3.2 Litigation involving statutory exceptions to the FSIA

As noted above, in recent multidistrict litigation in federal court, plaintiffs groups with judgments against the Taliban arising from various acts of terrorism, including the terrorist attacks on 11 September 2001, moved to attach the remaining DAB assets at the New York Fed through the TRIA exception.<sup>376</sup> On 21 February 2023, the US District Court for the Southern District of New York held that DAB is a central bank entitled to jurisdictional immunity under the FSIA and that the court is constitutionally constrained from permitting creditors to seize DAB funds. The Southern District opined that “[f]inding that the Taliban controls DAB or can use DAB to advance its goals implies that the Taliban is Afghanistan’s government. The Constitution vests this authority to recognize governments in the Executive Branch alone.”<sup>377</sup> The judgment creditor plaintiffs have appealed to the Second Circuit.

The Southern District came to a similar decision days later in *Owens v Taliban*, where victims and family members of victims of the 7 August 1998 terrorist bombings of the US embassies in Dar es Salaam, Tanzania and Nairobi, Kenya by al Qaeda who had recently filed claims against the Taliban sought to confirm a pre-judgment attachment order against DAB accounts at the New York Fed.<sup>378</sup> The plaintiffs argued that the Taliban’s financial support for al Qaeda, combined with the influence that the Taliban exerted on DAB, including installing its own officials at DAB, controlling DAB’s decision-making, replacing Afghanistan’s central banking laws with traditional Islamic banking, and scaling back DAB’s anti-money laundering and anti-terrorism financing efforts, demonstrated that DAB assets should be used to satisfy judgments under TRIA.<sup>379</sup> The Southern District held that while the alleged loosening of controls at DAB enabled the Taliban to “engage in financial misconduct without interference from DAB”, that does not mean that “DAB is currently operating as an arm of the Taliban.”<sup>380</sup> But even if the facts had indicated thus, the court concluded that it could not find the Taliban to be the government of Afghanistan since, through the executive order and its Statement of Interest filed in the multidistrict litigation, the US government “reaffirmed DAB’s status as a sovereign agency or instrumentality entitled to immunity notwithstanding a non-state terrorist entity’s efforts to assert control over it.”<sup>381</sup>

In other contexts, plaintiffs have managed to successfully use the TRIA exception to attach central bank assets. For example, in *Harrison v Republic of Sudan*, plaintiffs obtained a default judgment against the Republic of Sudan, which the US government at the time had designated a state sponsor of terrorism for providing material support to al Qaeda, the organization responsible for the attack on the USS Cole that injured

---

<sup>376</sup> See In re 9/11, supra (n 26).

<sup>377</sup> *ibid.*, p. 11.

<sup>378</sup> *Owens v Taliban*, No 22-cv-1949, 2023 WL 2214887 (S.D.N.Y. 24 February 2023).

<sup>379</sup> *ibid.*, p. 2.

<sup>380</sup> *ibid.*, p. 5.

<sup>381</sup> *ibid.*, p. 6.

and killed plaintiffs and plaintiffs' spouses.<sup>382</sup> In order to partially satisfy the amounts owned under the judgment, the Southern District in 2016 relied on the TRIA exception to order the turnover of Central Bank of Sudan assets held at the New York Fed,<sup>383</sup> and in 2018 denied the central bank's appeal of a turnover order issued regarding central bank assets held at a commercial bank in New York.<sup>384</sup> The court specifically noted that "[t]he TRIA applies '[n]otwithstanding any other provision of law.' The Supreme Court, relying on this phrase, observed that the 'FSIA's central-bank immunity provision [...] limits [parts of section] 1610, but not the TRIA.' Because the TRIA applies here [...] the central-bank immunity provision does not apply."<sup>385</sup>

## 4 Russian Central Bank assets and international sanctions

On 28 February 2022, the US, EU, UK, and other allies all announced prohibitions on transactions involving the Central Bank of Russia and other Russian sovereign entities, with some subtle differences in language. The EU announced a prohibition on "transactions related to the management of reserves as well as of assets of the Central Bank of Russia", to which EU Member States may grant exemptions.<sup>386</sup> At the same time, the UK prohibited its nationals from "provid[ing] financial services" to, including activities "relating to the reserves or assets of", the Central Bank of Russia, the Russian Ministry of Finance, or the Russian National Wealth Fund.<sup>387</sup>

The US announced the most comprehensive restriction, imposing a full prohibition on "any transaction involving" the Central Bank of Russia, the Russian Ministry of Finance, or the Russian National Wealth Fund, including any transfer of assets to such entities or any foreign exchange transaction for or on behalf of these three entities.<sup>388</sup> While not a full block or asset freeze of Russian central bank assets, this prohibition effectively prevents Russian central bank assets in existing accounts from moving by prohibiting US persons, including the New York Fed, from executing transaction instructions received from the Central Bank of Russia.

Under existing sanctions law, these assets could remain effectively inaccessible for a long period of time, but likely could not be seized or confiscated by the US government. However, recent legislative proposals in the US would grant new statutory authority for the President to seize Russian central bank assets. The most recent of these bills, the Rebuilding Economic Prosperity and Opportunity (REPO) for Ukrainians Act, was proposed in June 2023 and would give the President the authority to confiscate

---

<sup>382</sup> See *Harrison v. Republic of Sudan*, 882 F. Supp. 2d 23 (D.D.C 2012).

<sup>383</sup> Stipulation of Order and Judgment Concerning Turnover of Blocked Property, *Harrison v. Republic of Sudan*, No 13-cv-03127-PKC, Docket No 495 (S.D.N.Y. 29 November 2016).

<sup>384</sup> *Harrison v. Republic of Sudan*, 309 F. Supp. 3d 46 (S.D.N.Y. 2018).

<sup>385</sup> *ibid.* p. 52 (citing TRIA, section 201(a) and *Bank Markazi v. Peterson*, 136 S.Ct. 1310, 1318 n.2 (2016)).

<sup>386</sup> Council Regulation (EU) 2022/334 of 28 February 2022 amending Council Regulation (EU) No 833/2014 concerning restrictive measures in view of Russia's actions destabilising the situation in Ukraine (OJ L 57, 28.2.2022, p. 1).

<sup>387</sup> See HM Treasury & Office of Financial Sanctions Implementation (2022), "UK statement on further economic sanctions targeted at the Central Bank of the Russian Federation" (Press Release, 28 February), available at <https://www.gov.uk/government/news/uk-statement-on-further-economic-sanctions-targeted-at-the-central-bank-of-the-russian-federation>.

<sup>388</sup> See Office of Foreign Assets Control, Dir. 4 Issued Under Executive Order No 14024, *supra* (n 3).

Russian sovereign assets subject to sanctions in the US, expressly including central bank assets, and transfer them to assist in Ukraine's reconstruction efforts.<sup>389</sup> The bill further prohibits the release of funds to sanctioned Russian entities until Russia withdraws from Ukraine and agrees to provide compensation for harm caused by war, and instructs the President to work with allies and partners to establish an international compensation mechanism to transfer confiscated or frozen Russian sovereign assets to assist Ukraine.

## 5 Using asset forfeiture for victim compensation

While new legislation likely would be required to provide the authority to seize sanctioned assets, there are other areas of law where assets can be seized for use in compensating victims of wrongful acts. Criminal asset forfeiture, an action brought as a part of a criminal prosecution of a defendant and that requires a criminal indictment or conviction, is used in the US to compensate victims of crimes.<sup>390</sup> Criminal forfeiture is limited to the property interests of the defendant and is generally limited to property involved in or earned by the particular counts on which the defendant is indicted or convicted.

In May 2023, the US for the first time seized and transferred assets from a Russian oligarch for the reconstruction of Ukraine under asset forfeiture authority.<sup>391</sup> The US Department of Justice announced the seizure of millions of dollars from an account at a US financial institution traceable to businessman Konstantin Malofeyev's sanctions violations after Malofeyev failed to contest charges that he violated sanctions imposed on Russia and provided financing to separatists in Crimea. The USD 5.4 million in forfeited funds, authorized by the Justice Department to be used "in Ukraine to remediate the harms of Russia's unjust war",<sup>392</sup> were transferred to the US Department of State.

---

<sup>389</sup> Senate Foreign Relations Committee (2023), "Risch, Whitehouse, McCaul, Kaptur introduce legislation to repurpose sovereign Russian assets for Ukraine", (Press Release, 15 June), available at <https://www.foreign.senate.gov/press/rep/release/risch-whitehouse-mccaul-kaptur-introduce-legislation-to-repurpose-sovereign-russian-assets-for-ukraine>.

<sup>390</sup> See US Department of Justice (2022), Types of Federal Forfeiture, (17 February), available at <https://www.justice.gov/afms/types-federal-forfeiture>.

<sup>391</sup> US Department of Justice (2022), "Russian oligarch charged with violating U.S. sanctions" (Press Release, 6 April), available at <https://www.justice.gov/opa/pr/russian-oligarch-charged-violating-us-sanctions>; Politi, J., Fleming, S. and Johnston, I. (2023), "US transfers seized assets from sanctions-hit oligarch to send to Ukraine", *Financial Times*, 11 May 2023, available at <https://www.ft.com/content/ef3501bf-c498-4597-bec3-c284daf9ac2b>.

<sup>392</sup> *ibid.*



# Use of the immobilized Russian Central Bank assets to rebuild Ukraine: between political will and legal hurdles

Iryna Bogdanova\*

## 1 Introduction

The current discussion of Ukraine's recovery and reconstruction takes place against the backdrop of the broad and internationally coordinated efforts to sanction Russia and its ruling elites. Given that these sanctions resulted in the assets of the Russian Central Bank and entities under its control being immobilized, the question that immediately springs to one's mind is whether and how can these resources be used to rebuild Ukraine. While the political discussions have abounded in claims that these funds can be used as reparations and the war crimes committed by the Russian army only strengthen this resolve, this might be a thorny path to follow from a legal perspective.

It is against this backdrop that this chapter aims to contribute to both academic and policy debates on the topic. The contribution is structured in the following way. Part 2 is dedicated to the analysis of whether there is a political will among the states that immobilized Russian assets to confiscate or use them. Following this, Part 3 focuses on the discussion of the legality of such a move. For this purpose, the legality of asset confiscation or their temporary use is examined against the background of immunities granted to central bank assets under international law. Subsequently, this part explores possible legal justifications for asset confiscation and their availability.

## 2 Use of the immobilized Russian Central Bank assets to rebuild Ukraine: a slow build-up of a political will?

In the early days of the invasion, Russian Central Bank assets were immobilized in an effort to hamstring Russia's capabilities to wage war.<sup>393</sup> According to various

---

\* International law scholar from Ukraine who currently holds a position as a postdoctoral researcher and is based at the World Trade Institute, University of Bern.

<sup>393</sup> For example, the European Union prohibited all transactions with the Central Bank of Russia related to the management of its reserves and assets. Council of the European Union (2022), "Russia's military aggression against Ukraine: Council imposes sanctions on 26 persons and one entity", *Press release*, <https://www.consilium.europa.eu/en/press/press-releases/2022/02/28/russia-s-military-aggression-against-ukraine-council-imposes-sanctions-on-26-persons-and-one-entity/>.

estimates, the value of the immobilized assets exceeds USD 300 billion.<sup>394</sup> Since then, the discussion on confiscating and using these assets for Ukraine's reconstruction has progressed along two prongs. The first prong is a vigorous academic debate, which continues among scholars on whether confiscation of Russian state-owned assets violates international law and if it can be justified. Another trajectory of development is the decisions of individual states or groups of states (i.e., the European Union (EU)) to introduce domestic legislation allowing certain actions with frozen and immobilized Russian assets. In this section, I will briefly outline the developments taking place in the jurisdictions that immobilized Russian Central Bank assets, while in the next section I will turn to the debate on the legality of asset confiscation.

## 2.1 Canada

Canada was the first state that amended its sanctions legislation to allow the confiscation of state-owned and private assets irrespective of whether such assets were acquired legally or illegally.<sup>395</sup> The amended law explicitly stipulates that the confiscated assets can be used for three purposes: "(a) the reconstruction of a foreign state adversely affected by a grave breach of international peace and security; (b) the restoration of international peace and security; and (c) the compensation of victims of a grave breach of international peace and security, gross and systematic human rights violations or acts of significant corruption."<sup>396</sup>

Any such confiscation is a subject of judicial oversight. However, it should be noted that the judge has limited powers and should only determine if: "the property (a) is described in an order made under paragraph 4(1)(b); and (b) is owned by the person referred to in that order or is held or controlled, directly or indirectly, by that person."<sup>397</sup> This low standard of judicial oversight has been already criticized as "a rubber stamp dressed up as the rule of law."<sup>398</sup>

The law leaves many questions without an answer. To illustrate this, it is worth quoting Senator Ratna Omidvar's speech endorsing the amendments: "[b]ig questions need to be asked, such as: Who should receive the assets? Should it be the countries of origin or a country that is seeking restitution, such as Ukraine? Or would it be individual

---

<sup>394</sup> As reported, more than USD 30 billion worth of sanctioned Russians' assets were blocked or frozen; about USD 300 billion worth of Russian Central Bank assets were immobilized; yachts and other vessels as well as luxury real estate were frozen. U.S. Department of the Treasury (2022), "Russian Elites, Proxies, and Oligarchs Task Force Joint Statement", *Press release*, <https://home.treasury.gov/news/press-releases/jy0839>; Hufbauer G.C. and Schott J.J. (2022), "The United States should seize Russian assets for Ukraine's reconstruction", *Peterson Institute for International Economics*, <https://www.piie.com/blogs/realtime-economic-issues-watch/united-states-should-seize-russian-assets-ukraine>.

<sup>395</sup> To be more specific, Bill C-19 amends certain provisions of the Special Economic Measures Act, a law which regulates the imposition of unilateral economic sanctions by Canada. According to these amendments, a property owned or controlled by (i) a foreign state, (ii) any person in that foreign state, or (iii) a national of that foreign state who does not ordinarily reside in Canada can be seized. *Special Economic Measures Act*, S.C. 1992, c. 17.

<sup>396</sup> *ibid.*

<sup>397</sup> *ibid.*

<sup>398</sup> Dornbierer A. (2023), "From sanctions to confiscation while upholding the rule of law", *Basel Institute on Governance Working Paper 42*, p. 18.

victims as opposed to communities or nation states? How would the assets be distributed? What accountability mechanisms are needed?”<sup>399</sup>

In December 2022, Canada initiated the first process to confiscate the assets of Granite Capital Holdings Ltd., a company owned by sanctioned Russian oligarch Roman Abramovich.<sup>400</sup> In June this year, the Canadian government ordered the seizure of a Russian-registered cargo aircraft “believed to be owned” by a subsidiary of two sanctioned Russian entities.<sup>401</sup>

## 2.2 United States

The war in Ukraine provoked a heated debate among United States (US) intellectuals and policy-makers on the possibility of confiscating frozen Russian assets. Some scholars, such as, Professor Laurence H. Tribe, argue that the existing statutes grant the President the authority to seize and use frozen assets for the benefit of war-torn Ukraine,<sup>402</sup> while other commentators call for new legislation specifically tailored for this purpose.<sup>403</sup> The third view is to oppose any asset confiscation, namely either based on the lack of statutory powers to follow this path<sup>404</sup> or based on the policy considerations (i.e., this move might undermine the US role in the global economy)<sup>405</sup>.

Moreover, in the first months of the war, five bills proposing diverse approaches to asset confiscation were introduced.<sup>406</sup> None of these bills was passed. More recently, the Rebuilding Economic Prosperity and Opportunity for Ukrainians Act was introduced to Congress and, if adopted, it would authorize the confiscation of Russian sovereign assets and their transfer to Ukraine without any judicial oversight.<sup>407</sup>

---

<sup>399</sup> Senator Ratna Omidvar (2022), *Bill C-19: The Frozen Assets Repurposing Act and the Effective and Accountable Charities Act are Included in the BIA*, Speech, <https://www.ratnaomidvar.ca/bill-c19-the-frozen-assets-repurposing-act-and-the-effective-and-accountable-charities-act-are-included-in-the-bia-2/>.

<sup>400</sup> Global Affairs Canada (2022), “Canada starts first process to seize and pursue the forfeiture of assets of sanctioned Russian oligarch”, *News release*, <https://www.canada.ca/en/global-affairs/news/2022/12/canada-starts-first-process-to-seize-and-pursue-the-forfeiture-of-assets-of-sanctioned-russian-oligarch.html>.

<sup>401</sup> Global Affairs Canada (2023), “Government of Canada orders seizure of Russian-registered cargo aircraft at Toronto Pearson Airport”, *News release*, <https://www.canada.ca/en/global-affairs/news/2023/06/government-of-canada-orders-seizure-of-russian-registered-cargo-aircraft-at-toronto-pearson-airport.html>.

<sup>402</sup> Tribe L. H. and Lewin J. (2022), “\$100 Billion. Russia’s Treasure in the U.S. Should Be Turned Against Putin”, *The New York Times*, <https://www.nytimes.com/2022/04/15/opinion/russia-war-currency-reserves.html>; Tribe L. H. (2022), “Does American Law Currently Authorize the President to Seize Sovereign Russian Assets?”, *Lawfare*, <https://www.lawfareblog.com/does-american-law-currently-authorize-president-seize-sovereign-russian-assets>.

<sup>403</sup> Hufbauer and Schott (2022) (n 2).

<sup>404</sup> Boyle A. (2022), “Why Proposals for U.S. to Liquidate and Use Russian Central Bank Assets Are Legally Unavailable”, *Just Security*, <https://www.justsecurity.org/81165/why-proposals-for-u-s-to-liquidate-and-use-russian-central-bank-assets-are-legally-unavailable/>; Stephan P. (2022), “Giving Russian Assets to Ukraine – Freezing Is Not Seizing”, *Lawfare*, <https://www.lawfareblog.com/giving-russian-assets-ukraine-freezing-not-seizing>.

<sup>405</sup> Anderson S. R. and Keitner C. (2022), “The Legal Challenges Presented by Seizing Frozen Russian Assets”, *Lawfare*, <https://www.lawfareblog.com/legal-challenges-presented-seizing-frozen-russian-assets>.

<sup>406</sup> Asset Seizure for Ukraine Reconstruction Act (H.R.6930); Repurposing Elite Luxuries into Emergency Funds for Ukraine Act (S.3936); Oligarch Asset Forfeiture Act (H.R.7086); Yachts for Ukraine Act (H.R.7187); Oligarch Assets for Ukrainian Victory Act of 2022 (H.R.8156).

<sup>407</sup> Rebuilding Economic Prosperity and Opportunity for Ukrainians Act (H.R.4175), 118th Congress (2023-2024), <https://www.congress.gov/bill/118th-congress/house-bill/4175?s=1&r=15>.

## 2.3 United Kingdom

In June 2023, before hosting the Ukraine Recovery Conference, the United Kingdom's government announced new legislation that enables it to keep sanctions against Russia in place until compensation is paid to Ukraine.<sup>408</sup> Also, new legislation allows sanctioned individuals to donate their frozen assets for Ukraine's reconstruction if they wish to do so.<sup>409</sup>

## 2.4 European Union

At the European level, two initiatives have gained traction. The first of these initiatives is a proposal to criminalize violation of the EU's sanctions (restrictive measures) and confiscate assets involved in sanctions violations. According to the draft directive, sanctions violation would transform a frozen asset into proceeds of crime, meaning that the Member States would be able to confiscate such assets.<sup>410</sup> To enable confiscation of the frozen assets as a penalty for EU sanctions violation, the EU has to undertake the following three steps: (i) recognize the violation of EU restrictive measures as a serious crime under Article 83 of the Treaty on the Functioning of the European Union (TFEU);<sup>411</sup> (ii) harmonize the definitions and penalties for violation of EU restrictive measures;<sup>412</sup> and (iii) amend asset recovery rules to allow confiscation of the assets implicated in violations of EU restrictive measures.<sup>413</sup> As of the time of writing, the first step has been undertaken, and the EU directives allowing subsequent two steps are under consideration.

The second EU proposal is to use immobilized Russian Central Bank assets to generate profit that could be transferred to Ukraine in the fulfilment of the Russian obligation to pay reparations. In November 2022, the European Commission presented options for using immobilized assets for the reconstruction of Ukraine.<sup>414</sup> The official press release presents the short-term and long-term solutions.<sup>415</sup> In the short term, the EU intends to set up a structure to manage the immobilized public

---

<sup>408</sup> Foreign, Commonwealth & Development Office, HM Treasury, Home Office, The Rt Hon Suella Braverman KC MP, The Rt Hon Jeremy Hunt MP, and The Rt Hon James Cleverly MP (2023), "New legislation allows Russian sanctions to remain until compensation is paid to Kyiv", *Press release*, <https://www.gov.uk/government/news/new-legislation-allows-russian-sanctions-to-remain-until-compensation-is-paid-to-kyiv#:~:text=The%20UK%20government%20is%20taking,compensation%20is%20paid%20to%20Ukraine>.

<sup>409</sup> *ibid.*

<sup>410</sup> Proposal for a Directive of the European Parliament and of the Council on the definition of criminal offences and penalties for the violation of Union restrictive measures (COM(2022) 684 final) (Proposal for a Directive of the European Parliament and of the Council).

<sup>411</sup> On November 28, 2022, the Council of the European Union unanimously decided to add the violation of EU restrictive measures to the areas of 'particularly serious crime with a cross-border dimension' set out in Article 83(1) TFEU. Council Decision (EU) 2022/2332 of 28 November 2022 on identifying the violation of Union restrictive measures as an area of crime that meets the criteria specified in Article 83(1) of the Treaty on the Functioning of the European Union (OJ L 308, 29.11.2022, p. 18).

<sup>412</sup> Proposal for a Directive of the European Parliament and of the Council (2022) (n 18).

<sup>413</sup> Proposal for a Directive of the European Parliament and of the Council on asset recovery and confiscation (COM(2022) 245 final).

<sup>414</sup> European Commission (2022), "Ukraine: Commission presents options to make sure that Russia pays for its crimes", *Press release*, [https://ec.europa.eu/commission/presscorner/detail/en/ip\\_22\\_7311](https://ec.europa.eu/commission/presscorner/detail/en/ip_22_7311).

<sup>415</sup> *ibid.*

funds, invest them and use the proceeds in favour of Ukraine.<sup>416</sup> In the long term, it is expected that once the sanctions are lifted, the Russian Central Bank assets will be returned.<sup>417</sup> However, such a return would need to be considered in the context of any future peace agreement and reparation claims could be offset against those held assets.<sup>418</sup>

A paper presented by the Ad hoc Working Party on Frozen Assets earlier this year further elaborates on this approach of cautious balance. It outlined the option of temporary active management – through ‘sound investment’ – of immobilized assets of the Central Bank of Russia and entities under its control.<sup>419</sup> It was explicitly focused on the possibility of using liquid assets.<sup>420</sup> From the legal perspective, the paper discusses the relationship between the proposed ‘active management’ and state immunity as well as the legal basis under the EU law that could be used to introduce the principle of active management.<sup>421</sup>

The idea was met with strong opposition expressed by some EU Member States and the European Central Bank prompting further discussions at the EU level.<sup>422</sup> As of the time of writing, a new proposal that is being deliberated puts forward an idea of taxing proceeds generated from the immobilized Russian assets with the subsequent transfer of such tax profits to Ukraine.<sup>423</sup>

## 2.5 Switzerland

In response to the EU’s debate, Swiss authorities that immobilized CHF 7.4 billion Russian Central Bank assets responded: “[i]n the EU there are ongoing discussions on whether assets of the Russian Central Bank should be invested and the proceeds used for the reconstruction of Ukraine. Switzerland is following these discussions closely.”<sup>424</sup>

## 2.6 G7 Foreign Ministers’ Communiqué

In April 2023, the G7 Foreign Ministers’ Communiqué declared that “[w]e [G7 Members] are determined, consistent with our respective legal systems, that Russia’s sovereign assets in our jurisdictions will remain immobilized until there is a resolution

---

<sup>416</sup> *ibid.*

<sup>417</sup> *ibid.*

<sup>418</sup> *ibid.*

<sup>419</sup> Council of the European Union (2023), *Non-paper on the generation of resources to support Ukraine from immobilised Russian assets*, Doc. WK 3926/2023 INIT. The leaked version was published by POLITICO, <https://www.politico.eu/article/eu-looks-at-investing-vladimir-putin-russia-state-assets-to-raise-cash-for-ukraine/>

<sup>420</sup> *ibid.*

<sup>421</sup> *ibid.*

<sup>422</sup> Tamma P. (2023), “EU plays for time on plans to use Russian frozen assets to rebuild Ukraine”, POLITICO, <https://www.politico.eu/article/commission-charts-cautious-way-forward-on-russian-frozen-assets/>.

<sup>423</sup> *ibid.*

<sup>424</sup> The Federal Council (2023), “CHF 7.4 billion of Russian central bank assets held in Switzerland”, *Press release*, <https://www.admin.ch/gov/en/start/documentation/media-releases.msg-id-95045.html>.

of the conflict that addresses Russia's violation of Ukraine's sovereignty and territorial integrity. Any resolution to the conflict must ensure Russia pays for the damage it has caused."<sup>425</sup> This statement underlines that G7 Members have not reached any decision regarding the confiscation of the Russian Central Bank assets. There are a number of reasons for this. Firstly, states are concerned that confiscation may send a wrong signal to other states, i.e., other states might perceive these countries as unsafe destinations for parking their foreign exchange reserves. For the US, it also means that foreign central banks would be discouraged from using USD as a reserve currency.<sup>426</sup> As a result, the dollar-based financial system might be under threat, depriving the US of its financial leverage.<sup>427</sup> In this regard, some commentators argue that a concerted move of G7 countries should be a preferred option as it "would deter aggressors but have little other effect, because countries that want to trade in dollars and euros and yen don't have alternate liquid assets to hold."<sup>428</sup> Secondly, states are reluctant to establish a new precedent that might be later used against them. This concern is reflective of a broader state of international affairs that is characterized by the great-power rivalry, which is increasingly infiltrating international relations. In light of the above, any initiative to confiscate central bank assets is taken with a grain, or even a boulder, of salt.

States are hesitant to confiscate Russian Central Bank assets partly due to the fact that the legality of such a move is questionable, and because it might also set a dangerous precedent for the future. In the next section, I discuss the relationship between confiscation or temporary use of immobilized central bank assets and the law of state immunity.

### 3 Legal hurdles preventing confiscation or temporary use of the immobilized Russian Central Bank assets

The immobilization of the Russian Central Bank assets and the ongoing discussion about their possible confiscation have engrossed international legal scholars since the early days of the Russian invasion of Ukraine. From the legal standpoint, this discussion touches upon three areas of international law: the law of economic sanctions, state immunity and state responsibility. To be more specific, the answers to the following legal questions might be definitive for the ongoing debate: what is the

---

<sup>425</sup> G7 (2023), *Foreign Ministers' Communiqué*, <https://www.diplomatie.gouv.fr/en/french-foreign-policy/global-challenges/news/article/g7-japan-2023-foreign-ministers-communique-april-18-2023>.

<sup>426</sup> The often-quoted argument is that confiscation of the Russian Central Bank assets would have a detrimental effect on the United States: this move "could make nations reluctant to keep their reserves in dollars, for fear that in future conflicts the United States and its allies would confiscate the funds." Rappeport A. and Sanger D. E. (2022), "Seizing Russian Assets to Help Ukraine Sets Off White House Debate", *The New York Times*, <https://www.nytimes.com/2022/05/31/us/politics/russia-sanctions-central-bank-assets.html>.

<sup>427</sup> "The domestic and international legal protections that the United States generally extends to foreign assets—and especially foreign state and central bank assets—are a major contributor to the central role that the United States plays in the global economy. Compromising them may not only injure the U.S. economy but also limit the economic tools, such as economic sanctions, that the United States has available to it in the future." Anderson and Keitner (2022) (n 13).

<sup>428</sup> Summers L. H., Zelikow P. D., and Zoellick R. B. (2023), "The moral and legal case for sending Russia's frozen 300 billion to Ukraine", *The Washington Post*, <https://www.washingtonpost.com/opinions/2023/03/20/transfer-russian-frozen-assets-ukraine/>.

exact scope of the immunity from execution as it applies to central bank assets? Can a narrowly defined exception from immunity guarantees be developed for cases like Russia's aggression against Ukraine? Can confiscation or temporary use of the central bank assets qualify as permissible countermeasures?

While the answers to these questions dwell in uncertainty, the heated legal debates persist. This part aims to clarify the ambit of the relevant legal debates by presenting legal arguments supporting divergent views on the abovementioned questions.

### 3.1 State immunity and central bank assets

The main legal obstacle to the confiscation or temporary use of the central bank assets stems from the principle of state immunity that originates in customary international law and embodies jurisdictional immunity (immunity from adjudication) and enforcement immunity (immunity from execution).<sup>429</sup> While the former embodiment of state immunity is not applicable to out-of-court proceedings, the application of the latter to the executive decisions taken not in the context of court proceedings is debatable. For example, Jean-Marc Thouvenin and Victor Grandaubert hold the view that immunity from execution is equal to immunity from any type of constraint.<sup>430</sup> In contrast, Tom Ruys contends that immunity from execution is applicable only in the context of court proceedings.<sup>431</sup>

There is almost universal acceptance that central bank property benefits from the state immunity guarantees.<sup>432</sup> The minimum protection granted to central bank property under the customary international law of state immunity requires that 'property of the central bank or other monetary authority of the state' cannot be put under any form of constraint as a result of a court judgment.<sup>433</sup>

---

<sup>429</sup> Stoll P.-T. (2011), "State Immunity", *Max Planck Encyclopedia of Public International Law* [MPEPIL], <https://opil.ouplaw.com/display/10.1093/law:epil/9780199231690/law-9780199231690-e1106>.

<sup>430</sup> Jean-Marc Thouvenin and Victor Grandaubert argue that the terms 'immunity from execution' ('immunity from enforcement') do not capture the idea behind them, and instead the term 'immunity from constraint' should be used.

Thouvenin J.-M. and Grandaubert V. (2019), "The Material Scope of State Immunity from Execution", in *The Cambridge Handbook of Immunities and International Law*, Ruys T., Angelet N. and Ferro L. (eds), Cambridge University Press.

<sup>431</sup> Ruys T. (2019), "Immunity, Inviolability and Countermeasures – A Closer Look at Non-UN Targeted Sanctions" in *The Cambridge Handbook of Immunities and International Law*, Ruys T., Angelet N. and Ferro L. (eds), Cambridge University Press.

<sup>432</sup> Wuerth I. (2019). "Immunity from Execution of Central Bank Assets", in *The Cambridge Handbook of Immunities and International Law*, Ruys T., Angelet N. and Ferro L. (eds), Cambridge University Press; Fox H. QC and Webb P. (2015), *The Law of State Immunity* (revised and updated 3rd Edition), Oxford University Press.

<sup>433</sup> This conclusion can be reached based on Article 5 and Article 21(1)(c) of the United Nations Convention on Jurisdictional Immunities of States and Their Property (UN Convention on State Immunity) (2004), adopted by the General Assembly of the United Nations on 2 December 2004, but not yet in force. Some legal scholars have even argued that Article 21(1)(c) prohibits the freezing of the central bank assets. For example, Pierre-Emmanuel Dupont has been of the view that freezing of the central bank assets "may be deemed to conflict with rules governing immunities and privileges of foreign States under international law, and in particular of the 2004 UN Convention on Jurisdictional Immunities of States and Their Property, which is widely considered as reflecting customary international law." Dupont P.-E. (2012), "Countermeasures and Collective Security: The Case of the EU Sanctions Against Iran", *Journal of Conflict & Security Law*, Vol. 17 No. 3, pp. 301–336.

This being said, economic sanctions are adopted by the executive branch of a government and they may target assets of the central banks as temporary measures of constraint imposed outside of any court proceedings and, as a rule, do not entail a change of ownership. In light of this, the question that remains without any clear answer is the following: how does state immunity restrain states from freezing central bank assets? The answer to this question hinges on a more general issue mentioned before, namely the application of immunity from execution to the out-of-court proceedings, the matter which remains unsettled in international law.

The Russian invasion of Ukraine has reinvigorated the debate on the legality of unilateral economic sanctions that entail freezing or immobilization of central bank assets and also gave a new impetus to the debate on the possible confiscation/temporary use of the immobilized central bank assets. Whether freezing and subsequent confiscation or, alternatively, temporary use of the central bank assets authorized by the executive decision of another state, that is to say without any court proceedings, contradicts the law of state immunity, has been a matter of heated academic debate. At least three divergent opinions on the matter exist. The first approach emphasizes the principle of sovereign equality of states as the foundation of the state immunity guarantees and argues for a very broad definition of immunity from execution, that covers all types of constraints.<sup>434</sup> The second approach that relies upon the United Nations Convention on Jurisdictional Immunities of States and Their Property (UN Convention) and the International Court of Justice's findings in *Jurisdictional Immunities of the State (Germany v Italy)*<sup>435</sup> on the procedural nature of state immunities asserts that an executive or legislative action that is not linked to any judicial proceeding might enable a state to "freeze, seize, and repurpose frozen assets".<sup>436</sup> An additional argument in this regard is that in its judgment in the *Central Bank of Iran v Council of the EU*,<sup>437</sup> the EU Court annulled the Council Regulation imposing EU sanctions (restrictive measures) on the Central Bank of Iran because the bank's activities in circumventing sanctions were not proven, and the principle of sovereign immunity was not even discussed by the Court.<sup>438</sup> The third approach contends that any proposal to confiscate central bank assets would almost inevitably require some form of judicial oversight, and the courts would be obligated to consider

---

<sup>434</sup> Jean-Marc Thouvenin and Victor Grandaubert argue that predicated on the principle of sovereign equality of states, immunity from constraint should be defined very broadly: it "covers not only pre- and post-judgment proceedings, but also all kinds of public constraint the forum State could exercise over the foreign State's property, including those which are independent of any judicial proceedings, to the extent that it infringes the foreign State's sovereignty." In substance, their argument sounds: "non-judicial measures can hinder the foreign State's management of its property and should in principle be covered by immunity from execution under customary international law." Thouvenin and Grandaubert (2019), (n 38) pp. 247 – 250.

<sup>435</sup> Judgment of the International Court of Justice, Case 2012/2, *Jurisdictional Immunities of the State (Germany v. Italy: Greece intervening)*, 3 February 2012.

<sup>436</sup> Webb P. (2022), "Ukraine Symposium – Building Momentum: Next Steps Towards Justice for Ukraine", *Lieber Institute*, <https://lieber.westpoint.edu/building-momentum-next-steps-justice-ukraine/>; Moiseienko A., International Lawyers Project and Spotlight on Corruption (2022), *Frozen Russian Assets and the Reconstruction of Ukraine: Legal Options, Research Paper*.

<sup>437</sup> Judgment of 18 September 2014, *Central Bank of Iran v Council of the European Union*, Case T-262/12, ECLI:EU:T:2014:777.

<sup>438</sup> Ronzitti N. (2016), "Sanctions as Instruments of Coercive Diplomacy: An International Law Perspective", in *Coercive diplomacy, sanctions and international law*, Ronzitti N. (eds), Brill | Nijhoff.



the issue of state immunity and the immunity entitlements granted to the 'property of the central bank or other monetary authority of the state'.<sup>439</sup>

### 3.2 State immunity and central bank assets: is there a room for a new exception?

While achieving a peace agreement with the Russian Federation does not reside in the realm of near or mid-term possibility, the discussions on finding legal ways to use frozen and immobilized Russian assets to rebuild Ukraine without Russia's consent have flourished. In the previous section, I have explained how it remains contested if any use of immobilized central bank assets could potentially violate state immunity. Against this backdrop, the discussions revolve around the possibility of formulating a narrow exception to the state immunity entitlements.

The rules on state immunity, codified in the UN Convention and accepted as a reflection of the current state of customary international law, stipulate three exceptions to immunity from execution.<sup>440</sup> These exceptions are: express consent,<sup>441</sup> allocation/earmarking of property,<sup>442</sup> and post-judgment measures that might be taken against the property of the state "in use or intended for use by the State for other than government non-commercial purposes".<sup>443</sup>

Discussing the possibility of a narrow exception to immunity entitlements, two ideas gained some support. The first idea is an exception that is affirmed by a resolution of the UN General Assembly (majority vote). The second is an exception that abrogates state immunity based on a multilateral treaty agreed by a coalition of states that include "(i) Ukraine, (ii) states that have frozen Russian assets, and (iii) states whose security is tangibly and adversely impacted by Russia's war in Ukraine, such as EU Member States".<sup>444</sup>

Regarding the first option, Professor Philippa Webb – writing about the practical steps of bringing justice to Ukraine – quoted Amal Clooney's speech, in which she stated that "[t]he UN General Assembly should make clear that sovereign immunity should not prevent Russian state assets being made available to Ukraine and its people – and that the assets of all those who support the war are at risk".<sup>445</sup> Yet, it remains doubtful if such a UN General Assembly resolution could be endorsed by the majority of the UN Members. Turning to the second option, the media reports that at the recent meeting of G7 Justice and Finance ministers, the European Commission pushed for a G7 statement on leveraging Russian assets for Ukraine's reconstruction, but its

---

<sup>439</sup> Ingrid (Wuerth) Brunk argues that confiscation of the central bank assets "would almost certainly violate foreign sovereign immunity" and that such a move would most probably not be justified as third-party countermeasures. Brunk (Wuerth) I. (2023a), "Countermeasures and the Confiscation of Russian Central Bank Assets", *Lawfare*, <https://www.lawfaremedia.org/article/countermeasures-and-the-confiscation-of-russian-central-bank-assets>.

<sup>440</sup> Fox and Webb (2015) (n 40).

<sup>441</sup> UN Convention on State Immunity, Articles 18(a) and 19(a) (n 41).

<sup>442</sup> *ibid.* (n 41), Articles 18(b) and 19(b).

<sup>443</sup> *ibid.* (n 41), Article 19(c).

<sup>444</sup> Moiseienko, International Lawyers Project and Spotlight on Corruption (2022) (n 44).

<sup>445</sup> Webb (2022) (n 44).

efforts came to no fruition.<sup>446</sup> In light of these developments, it is highly unlikely that any of the options establishing a new exception to immunity guarantees can materialize any time soon.

### 3.3 Denying state immunity as permissible countermeasures?

State actions need a justification as countermeasures only if they violate an international obligation of a state taking them. This might be the case if it is argued that actions such as confiscation of the central bank assets or their temporary use are incompatible with the customary international law of state immunity. For the subsequent analysis, it is presumed that confiscation or temporary use of central bank assets might encroach upon the state immunity guarantees.

To be justified as a countermeasure, a measure – in this case, denial of state immunity guarantees – should comply with a number of substantive and procedural preconditions codified in the Draft Articles on Responsibility of States for Internationally Wrongful Acts (Draft Articles). The substantive prerequisites are enumerated in Articles 49–51 of the Draft Articles,<sup>447</sup> while the procedural ones are listed in Article 52.<sup>448</sup>

In the ongoing legal discussions, the possibility to take countermeasures against the Russian Federation is grounded in one of two reasons: either its aggression against Ukraine, which is also characterized by the egregious violations of international humanitarian and human rights law, or its obligation to pay reparations for the damage caused, which it has not fulfilled yet.<sup>449</sup> Regarding the latter aspect, under international law, Ukraine is entitled to reparations for the damage caused by the Russian Federation.<sup>450</sup> This right was confirmed by the UN General Assembly. On 14 November 2022, the UN General Assembly adopted a resolution in which it recognized that the Russian Federation must be held to account for any violations of international law in or against Ukraine, including any damage caused by such acts, and should make “reparation for the injury, including any damage, caused by such acts”.<sup>451</sup>

---

<sup>446</sup> Tamma (2023) (n 30).

<sup>447</sup> Among the most important preconditions are: countermeasures can be taken only against a state which is responsible for an internationally wrongful act (Article 49), there is a defined group of international obligations that cannot be affected by countermeasures (Article 50), and countermeasures must be proportional (Article 51).

<sup>448</sup> Procedural preconditions include: a duty to call upon the responsible state to fulfil its obligations, a duty to notify the responsible state of a decision to take countermeasures, a duty to suspend countermeasures either if the wrongful act has ceased or if there is a pending dispute before the tribunal.

<sup>449</sup> Ingrid Brunk discusses both grounds for countermeasures. Brunk (Wuerth) I. (2023b), “Central Bank Immunity, Sanctions, and Sovereign Wealth Funds”, *Vanderbilt Working Paper 23-12* (forthcoming *George Washington Law Review* 2023); Anton Moiseienko in his analysis focused on Russia’s violation of the erga omnes obligations, i.e., the prohibition of aggressive war. Moiseienko A. (2023), “The Freezing and Confiscation of Foreign Central Bank Assets: How Far Can Sanctions Go?”, (updated September 25, 2023) SSRN, <https://ssrn.com/abstract=4420459>; Hathaway, O. A., Mills, M. and Poston, T. (2023), “War Reparations: The Case for Countermeasures”, *Stanford Law Review*, Vol. 76, No. 5, (Forthcoming), SSRN, <https://ssrn.com/abstract=4548945>.

<sup>450</sup> “The responsible State is under an obligation to make full reparation for the injury caused by the internationally wrongful act.” Article 31(1), ILC, Draft Articles on Responsibility of States for Internationally Wrongful Acts (2001), UN Doc. A/56/10 (ARSIWA).

<sup>451</sup> United Nations General Assembly (2022), *Furtherance of remedy and reparation for aggression against Ukraine: Resolution adopted by the General Assembly on 14 November 2022*, UN doc. A/RES/ES-11/5.

Furthermore, this resolution recommends the creation of an international register of damage that was established by the Council of Europe in May 2023.<sup>452</sup>

There are three characteristics of permissible countermeasures, which states might find hard to fulfil if they decide to confiscate immobilized Russian Central Bank assets or put them into a temporary management scheme. The first and the least problematic characteristic is the objective of countermeasures, which reads as “to induce that State [a State which is responsible for an internationally wrongful act] to comply with its obligations”,<sup>453</sup> from which it flows logically that countermeasures should not be punitive.<sup>454</sup> It is feasible to frame confiscation or temporary use of immobilized assets as a measure aimed at inducing compliance either with the obligation to cease an act of aggression or with the obligation to pay reparations. For example, Lawrence Summers, Philip Zelikow and Robert Zoellick in their recent contribution to the *Economist* proposed to “transfer frozen Russian assets into escrow” and this, according to them, “would induce Russia to perform its legal duty to compensate”.<sup>455</sup>

The second prerequisite of permissible countermeasures is that they should be taken by a state or states entitled to do so. Specifically, the Draft Articles distinguish between injured and non-injured states, and the entitlement to impose countermeasures is explicitly granted only to injured states,<sup>456</sup> thus leaving the question of the legality of third-party countermeasures (countermeasures taken by non-injured states) undecided.<sup>457</sup> Arguably, states that have immobilized Russian Central Bank assets belong to the category of non-injured states, and thus their right to take countermeasures is questionable.

The third attribute is the temporary and reversible nature of countermeasures. The text of Article 49(2)-(3) of the Draft Articles provides legal ground to argue that countermeasures should be reversible, although it is well-acknowledged that the duty to take reversible countermeasures is not absolute.<sup>458</sup> Article 53 of the Draft Articles requires that: “[c]ountermeasures shall be terminated as soon as the responsible State has complied with its obligations”. It is debatable if a temporary denial of state immunity

---

<sup>452</sup> Council of Europe (2023), *Resolution CM/Res(2023)3 establishing the Enlarged Partial Agreement on the Register of Damage Caused by the Aggression of the Russian Federation against Ukraine*, [https://search.coe.int/cm/Pages/result\\_details.aspx?ObjectID=0900001680ab2595](https://search.coe.int/cm/Pages/result_details.aspx?ObjectID=0900001680ab2595)

<sup>453</sup> ARSIWA (n 58), Article 49(1).

<sup>454</sup> The commentary to ARSIWA explains the non-punitive nature of countermeasures based on Article 49 and the requirement of proportionality enshrined in Article 51: “In some respects proportionality is linked to the requirement of purpose specified in article 49: a clearly disproportionate measure may well be judged not to have been necessary to induce the responsible State to comply with its obligations but to have had a punitive aim and to fall outside the purpose of countermeasures enunciated in article 49.”

<sup>455</sup> Summers L., Zelikow P., and Zoellick R. (2023), “Lawrence Summers, Philip Zelikow and Robert Zoellick on why Russian reserves should be used to help Ukraine”, *The Economist*, <https://www.economist.com/by-invitation/2023/07/27/lawrence-summe...t-zoellick-on-why-russian-reserves-should-be-used-to-help-ukraine>.

<sup>456</sup> Article 42 of ARSIWA lays out the definition of an injured state for the purposes of invoking state responsibility of another state. This definition is narrow and excludes states that are not directly affected by the violation. Article 48 stipulates the rules for an invocation of responsibility by a state other than an injured state. According to this article, non-injured states are not allowed to resort to countermeasures.

<sup>457</sup> Bogdanova I. (2022), *Unilateral Sanctions in International Law and the Enforcement of Human Rights*, Brill | Nijhoff, pp. 63-66.

<sup>458</sup> Commentary to the ARSIWA points out: “[...] the duty to choose measures that are reversible is not absolute.”, ILC, Commentary to ARSIWA, p. 131. Legal scholars in general support this view. Ruys T. (2017), “Sanctions, Retorsions and Countermeasures: Concepts and International Legal Framework” in *Research Handbook on UN Sanctions and International Law*, Van den Herik L. (ed), Edward Elgar Publishing, pp.19-51.

guarantees that results in a permanent confiscation of the immobilized assets or in a permanent confiscation of the proceeds generated by the immobilized central bank assets can be considered as temporary countermeasures. Those international legal scholars who oppose any actions with the immobilized Russian Central Bank assets particularly emphasize the requirements of temporality and reversibility as an insurmountable obstacle to attempts to justify such measures as permissible countermeasures.<sup>459</sup> Other legal commentators contend that confiscation of the Russian Central Bank assets meets the prerequisites for being permissible countermeasures, the view which is further supported by Russia's undeniable obligation to pay reparations.<sup>460</sup> The supporters of this view argue that it does not contradict the temporary nature of countermeasures: "[...] confiscating Russian state-owned assets as a countermeasure is consonant with the logic of ensuring that the state in breach of its obligations (Russia) does not continue to experience the negative impact of countermeasures once it ceases non-compliance."<sup>461</sup>

Legal uncertainties continue to haunt the debate on the possibility of justifying any actions with the immobilized Russian Central Bank assets, which adds an additional level of complexity to the issue of financing Ukraine's reconstruction.

## 4 Concluding remarks

Beyond the obvious question of Russia's accountability for its full-scale war, marked by the horrendous war crimes and the large-scale destruction, there is not much clarity regarding the financing of Ukraine's post-war reconstruction. This leads to a paradoxical situation: while the Russian Federation demonstrates complete disrespect for international law, even peremptory rules of international law, its state property might be shielded from confiscation by the very same rules. But as the war wears on and the legal discussions continue, there is a hope to develop a tenable legal position on finding ways to finance Ukraine's reconstruction.

---

<sup>459</sup> Brunk (2023b) (n 57).

<sup>460</sup> Moiseienko, International Lawyers Project and Spotlight on Corruption (2022) (n 44).

<sup>461</sup> *ibid.* (n 44), p. 30.



## Part V

# Monetary Sovereignty: meaning and implications

# Monetary sovereignty: the euro and strategic internationalization

Jens van 't Klooster\*

## 1 Introduction

A widely used international currency is a major asset for any global actor and an important safeguard for effective monetary sovereignty. However, building and maintaining an international currency is a difficult undertaking that is inextricably linked to broader issues of domestic and foreign economic policy. It requires a central bank that is willing to support such efforts and a smart strategy for how to internationalize the currency. The absence of a such a strategy for the euro has weakened its status as a global currency.<sup>462</sup>

The project of monetary integration was reinitiated in 1987 to “reduce dependency on the dollar” and improve the Member States’ “scope for monetary policy action”.<sup>463</sup> Around that time, the Italian central banker Tommaso Padoa-Schioppa set out the case for a single currency as a project to strengthen the effective monetary sovereignty of the European Economic Community (EEC) and its Member States. By giving up national currencies, the Member States could create a powerful counter-balance against the dollar, inaugurating “a more stable multi-polar monetary regime”.<sup>464</sup>

Despite the high ambitions at its inception, the euro’s international use remains comparable to the Western European currencies that it replaced. Consider euro-denominated Forex (FX) reserve assets held by central banks. Before the introduction of the euro in 1999, around 60 % of global FX reserves were dollar-denominated with just over 20 % of reserve assets held in D-marks, French francs, Dutch guilders and the European currency unit (ECU).<sup>465</sup> In 2022, 20.5 % of reserve assets were euro-

---

\* Assistant Professor for Political Economy at the University of Amsterdam, the Netherlands. I would like to thank the organisers for the conference and thank the other panellists, Corinne Zellweger-Gutknecht and Rhoda Weeks-Brown, the chair, Luis de Guindos, as well as Regine Eheleiter, Steffen Murau, Sara Murawski and Sander Tudoir for helpful comments.

<sup>462</sup> On the obstacles to euro internationalization, see inter alia Emerson, M., Gros, D., Italianer, A., Pisani-Ferry, J., and Reichenbach, H. (1992), *One Market, One Money: An Evaluation of the Potential Benefits and Costs of Forming an Economic and Monetary Union*, Oxford University Press, Oxford; Hartmann, P. and Issing, O. (2002), ‘The International Role of the Euro’, *Journal of Policy Modeling*, Vol. 24, No 4, pp. 315–45; Germain, R. and Schwartz, H. (2014), ‘The Political Economy of Failure: The Euro as an International Currency’, *Review of International Political Economy*, Vol. 21, No 5; pp. 1095–1122; Helleiner, E. (2015), ‘The Future of the Euro in a Global Monetary Context’, in Matthijs, M. and Blyth, B. (eds.), *The Future of the Euro*, Oxford University Press, Oxford; Vermeiren, M. (2019), ‘Meeting the world’s demand for safe assets? Macroeconomic policy and the international status of the euro after the crisis’, *European Journal of International Relations*, Vol. 25, No 1, 30–60. Ilzetzki, E., Reinhart, C., and Rogoff, K. (2020), ‘Why is the euro punching below its weight?’, *National Bureau of Economic Research*, Cambridge MA.

<sup>463</sup> Genscher, H.D. (1988), “Memorandum für die Schaffung eines europäischen Währungsraumes und einer Europäischen Zentralbank”, *Bundesbank Archive*, B330/018912

<sup>464</sup> Emerson et al., *One Market, One Money* (n 1), p. 178.

<sup>465</sup> Ilzetzki, Reinhart, and Rogoff, ‘Why Is the Euro Punching below Its Weight?’ (n 1), p. 416.

denominated.<sup>466</sup> Private sector FX transactions also indicate continuity. In 2022, around 90 % of all FX transactions had the dollar on one side, with the euro in 38 % of transactions.<sup>467</sup> Before the introduction of the euro, around 35 % of FX transactions involved the D-mark alone.<sup>468</sup>

**Table A**  
Euro area inflation and US dollar/Euro exchange rate

	Components	May 21	Dec 21	Jul 22	Oct 22	Dec 22
Annual HICP (%)	All items	2.0	5.0	8.9	10.6	9.2
	Food, alcohol & tobacco	0.6	3.2	9.8	13.1	13.8
	Energy	13.1	25.9	39.6	41.5	25.7
	Non-energy industrial goods	0.7	2.9	4.5	6.1	6.4
	Services	0.1	2.4	3.7	4.3	4.4
US\$/EUR exchange rate		1.22	1.13	1.0	1.0	1.07

Notes: Eurostat, ECB

The constrained monetary sovereignty of the European Union (EU) was an exacerbating factor in the global inflationary crisis of 2022 (Table A). After the Russian invasion of Ukraine, energy prices sky-rocketed, shooting up to record levels by the second half of the year. In October 2022 inflation had reached 10.7 %, with energy prices rising 41.5 %. By that time, the euro had also depreciated against the dollar by over 20 %. With an estimated 85 % of the EU's energy imports denominated in dollars, the strong dollar directly exacerbated the euro area's inflationary plight.<sup>469</sup> In 2022, history came to haunt the EU. It did not just pay the price for an energy policy premised on imported fossil fuels, but also for its failure to internationalize the euro.

So, what has stopped the European Central Bank (ECB) from promoting a more prominent international role for the euro? To answer that question, this chapter studies how European central bankers have thought about monetary sovereignty and the international role of the euro from the 1980s onwards. The EU was designed without any particular strategy for promoting its international use. Although the ECB's mandate requires supporting the general economic policies in and of the EU, any effective measure to promote euro internationalization will favor some economic policy objectives over others. The ECB's early interpretation of its mandate, in particular the narrow focus that dominated its 1998 and 2003 monetary policy strategies, effectively stopped the central bank from promoting euro internationalization. Since then, a process of institution building and policy learning has allowed the central bank to move beyond its earlier policy of neutrality vis-à-vis EU economic policy. The rediscovery of

<sup>466</sup> European Central Bank (2023), *The International Role of the Euro*, Frankfurt am Main, June.

<sup>467</sup> ECB. All foreign exchange transactions involve two currency so the total number sums to 200 %, but any given currency can appear at most in 100 % of FX transactions.

<sup>468</sup> Ilzetzki, Reinhart, and Rogoff, 'Why Is the Euro Punching below Its Weight?' (n 1), p. 416. This number overstates the importance of pre-EMU currencies because many intra-EU trades were denominated in D-mark. However, considering only the D-mark provides a low estimate of the importance of pre-EMU currencies.

<sup>469</sup> European Commission (2023), "The Euro in the Field of Energy", [https://energy.ec.europa.eu/topics/markets-and-consumers/euro-field-energy\\_en](https://energy.ec.europa.eu/topics/markets-and-consumers/euro-field-energy_en).



the ECB's secondary mandate in the context of its 2021 monetary policy opens up the scope for a more explicit strategy of internationalization. Creating an EU-level strategy sets priorities in the face of not only the many economic and financial implications, but also the environmental and geopolitical ones of a truly international euro.<sup>470</sup> The EU should explore the potential of the euro as the international currency for clean energy.

This chapter is structured as follows. Section 2 covers the historical ambitions for restoring the effective monetary sovereignty of EEC's Member States through a Western European currency as a counter-weight to the dollar. In section 3, I turn to the ECB's monetary policy strategies of the early 2000s to explain the ECB's attitude of neutrality towards euro internationalization. In this context, I single out the ECB's unwillingness to guarantee the safe asset status of euro-denominated sovereign debt as a key obstacle to a larger international role for the euro. I conclude by considering the open strategic questions that the EU faces today. I then set out how the ECB's secondary mandate could inform the development of an EU strategy for euro internationalization (section 4).

---

<sup>470</sup> de Boer, N., and van 't Klooster, J. (2020), 'The ECB, the courts and the issue of democratic legitimacy after Weiss', *Common Market Law Review*, Vol. 57, No 6, pp. 1689–1724; Van 't Klooster, J., and de Boer, N. (2022), 'What to Do with the ECB's Secondary Mandate', *JCMS: Journal of Common Market Studies*, <https://doi.org/10.1111/jcms.13406>; Ioannidis, M., Hlásková, S. J., and Zilioli, C. (2021), 'The Mandate of the ECB: Legal Considerations in the ECB's Monetary Policy Strategy Review', Occasional Paper Series, 276, European Central Bank; Ioannidis, M., and Zilioli, C. (2022), 'Climate change and the mandate of the ECB: Potential and limits of monetary contribution to European green policies', *Common Market Law Review*, Vol. 59, No 2; Smoleńska, A. (2023), 'A European Credit Council for Consistent and Informed Policymaking', *Accounting, Economics, and Law: A Convivium*, <https://doi.org/10.1515/acl-2022-0065>.

## 2 A currency for monetary sovereignty

How we evaluate the euro and its international role is shaped by our implicit conceptions of sovereignty. To this day, loss of sovereignty remains a widespread objection to euro membership.<sup>471</sup> However, historically the currency was conceived of as a project for regaining effective monetary sovereignty in a world of financial globalization.<sup>472</sup>

The idea that European integration is a threat to national sovereignty was already widespread at the time that the Economic and Monetary Union (EMU) was designed. For example, Karl Otto Pöhl argued at the time that “the loss of national sovereignty in economic and monetary policy associated with it is so serious that it would probably be bearable in the context of extremely close and irrevocable political integration”.<sup>473</sup> The EU, Pöhl assumed, would need to be almost as close-knit as its Member States for a single currency to become conceivable.

According to the Westphalian use of the term, monetary sovereignty consists in the ability of a state to issue a currency and regulate its use. In the context of international law, a legal principle of monetary sovereignty requires that states refrain from interfering in the domestic monetary affairs of other states.<sup>474</sup> Reflecting that legal background, the Westphalian conception of sovereignty is a “negative” conception of sovereignty. It focuses on what states can do without interference from other states, rather than considering what they can achieve.<sup>475</sup> Giving up monetary sovereignty – it is then quickly inferred – means no longer deciding on the most important choices concerning the issuance and regulation of money.

The Westphalian conception is invoked in claims to the effect that joining a currency union involves giving up monetary sovereignty. Charles Proctor, for example, writes that “[t]he transfer or limitation of national monetary sovereignty was [...] taken to its furthest extreme on 1 January 1999, when the euro was created.[...] [A]ll national powers of legislation and action in the monetary law field came to an end when the euro was introduced in the participating Member States”.<sup>476</sup>

The Italian central banker Tommaso Padoa-Schioppa, then working at the Directorate-General for Economic Affairs (DG II), was a prominent policymaker involved in creating

---

<sup>471</sup> Smoleńska, A. and Tokarski, P. (2023), “The elephant in the room in Poland’s election? Joining the euro”, *LSE EUROPP – European Politics and Policy*, London, September.

<sup>472</sup> See in particular Jabko, J. (1999), ‘In the Name of the Market: How the European Commission Paved the Way for Monetary Union’, *Journal of European Public Policy*, Vol. 6, No 3, pp. 475–95.

<sup>473</sup> Pöhl, K.O. (1989), “The further development of the European Monetary System”, Annex to the Delors Report, EC Publications Office, Luxembourg, pp. 131-55.

<sup>474</sup> Proctor, C. (2012), *Mann on the Legal Aspect of Money*, 7th ed, Oxford University Press, Oxford, para. 19.02-8; Zimmermann, D.C. (2013), *A Contemporary Concept of Monetary Sovereignty*, Oxford University Press, Oxford.

<sup>475</sup> Jackson, R. H. (1992), *Quasi-States: Sovereignty, International Relations and the Third World*, Cambridge University Press, Cambridge; Ronzoni, M. (2012), Two conceptions of state sovereignty and their implications for global institutional design, *Critical Review of International Social and Political Philosophy*, Vol. 15, No 5, pp. 573–591.

<sup>476</sup> Proctor, Mann on the Legal Aspect of Money (n 13), para. 31.09-31.10.

the euro. He set out an alternative vision of sovereignty within monetary integration.<sup>477</sup> As Padoa-Schioppa noted as chair of a group of experts that published a commission report on monetary integration, in the 1970s monetarists had waged “a powerful intellectual campaign [...] in support of floating rates, based on the argument that they would restore full independence of national economic policies”.<sup>478</sup> However, “[a]s the years passed, it became increasingly clear that the elimination of the exchange rate constraint only restored limited autonomy to macroeconomic policies, while unrestricted floating of exchange rates risked undermining the freedom of trade and capital movements.”<sup>479</sup> In practice, the Netherlands and Belgium closely followed the monetary policy of the Deutsche Bundesbank.<sup>480</sup> The French and Italians could diverge temporarily but found it hard to do so over longer periods. The Bundesbank itself remained tightly constrained by the interest rate policy of the US.

Against that background, Padoa-Schioppa argued that to focus on loss of sovereignty was a one-sided way to understand the EMU. Monetary integration offered Member States a range of benefits such as improved external and internal monetary stability, and collective decision-making, while the currency would create a powerful counter-balance against the dollar. Relying on a version of the macroeconomic trilemma, he argued that that giving up the tight exchange rate discipline of the European Monetary System (EMS) would give the EU, and by extension its Member States, more scope for domestic macroeconomic policy.

Padoa-Schioppa’s argument reflects the fact that due to financial globalization, a currency union can increase what Steffen Murau and I have described as effective monetary sovereignty.<sup>481</sup> Effective monetary sovereignty concerns the ability of states to achieve their objectives by governing money. This effective conception of monetary sovereignty is distinct from the Westphalian conception in two ways.<sup>482</sup> First, rather than focusing on the ability of states to issue and regulate their national currency, our theoretical framework puts private credit money at the centre of analysis (Chart A). States remain crucial, but first and foremost for creating and governing the unit of account, i.e. the dollar, the euro, etc. At the same time, a wide variety of public and private actors issue claims denominated in that unit of account that take on money-like characteristics. Already within national jurisdictions, the segment of the monetary system that states directly control is limited. We also emphasize the complex global structure of the monetary system, which often situates legal authority over money

---

<sup>477</sup> Padoa-Schioppa, T. (1987), *Efficiency, Stability, and Equity: A Strategy for the Evolution of the Economic System of the European Community*, Oxford University Press, Oxford. Padoa-Schioppa, T. (1988), ‘The European Monetary System: A long-term view’, in F. Giavazzi, M. Miller, and S. Micossi (eds.), *The European Monetary System*, Cambridge University Press, Cambridge, pp. 369–384; Padoa-Schioppa, T. (2001), *The Road to Monetary Union in Europe: The Emperor, the Kings, and the Genies*, Oxford University Press, Oxford. For a similar reading, see Jabko, ‘In the Name of the Market’ (n 11).

<sup>478</sup> Tommaso Padoa-Schioppa, ‘Introduction to “Il sistema dei cambi, oggi”’ Historical Archives of the European Union (TPS-325), p. 3.

<sup>479</sup> *ibid.*, p. 4.

<sup>480</sup> Padoa-Schioppa, *Efficiency, Stability, and Equity* (n 16), p. 74.

<sup>481</sup> Murau, M. and van 't Klooster, J. (2022), ‘Rethinking Monetary Sovereignty. The Global Credit Money System and the State’, *Perspectives on Politics*, <https://doi.org/10.31235/osf.io/k9qm8>. See also the contribution by Corinne Zellweger-Gutknecht to this volume.

<sup>482</sup> Conceptually, effective monetary sovereignty is closely aligned with the idea of open strategic autonomy, see European Central Bank (2023), *The EU’s Open Strategic Autonomy from a Central Banking Perspective: Challenges to the Monetary Policy Landscape from a Changing Geopolitical Environment*, July.

outside the jurisdiction that issues the unit account. Offshore money is not created onshore and then moved abroad, but rather created 'from nothing' on foreign public and private balance sheets.

#### Chart A

#### Effective monetary sovereignty and the three dimensions of monetary governance

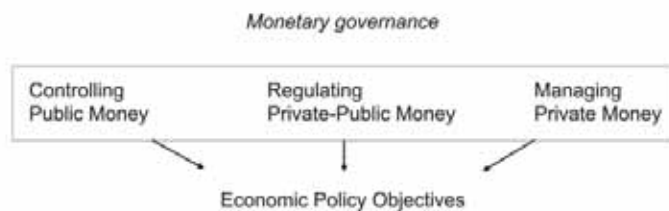

Notes: [Murai](#) and van [Klooster](#), 'Rethinking Monetary Sovereignty: The Global Credit Money System and the State', p.3.

A second way in which effective monetary sovereignty is distinct concerns the meaning of sovereignty. Where the Westphalian conception focuses on what states can do without interference, effective conceptions concern what states can actually achieve. ECB President Mario Draghi sometimes argued for an effective conception of sovereignty, for example pointing out that "[t]rue sovereignty is reflected not in the power of making laws - as a legal definition would have it - but in the ability to control outcomes and respond to the fundamental needs of the people: what John Locke defines as their 'peace, safety, and public good'. The ability to make independent decisions does not guarantee countries such control. In other words, independence does not guarantee sovereignty".<sup>483</sup>

In contrast to the Westphalian conception, effective sovereignty reflects the actual policy space available to states. The emphasis is on governing money effectively, not just nationally. Coordinating regulations internationally may enhance sovereignty by harnessing interdependence.

By giving the EU and its Member States a powerful global role, the euro was meant to contribute to a more effective common economic policy. Despite those ambitions, we find little in the way of a plan for promoting the international role of the euro in the debate around the creation of EMU and the drafting of the 1992 Maastricht Treaty.<sup>484</sup> Rather than pursuing any particular strategy, the sheer size of the new currency would be more or less sufficient to rival the dollar.<sup>485</sup> It was left to the ECB to develop its own stance on euro internationalization.

<sup>483</sup> Draghi, M. (2019), "Sovereignty in a globalised world", Speech on the award of Laurea honoris causa in law from Università degli Studi di Bologna on 22 February 2019 in Bologna, <https://www.ecb.europa.eu/press/key/date/2019/html/ecb.sp190222-fc5501c1b1.en.html>.

<sup>484</sup> Delors, J., Andriessen, F., Boyer, M., and Chalikias, D., et al (1989), Report on economic and monetary union in the European Community [Committee for the Study of Economic and Monetary Union], Commission of the European Communities., paras 35–38; Emerson et al., *One Market, One Money* (n 1), ch. 7; van den Berg, C. C. A. (2004), *The Making of the Statute of the European System of Central Banks*, Dutch University Press, Amsterdam, pp. 293–300.

<sup>485</sup> Emerson et al., *One Market, One Money* (n 1), pp. 178–89.

### 3 A currency without a state

In January 1999, Wim Duisenberg gave a speech to the American European Community Association at De Nederlandsche Bank, where the first President of the ECB announced that “[t]he euro has arrived. The Governing Council of the ECB has taken up the reins of monetary sovereignty in the euro area and a truly single monetary policy has been in place for two weeks”.<sup>486</sup>

However, the ambitions that Duisenberg set out for were modest. Rather than presenting the new currency as an instrument to support economic policies, the central bank would adopt an attitude of neutrality. It would contribute to the EU’s objectives only by pursuing the narrow monetary objective that the early ECB’s Governing Council had set itself.

I first discuss the ECB’s early reluctance to support an international euro.<sup>487</sup> I then explain how the ECB’s attitude of neutrality towards the safe asset status of euro area sovereign debt would undermine euro internationalization.

#### 3.1 Euro internationalization: the first years

Since the 1930s onwards, the United States (US) Treasury and the Federal Reserve System have pursued an active policy towards the promotion of international use of the dollar as the currency of the global economy. After the Second World War, the US efforts resulted in the Bretton Woods Agreement and its system of fixed exchange rates. From the late 1950s onwards, the US also (and somewhat unhelpful for that system) accepted the existence of ‘offshore’ dollar creation by private banks domiciled outside the US.<sup>488</sup> As the 1970s progressed, an active policy of dollar internationalization would not only result in a largely dollar-denominated global financial system. It would also make the dollar the currency of global fossil fuels, giving it its current role for of invoice currency for trade in fossil fuels.<sup>489</sup>

Despite the historical ambitions for a euro on a par with the dollar, Duisenberg was not too enthusiastic about its necessary implication: euro internationalization. As he wrote, “the Eurosystem will accept the international role of the euro as it develops as a result of market forces. To the extent that the Eurosystem is successful in meeting its mandate and maintaining price stability, it will also automatically foster the use of the euro as an international currency”.<sup>490</sup>

---

<sup>486</sup> Duisenberg, W. (1999), ‘The Euro Has Arrived’, Meeting of the American European Community Association on 14 January 1999 at De Nederlandsche Bank, [ecb.europa.eu/press/key/date/1999/html/sp990114.en.html](https://www.ecb.europa.eu/press/key/date/1999/html/sp990114.en.html).

<sup>487</sup> European Central Bank (1998), ‘A Stability-Oriented Monetary Policy Strategy for the ESCB’, [https://www.ecb.europa.eu/press/pr/date/1998/html/pr981013\\_1.en.html](https://www.ecb.europa.eu/press/pr/date/1998/html/pr981013_1.en.html); European Central Bank (2003), ‘The ECB’s Monetary Policy Strategy’, [https://www.ecb.europa.eu/press/pr/date/2003/html/pr030508\\_2.en.html](https://www.ecb.europa.eu/press/pr/date/2003/html/pr030508_2.en.html).

<sup>488</sup> Helleiner, E. (1994), *States and the Reemergence of Global Finance. From Bretton Woods to the 1990s*, Cornell University Press, Ithaca and London.

<sup>489</sup> Mitchell, T. (2011), *Carbon Democracy: Political Power in the Age of Oil*, Verso Books.; European Commission, ‘The Euro in the Field of Energy’ (n 8).

<sup>490</sup> Duisenberg, ‘The Euro Has Arrived’ (n 25).

Two key elements in the ECB's 1998 and 2003 monetary policy strategy explain the central bank's attitude of neutrality towards euro internationalization.

First, despite keeping an eye on the exchange rate, the only objective of monetary policy would be to keep consumer price growth below 2%.<sup>491</sup> The main contribution that the ECB sought to make to external stability was to focus on medium-term monetary stability to the exclusion of other domestic macroeconomic objectives. The early ECB regularly invoked a radical version of new Keynesian divine coincidence: pursuing low consumer prices on a 2 to 5-year time horizon would under all circumstances also be the best possible way to contribute to the EU's broader economic policy objectives.<sup>492</sup>

Second, this narrow focus on medium-term consumer prices meant that the ECB's policies would be set without considering the economic policies of other EU bodies.<sup>493</sup> This fitted the exceptionally high level of policy independence that the central bank adhered to in the early years. It precluded most forms of *ex-ante* coordination on the objectives of monetary policy. Indeed, as envisaged by some of the early ECB Board Members, there would not be genuine monetary sovereignty on the EU level either. Rather the euro was to be autonomous from politics, invoking Friedrich von Hayek, its first chief economist Otmar Issing referred to the euro approvingly as "a currency without a state".<sup>494</sup>

Duisenberg also saw clear disadvantages to offshore euro creation where "a significant proportion of the money stock is circulating outside the euro area".<sup>495</sup> Offshore euro-deposits would destabilize the exchange rate and make monetary aggregates harder to interpret. In light of the conflicting economic policy implications of euro internationalization, the ECB's early attitude would be one of neutrality, almost indifference. Relying on international finance and the evolution of the global trading system to determine euro internationalization absolved the ECB's Governing Council from making any difficult choices on who should use the euro for what purposes.

## 3.2 Euro area safe-assets

The 2010-2012 euro area crisis called into question the safe asset status of euro area sovereign debt. Since then, the euro has remained plagued by large intra-euro area spreads: differences in yields between the debt issued by the individual Member States. The ECB's attitude of neutrality toward the economic policy objectives of the EU and its Member States stopped it from safeguarding the international status of the euro.

---

<sup>491</sup> ECB, 'A Stability-Oriented Monetary Policy Strategy for the ESCB'.

<sup>492</sup> Blanchard, O., and Galí, J. (2007), Real Wage Rigidities and the New Keynesian Model. *Journal of Money, Credit and Banking*, No 39, pp. 35–65; European Central Bank (2002), 'Clarifying the ECB Support for General Economic Policies in the Community', *ECB Archives*, [https://www.ecb.europa.eu/ecb/access\\_to\\_documents/document/pa\\_document/shared/data/ecb.dr.par.2021\\_0007\\_clarifyingmonpol2002.en.pdf](https://www.ecb.europa.eu/ecb/access_to_documents/document/pa_document/shared/data/ecb.dr.par.2021_0007_clarifyingmonpol2002.en.pdf).

<sup>493</sup> van 't Klooster and de Boer, 'What to Do with the ECB's Secondary Mandate' (n 9).

<sup>494</sup> Issing, O. (2006), "The euro – a currency without a state", European Central Bank, Helsinki, 24 March.

<sup>495</sup> Duisenberg, 'The Euro Has Arrived' (n 25).

The global role of the euro was from the start profoundly tied up with one of the most difficult issues of monetary integration: the treatment of government debt.<sup>496</sup> Deep and liquid financial markets are an essential precondition for an international currency. US Treasury debt serves a key role within the global financial system as the 'safe asset' for investors, which is used not only as a store of value but also as a benchmark for pricing. For this reason, ample availability and a stable value for government debt is widely recognized to be a key precondition for currency internationalization. However, US Treasuries can serve such a pivotal role because today around USD 18 trillion of Federal debt securities circulates outside the Federal Reserve System.<sup>497</sup> Austrian, Belgian, Dutch, French, Finnish and German central government debt together come to EUR 5.4 trillion, of which around EUR 2.7 trillion takes the form of a security not held by the ECB.<sup>498</sup>

### Chart B

#### The origin of intra-euro area spreads

Yield on periphery government debt (light blue) diverged from core government debt (dark blue) for the first time after the announcement of a minimum credit rating requirement in May 2005. The core countries are Austria, Belgium, France, and the Netherlands, while Ireland, Italy, Portugal, and Spain serve as periphery countries. All yields calculated as a spreads relative to German government debt.

(percentage point, 10-year government bonds)

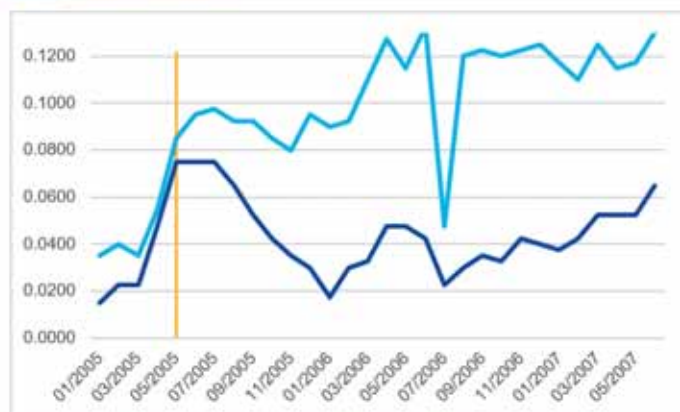

Source: Schuster, 'Sovereign Spreads, Central Bank Collateral Frameworks, and Periphery Press in the Eurozone'.

It is doubtful whether there can be currencies without a state, but there can certainly be no safe asset without a central bank. From its creation onwards, the Federal Reserve System has consistently backed US Treasury debt through direct purchases and open market operations.<sup>499</sup> In striking contrast, the early ECB took a much more

<sup>496</sup> Helleiner, 'The Future of the Euro in a Global Monetary Context'; Vermeiren, 'Meeting the World's Demand for Safe Assets?' (n 1).

<sup>497</sup> Fred Market Value of Marketable Treasury Debt (MVMTD027MNFBRBDAL); Federal Reserve Balance Sheet.

<sup>498</sup> Eurostat central government debt, ECB data.

<sup>499</sup> Bateman, W., and van 't Klooster, J. (2023), 'The dysfunctional taboo: Monetary financing at the Bank of England, the Federal Reserve, and the European Central Bank', *Review of International Political Economy*, <https://doi.org/10.1080/09692290.2023.2205656>; Bateman, W. (2023), 'The Fiscal Fed' (SSRN Scholarly Paper 4516824), <https://doi.org/10.2139/ssrn.4516824>.

hesitant approach.<sup>500</sup> This approach to government debt would profoundly shape the safe asset status of euro-denominated government debt.

The spreads between the Member States predate the 2010-2012 euro area crisis and have their roots in the ECB's broader attitude of neutrality. In the first years of the euro, intra-euro area spreads were almost non-existent, sometimes just a few basis points. A recent empirical study confirms that spreads emerged after May 2005 (Chart B).<sup>501</sup> That month, the ECB announced that it would make the eligibility of public debt as collateral for its monetary policy operations conditional on a sufficiently high credit rating issued by Fitch, S&P, and Moody's.<sup>502</sup> That decision is sometimes presented as a policy to punish governments for not adhering to the EU's Stability and Growth Pact.<sup>503</sup> My own archival work calls that indictment into question. Instead, the policy appears to have been introduced to signal the ECB's neutrality regarding the safe asset status of euro area government debt.<sup>504</sup> The ECB President Jean-Claude Trichet explained the decision to rely on credit rating agencies as final arbiter of sovereigns in 2005 by saying that "we mentioned also very clearly to market people that we were taking the paper at its market value, so that if the markets would assess that the paper was less credible and the spreads would augment, then the value of the paper that we would take as collateral would diminish".<sup>505</sup>

Already in 1997, when members of the European Monetary Institute's Monetary Policy Sub-Committee designed the ECB's early collateral framework, Deutsche Bundesbank officials had resisted relying on credit ratings for the evaluation of government debt. As they argued in a fax to the other members of the sub-committee, such a decision implied that "[r]ating agencies, not the ECB would decide on the eligibility of an individual issuer. This transfer of decision making to a very small number of private, profit oriented rating agencies (Moody's, S&P) will barely be covered by the idea and the rules of the EU-treaty. [...] The ECB would lose its sovereignty on the eligibility procedure, at least partly. Not even a minor level of discretionary decision making would remain with the ECB".<sup>506</sup>

Although all advanced economies faced market turbulence as a consequence of the 2007-2008 banking crisis, it did not typically escalate into a sovereign debt crisis. Where the Bank of England and the Federal Reserve System quickly launched large government debt purchase programs, the ECB's policy of neutrality hindered it from

---

<sup>500</sup> Van 't Klooster, J. (2023), The politics of the ECB's market-based approach to government debt. *Socio-Economic Review*, Vol. 21, No 2, pp. 1103–1123; Schuster, F. (2023), *Sovereign Spreads, Central Bank Collateral Frameworks, and Periphery Premia in the Eurozone*, Dezernat Zukunft, Berlin.

<sup>501</sup> Schuster, 'Sovereign Spreads, Central Bank Collateral Frameworks, and Periphery Premia in the Eurozone' (n 40).

<sup>502</sup> Trichet, J.-C. (2005b), Introductory statement to the press conference of 7 April 2005, <https://www.ecb.europa.eu/press/pressconf/2005/html/is050407.en.html>.

<sup>503</sup> Buiter, W. H., and Sibert, A. (2005), 'How the Eurosystem's Treatment of Collateral in its Open Market Operations Weakens Fiscal Discipline in the Eurozone (and what to do about it)', CEPR Discussion Papers 5387, CEPR, London; Orphanides, A. (2017), 'ECB Monetary Policy and Euro Area Governance: Collateral Eligibility Criteria for Sovereign Debt', Working Paper 5258–17, MIT Sloan School.

<sup>504</sup> Van 't Klooster, 'The Politics of the ECB's Market-Based Approach to Government Debt' (n 40).

<sup>505</sup> Trichet, J.-C. (2005a), Introductory statement to the press conference of 1 December 2005, <https://www.ecb.europa.eu/press/pressconf/2005/html/is051201.en.html>.

<sup>506</sup> Deutsche Bundesbank (2020), "Task Force Meeting April 9, 1997 - Selection of Tier 1 Eligible Assets", ECB Archives (LS/PT/2020/7).



doing the same.<sup>507</sup> A policy of neutrality with regard to government debt, relying on external credit ratings to exercise the ECB's sovereignty over the currency, left the ECB unequipped to safeguard the safe asset status of Member State debt. The sovereign debt crisis that followed profoundly damaged the euro's international role.

---

<sup>507</sup> Bateman and van 't Klooster, 'The Dysfunctional Taboo' (n 39).

## 4 A truly global currency?

The people listening to Duisenberg in January 1999 presumably had no idea how influential his remarks on the international euro would be. As late as 2018, ECB President Draghi repeated those words almost verbatim, saying that “[t]he international role of the euro is primarily determined by market forces. The Eurosystem neither hinders nor promotes the international use of the euro”.<sup>508</sup>

Since then, the ECB’s attitude towards internationalization has shifted, with the central bank’s earlier ambivalence displaced by a tentative endorsement of euro internationalization. However, as I now argue, the deeper issue that Duisenberg identified remains. Any policy to promote the EU’s effective monetary sovereignty also involves choices in which objectives to promote and how to go about doing this. Successful internationalization of the euro requires developing a strategy for navigating the broader issues of domestic and foreign economic policy of making an international currency. Inter-institutional coordination with regard to the ECB’s secondary mandate could play a crucial role in developing that strategy.<sup>509</sup>

### 4.1 Euro internationalization today

2019 is a key turning point in the history of the international euro. Citing a 2018 European Commission’s initiative, Draghi explained that the ECB would from then on “support” the EU’s efforts to strengthen the euro’s international role.<sup>510</sup> A few months earlier, Benoît Cœuré already set out the broader stakes the central bank’s new approach.<sup>511</sup> As he explained, and he was not the first to say it, the dollar would not necessarily retain its current outsized importance. Before the First World War, the global financial system revolved around the pound sterling, the Deutsche mark and the French franc. Despite the ambitions of the speech Cœuré also continued to invoke the old policy of neutrality, emphasizing that any policy of euro internationalization would have to be based on benefits to domestic price stability. “It is not for us to decide on Europe’s role in the world, or on which countries outside Europe choose to use the euro and which do not. We continue to see the global role of the euro as being primarily a market-led process”.<sup>512</sup>

Draghi’s foreword to the 2019 international role of the euro report revised the ECB’s 1999 analysis of advantages and disadvantages. Arguing that the balance of benefits and costs had evolved, the report called into question Duisenberg’s earlier objections. Monetary aggregates, as the report stated politely, had lost their significance due to “enhanced tools for the ECB’s monetary analysis”, while capital flow volatility “is not a

---

<sup>508</sup> European Central Bank (2018), *The International Role of the Euro*, p. 2.

<sup>509</sup> van 't Klooster and de Boer, 'What to Do with the ECB's Secondary Mandate' (n 9); Grünewald, S. and Van 't Klooster, J. (2023), 'New Strategy, New Accountability: The European Central Bank and the European Parliament after the Strategy Review', *Common Market Law Review*, Vol. 60, pp. 959-998.

<sup>510</sup> European Central Bank (2019), *The International Role of the Euro*, p. 2.

<sup>511</sup> Benoît Cœuré, 'The Euro's Global Role in a Changing World: A Monetary Policy Perspective', speech at the Council on Foreign Relations, New York City, 15 February 2019, <https://www.ecb.europa.eu/press/key/date/2019/html/ecb.sp190215~15c89d887b.en.html>.

<sup>512</sup> *ibid.*

feature specific to international currency issuers but a feature of any financially open economy”.

The report also made clear that the advantages of an international currency were vast. The demand for dollar-denominated debt from states, companies, and households in surplus provides the US Treasury, but also US companies, with almost unlimited liquidity. The US’s monetary policy also sets the pace for the global economy, thereby strengthening the effectiveness of monetary expansion and contraction for steering domestic economic development. The Covid-19 pandemic showed that the dollar not only gives the US ample economic and geopolitical power, but also protects it against the shocks of the pandemic. As Fabio Panetta explained in June 2020, “[t]he dollar’s predominant role in global trade has helped shield the US economy from the exchange-rate appreciation that safe-haven status usually brings. And American companies have enjoyed the stability that comes from being able to conduct international transactions in their own currency”.<sup>513</sup>

And then there are the benefits for foreign policy, such as the potential of geopolitical weaponization; an advantage that would become crucial in the 2022 response to the Ukraine invasion.<sup>514</sup> The list goes on and on.

Despite acknowledging the clear benefits of a more international currency, the 2019 rediscovery has to date not resulted in an answer to the considerations that led the early ECB to adopt a position of neutrality. When aggregated up, the case is clear that the euro internationalization is a net positive. However, the devil is, as always, in the details.

## 4.2 Promoting the EU’s economic policy objectives

As a more international currency comes with large benefits, but also more costs, the question of how to internationalize the currency becomes all but unavoidable. Pursuing a larger international role for the European currency requires making choices that involve prioritizing economic policy objectives.

For one, as we already saw, euro internationalization is closely intertwined with the market for euro-denominated safe assets. The benefits of a more prominent international role remain “unevenly skewed towards the few countries issuing what investors perceive to be safe assets.”<sup>515</sup> To promote the international role of the euro, the ECB would either need to support the safe asset status of other Member States or provide even more benefits to those fortunate enough to already enjoy that status. The ongoing wrangling around the ECB’s government debt purchases illustrates the deeply political nature of this dossier.

---

<sup>513</sup> Panetta, F. (2020), Sharing and strengthening the euro’s privilege, ECB Blog, June. <https://www.ecb.europa.eu/press/blog/date/2020/html/ecb.blog200612-312fc9d1dc.en.html>.

<sup>514</sup> Quaglia, L., and Verdun, A. (2023), Weaponisation of finance: The role of European central banks and financial sanctions against Russia, *West European Politics*, Vol. 46, No 5, pp. 872–895.

<sup>515</sup> Panetta, ‘Sharing and Strengthening the Euro’s Privilege’ (n 53).

A second challenge for a more international euro concerns the availability of liquidity support outside the euro area. The exorbitant privilege of a global currency also comes with what is typically described as an exorbitant duty. As foreign states, banks and firms become indebted in the currency, they will need emergency credits when market liquidity dries up. Its international role has placed the US, via the International Monetary Fund (IMF) and through the issuance of emergency swap lines, in a position of international lender of last resort. Although the ECB provides unlimited swap lines to some non-EU central banks, even within the EU liquidity support for offshore euros remains limited and decision-making remains shrouded in mystery (Table B).<sup>516</sup> The exorbitant duty, however, does not pertain solely to EU Member States, and any further international role for the euro unavoidably raises new choices in who should receive international credit lines, and under what condition.

**Table B**  
Euro liquidity support and percentage of domestic bank liabilities denominated in euros

Subtitle (delete if not needed)

(add further description)

Counterparty	Type of arrangement	Limited or unlimited	Expiry date	% Euro deposits
BoC, SMU, BoE, BoJ, Fed	Swap line	Unlimited	Standing	Low
<a href="#">Danmarks Nationalbank</a>	Swap line	Limit	Standing	4%
<a href="#">Sveitsas Riksbank</a>	Swap line	Limit	Standing	14%
<a href="#">Narodowy Bank (Polski)</a>	Swap line	Limit	Jan 2024	8%
<a href="#">Magyar Nemzeti Bank</a>	Repo line	4,000	Jan 2024	18%
<a href="#">Banca Nazionale e Renditeci</a>	Repo line	4,500	Jan 2024	30%

Notes: ECB, NCB websites

A third issue is the design of a digital euro.<sup>517</sup> Protecting the international euro use of the euro remains a key driver behind the ECB's efforts to issue a central bank digital currency (CBDC). As the recent ECB report on open strategic autonomy argues, not issuing an effective digital euro could undermine its international role and create risks to the EU's sovereignty.<sup>518</sup> This is not a scenario that will play out in the next couple of years, but the current proposal for CBDC capped at EUR 3.000 is unlikely to be a game changer in a global context. However, the design of a euro-denominated CBDC for widespread global use carries risks pertaining to money laundering, security, and financial stability. The design of an international digital euro requires prioritizing economic policy objectives.

Finally, the promotion of euro internationalization is always, unavoidably, selective concerning the issuers, economic sectors and financial market segments that it

<sup>516</sup> L Spielberger, L. (2022), The politicisation of the European Central Bank and its emergency credit lines outside the Euro Area, *Journal of European Public Policy*, <https://doi.org/10.1080/13501763.2022.2037688>.

<sup>517</sup> Grünewald, S., Zellweger-Gutknecht, C., and Geva, B. (2021), "Digital euro and ECB powers", *Common Market Law Review*, Vol. 58, No 4, pp. 1029 – 1056. See also the contribution by Corinne Zellweger-Gutknecht to this volume.

<sup>518</sup> ECB, 'The EU's Open Strategic Autonomy from a Central Banking Perspective: Challenges to the Monetary Policy Landscape from a Changing Geopolitical Environment' (n 21); Panetta, F. (2022), 'The digital euro and the evolution of the financial system', Introductory statement by Fabio Panetta, Member of the Executive Board of the ECB, at the Committee on Economic and Monetary Affairs of the European Parliament, <https://www.ecb.europa.eu/press/key/date/2022/html/ecb.sp220615-0b859eb8bc.en.html>.

benefits. In 2016, the ECB introduced the Corporate Security Purchase Programme (CSPP), which focused on the outright purchase of investment-grade corporate bonds. The CSPP was from the start in part conceived as a policy of euro internationalization. CSPP-eligible issuers included corporations whose ultimate parent company was not based in the euro area (for example, the Swiss mining company Glencore and Czech Gas Networks Investments). In promoting the international issuance of euro-denominated bonds, the program also served to promote the EU's capital market union.<sup>519</sup> However, as quickly became clear, the CSPP portfolio was severely biased towards large firms in carbon-intensive industries, which rely extensively on corporate bonds to fund their investments.<sup>520</sup> After a long internal debate on how to mitigate the undesirable side effects of the ECB's policy of market neutrality, the CSPP has now been discontinued.<sup>521</sup> No new programs are currently under debate for promoting euro-denominated corporate bond markets or other forms of international lending. Any policy geared towards promoting euro-denominated loans and bonds will likely run into similar issues.<sup>522</sup>

These four examples illustrate the fundamental obstacle that has to date hindered the ECB from internationalizing its currency: there is no path to euro internationalization that is neutral with regard to the EU's economic policy objectives. The real obstacle to an international euro is the absence of a coherent EU-level strategy.

#### 4.3 Inter-institutional coordination and the secondary mandate

For the euro to become more international, it needs a strategy that sets clear priorities. Some will say that the euro has already become too political and that depoliticizing monetary policy is worth giving up on the ambition of a global role for the European currency. But after a year in which some member states saw inflation peak at over 20 % that is today hardly justifiable as a position that favors price stability. I will now conclude by briefly summarizing a few key insights from the recent literature on the ECB's secondary mandate and how it may inform the design of a strategy for euro internationalization.<sup>523</sup>

The ECB's secondary mandate, as spelled out in Article 127(1) Treaty on the Functioning of the European Union (TFEU), provides a legal basis for the central bank

<sup>519</sup> Braun, B. (2020), 'Central banking and the infrastructural power of finance: The case of ECB support for repo and securitization markets', *Socio-Economic Review*, Vol. 18, No 2, pp. 395–418; de Guindos, L. (2020), 'The ECB's commercial paper purchases: A targeted response to the economic disturbances caused by COVID-19', ECB Blog, April.

<sup>520</sup> Matikainen, S., Campiglio, E., and Zenghelis, D. (2017), 'The climate impact of quantitative easing', Policy Paper, *Grantham Research Institute on Climate Change and the Environment*, London School of Economics and Political Science, p. 36; Schnabel, I. (2020), 'When markets fail: The need for collective action in tackling climate change', European Sustainable Finance Summit, Frankfurt, September. [https://www.ecb.europa.eu/press/key/date/2020/html/ecb.sp200928\\_1~268b0b672f.en.html](https://www.ecb.europa.eu/press/key/date/2020/html/ecb.sp200928_1~268b0b672f.en.html)

<sup>521</sup> Deyris, J. (2023), 'Too green to be true? Forging a climate consensus at the European Central Bank', *New Political Economy*, <https://doi.org/10.1080/13563467.2022.2162869>

<sup>522</sup> Van 't Klooster, J., and Fontan, C. (2020), 'The Myth of Market Neutrality: A Comparative Study of the European Central Bank's and the Swiss National Bank's Corporate Security Purchases', *New Political Economy*, Vol. 25, No 6, pp. 865–879.

<sup>523</sup> See footnote 9. The following summarizes arguments set out in detail in van 't Klooster and de Boer, 'What to Do with the ECB's Secondary Mandate' (n 9); Grünwald and Van 't Klooster, 'New Strategy, New Accountability: The European Central Bank and the European Parliament after the Strategy Review' (n 49).

to take into account priorities that go beyond the narrow price stability objective. The provision places a duty on the central bank to support the broader economic policies of the EU and its Member States (“with a view to” the objectives of the EU spelt out in Article 3 Treaty on the European Union (TEU)). It is controversial whether it allows the ECB to pursue policies that solely have such a supporting role without any monetary rationale. However, we already saw that euro internationalization has profound benefits for the internal and external stability of the currency.

Although the ECB’s *de facto* legal powers are vast, their exercise raises profound questions of legitimacy.<sup>524</sup> It is a widely held democratic principle that a central bank, as an independent agency placed at arms-length from elected government, should avoid making unilateral choices on contested issues of economic policy. Such choices often have implications that go far beyond the monetary and financial expertise of a central bank. The central bank also lacks the democratic legitimacy to make such choices, a concern enshrined in the core values of the EU (Article 2 TEU) and Article 10 TEU’s provision that “[t]he functioning of the Union shall be founded on representative democracy”.

The ECB’s secondary mandate provides a legal basis for the ECB to support euro internationalization, but it does not provide a basis of legitimacy for any specific internationalization strategy. Although Article 127(1) TFEU requires that the ECB acts in support of the EU and its Member States, that provision does not specify either which policies and objectives to support, how to prioritize between policies and objectives, or how the ECB should go about supporting any given priority or objective. It assigns binding duties, but it is unclear how the ECB should act on these duties. The Treaty also explicitly stipulates that the nature of the secondary mandate is supportive: the ECB must “support the general economic policies in the Union”, but that does not mean that the central bank can simply make its economic policy unilaterally.

Rather than setting economic policy objectives alone, inter-institutional coordination provides the ECB with an effective way to reconcile the demands of the secondary mandate with the need for adequate democratic legitimacy. The EU’s political bodies, the European Council, the European Commission and the European Parliament should have a prominent role in developing an adequate strategy for euro internationalization.

The existing Treaties already provide the ECB with ample scope for enhanced democratic authorization.<sup>525</sup> For one, the ECB’s independence does not require the central bank to make policy with an eye to the secondary objectives by itself.<sup>526</sup> Moreover, the EU Treaties provide for ample modalities to coordinate the design of an internationalization strategy for the euro. Article 121(2) TFEU allows the Council to formulate “the broad guidelines of the economic policies of [...] the Union”, which could

---

<sup>524</sup> Friedman, M. (1962), ‘Should there be an independent monetary authority?’, in L. Yeager (ed.), *In Search of a Monetary Constitution*, De Gruyter, Berlin, pp. 219–243; Tucker, P. (2018), *Unelected Power: The Quest for Legitimacy in Central Banking and the Regulatory State*, Cambridge (MA), Harvard University Press; van ‘t Klooster, J. (2020), ‘The Ethics of Delegating Monetary Policy’, *Journal of Politics*, Vol. 82, No 2, pp. 587–599; Downey, L. (2021), ‘Delegation in Democracy: A Temporal Analysis’, *Journal of Political Philosophy*, Vol. 29, No 3, pp. 305–329.

<sup>525</sup> See footnote 10.

<sup>526</sup> See also the contribution to this volume by Alexander Thiele and Klaus Tuori.

be the basis for a common inter-institutional strategy for euro internationalization. Moreover, Article 138 TFEU requires the Council to adopt “a decision establishing common positions on matters of particular interest for economic and monetary union within the competent international financial institutions and conferences” (Article 138(1) TFEU) as well as being allowed to “adopt appropriate measures to ensure unified representation within the international financial institutions and conferences” (Article 138(2) TFEU). In both cases, the proposal is drafted by the European Commission in consultation with the ECB. The European Parliament could also provide input into this process via the yearly resolution on the ECB’s annual report (as foreseen under Article 284(3) TFEU).

Besides these legal and constitutional minutiae, a project of euro internationalization needs a vision of the EU’s long-term future that animates it. This is not a technical issue, but one that raises profound questions for the type of polity that the EU wants to be.

A promising way forward would be to turn the euro into the international funding currency for clean energy investment. The 2021 monetary policy strategy recognizes that the climate and environmental impact of the financial system is today at the core of EU economic policy. Since then, and in light of the catastrophic impact of the energy prices on inflation, that concern has broadened to also include energy policy. A closer link between monetary and energy policy would not be new. Hegemonic empires have historically been closely associated with specific energy forms, inextricably linking monetary power and energy policy.<sup>527</sup> Like the Dutch guilder’s foundation in wind and peat as well as the pound sterling’s rise from coal, the dollar has developed as the currency of oil.<sup>528</sup> Today’s offshore dollar system originated in the recycling of petrodollars earned through oil sales to loans of energy importing countries. The reason that fossil fuel producers continue to invoice their exports to the EU in dollars is closely related to their reliance on dollar funding in global financial markets. In this light, a more ambitious ECB policy for promoting global clean energy financing could be the basis for a coherent and effective strategy for euro internationalization.

---

<sup>527</sup> Smil, V. (2018), *Energy and Civilization: A History*, MIT Press, Cambridge (MA); Thompson, H. (2022), *Disorder: Hard Times in the 21st Century*, Oxford University Press, Oxford.

<sup>528</sup> Mitchell, *Carbon Democracy* (n 28).

# CBDC and monetary sovereignty

Corinne Zellweger-Gutknecht\*

“When two sorts of coin are current in the same nation of like value by denomination, but not intrinsically, that which has the least value will be current, and the other as much as possible will be hoarded [...]”.<sup>529</sup>

“[...] In the extreme, significant use of any CBDC by residents of a foreign country could lead to currency substitution and loss of monetary sovereignty in both the issuing and foreign country [...]”.<sup>530</sup>

## 1 Introduction

In the second quotation, the G7 expressed concerns about the potential threat to states’ monetary sovereignty posed by the issuance and use of central bank digital currencies (CBDCs<sup>531</sup>).<sup>532</sup> A G7 working group responding to Libra (later Diem) had similarly concluded that global stablecoins (GSCs)<sup>533</sup> could cause “currency substitution and could therefore pose challenges to monetary sovereignty”.<sup>534</sup>

Such fears have convinced monetary authorities worldwide that issuing a domestic CBDC might help prevent their currencies from being supplanted by more attractive digital alternatives, thereby safeguarding monetary sovereignty.<sup>535</sup> Similar considerations can also be found in the preparatory material for a digital euro.<sup>536</sup>

---

\* Full Professor of Private Law and Economic Law at the University of Basel, Switzerland.

<sup>529</sup> Macleod, H. D. (1878), *The Theory and Practice of Banking*, Nabu Press, 3rd edn., p. 120.

<sup>530</sup> G7 (2021), Public Policy Principles for Retail Central Bank Digital Currencies, p. 11, available at [https://assets.publishing.service.gov.uk/government/uploads/system/uploads/attachment\\_data/file/1025235/G7\\_Public\\_Policy\\_Principles\\_for\\_Retail\\_CBDC\\_FINAL.pdf](https://assets.publishing.service.gov.uk/government/uploads/system/uploads/attachment_data/file/1025235/G7_Public_Policy_Principles_for_Retail_CBDC_FINAL.pdf).

<sup>531</sup> On CBDC, see, e.g., Panel 4 of the ESCB Legal Conference 2020: European Central Bank (2021), *ESCB Legal Conference 2020*, Frankfurt am Main, February, pp. 168 ff.

<sup>532</sup> G7 (2021) (n 2), p. 11; see also p. 24.

<sup>533</sup> G7 Working Group on Stablecoins (2021), *Investigating the impact of global stablecoins*, October, p. 2: stablecoins with a large and/or cross-border customer base and an according potential global or substantial economic footprint.

<sup>534</sup> *ibid.*, p. iii. See also International Monetary Fund (2020), “Digital money across borders – macro-financial implications”, IMF Policy Paper No. 2020/050, p. 19, p. 38.

<sup>535</sup> Brooks, S. (2021), “Revisiting the monetary sovereignty rationale for CBDCs”, Bank of Canada Staff Discussion Paper 2021-17, December, p. 1; Bank of Canada (2020), *Contingency planning for a central bank digital currency*, February, paras. 2 and 3 scenario 2; Bank for International Settlements (2020), *Central bank digital currencies – Foundational principles and core features*, October, p. 8; Diez de los Rios A. and Zhu, Y. (2020), “CBDC and monetary sovereignty”, Bank of Canada Staff Analytical Note No. 2020-5, February, *passim*; Viñuela, C., Sapena, J. and Wandosell, G (2020), “The future of money and the central bank digital currency dilemma”, *Sustainability* Vol. 12, No. 22, pp. 5, 8, 9.

<sup>536</sup> Council of the European Union (2023), “Impact assessment report”, Commission Staff Working Document ST 11605/23 ADD 2, July, available at [https://eur-lex.europa.eu/legal-content/EN/TXT/?uri=consil%3AST\\_11605\\_2023\\_ADD\\_2](https://eur-lex.europa.eu/legal-content/EN/TXT/?uri=consil%3AST_11605_2023_ADD_2), p. 14: “[...] in the absence of a central bank digital currency in the euro area, future third country CBDCs and non-euro denominated global stablecoins made available to euro area residents may reduce the role of the euro and gradually undermine monetary sovereignty of the Eurosystem.”



This chapter investigates the impact of currency substitution on monetary sovereignty and the potential rationale for the introduction of a CBDC to preserve it. Section 2 outlines the concept of monetary sovereignty on which the subsequent deliberations are based. Section 3 highlights the core objectives of monetary policy, the failure of which risks undermining monetary sovereignty. Section 4 complements this with an exploration of factors which may impede the achievement of monetary policy objectives, before section 5 examines cases in which a CBDC – particularly a digital euro – might aid in defending monetary sovereignty. Macleod's dictum will be addressed in this context. Section 1.7 concludes the discussion.

## 2 Monetary sovereignty

While the precise definition of monetary sovereignty remains disputed,<sup>537</sup> it is widely acknowledged as encompassing more than merely a positive concept. As such, it would simply build on a fixed catalogue of formal state powers in specific financial matters, including the (internal) right to issue a national currency, regulate its use within the territory and conduct monetary policy to achieve certain economic objectives and the (external) competence to set exchange rates.<sup>538</sup>

Monetary sovereignty today also entails corresponding duties to exercise the relevant competencies to achieve policy objectives which adapt to changing social conditions and values over time. The prerogative thereby adds a normative-obligatory component to the traditional static-power-centred building blocks of monetary sovereignty.<sup>539</sup> As Zimmermann has astutely demonstrated, the normative component has its roots in the ultimate locus of power: states in democratic societies are customarily instruments at the service of their people as the true holders of sovereignty.<sup>540</sup> As their living conditions and needs change, so do their values. However, citizens would not cede their sovereign rights and entrust them to their representatives were the latter unable to achieve a normatively just and valuable result. Therefore, the fundamental idea underlying popular sovereignty explains even the recent concept of effective monetary sovereignty, according to which policy objectives must actually be achieved in the sense of a 'command for efficiency'.<sup>541</sup>

A state is (and remains) sovereign in monetary terms if it has the (positive) power, the (normative, value-based) duty and the (effective) ability to achieve its monetary policy objectives directly and to contribute indirectly to its further economic goals through discretionary, autonomous decisions and actions. The two core monetary policy objectives – efficient allocation of capital and smooth settlement of payments – are

---

<sup>537</sup> See, with particular reference to CBDC, Martino, E. D. (2023), "Monetary sovereignty in the digital era", EBI Working Paper Series No. 141, May, passim; Brooks (2021) (n 7), passim; Murau, S. and van 't Klooster, J. (2022), "Rethinking Monetary Sovereignty: The Global Credit Money System and the State", *Perspectives on Politics*, pp. 1-18, passim.; See, in general, van 't Klooster's chapter in this volume.

<sup>538</sup> Zimmermann, C. D. (2013), *A contemporary concept of monetary sovereignty*, Oxford, Oxford University Press, p. 7.

<sup>539</sup> *ibid.*, p. 24.

<sup>540</sup> *ibid.*, p. 22; Annan, K. (1999), "Two concepts of sovereignty", *The Economist*, September 16, passim.

<sup>541</sup> Murau and van 't Klooster (2022) (n 9), p. 2; see also van 't Klooster in this volume.

briefly outlined below, along with the actors responsible for their accomplishment and the instruments utilised.

### 3 Core monetary policy objectives

Since the post-war period, states have pursued economic policy – of which monetary policy is an essential component – under various headings, including ‘embedded liberalism’, ‘price stability’, ‘economic growth’, ‘financial stability’ or ‘sustainability’.<sup>542</sup> Despite this constant state of flux, the core monetary policy goals have remained relatively static and can be crystallised into two. Firstly, capital must be allocated such that an economy’s production potential is optimally exploited.<sup>543</sup> Secondly, money must be available in a quality and quantity that supports (immediately and in the future) the frictionless settlement of an economy’s business transactions. Both core policy objectives, although monetary in nature, extend significantly beyond central banks’ narrower objectives. Therefore, the latter’s role will be discussed separately from other (co-)responsible bodies. For brevity, however, the subsequent outline is unavoidably succinct and cursory.

#### 3.1 Efficient allocation of capital

In principle, the efficient allocation of capital is primarily left to the forces of free competition: market participants allocate capital by providing credit – whether from their own funds or by granting private credit money (which is permitted solely for regulated banks).<sup>544</sup> Put simply, private credit money, created commensurate with the value added by the real economy, contributes as an essential factor to price stability.<sup>545</sup>

Ideally, the state prevents undersupply, booms and busts principally through legislation on the financial sector’s (inherently private) activities. Adequate laws supplemented by regulation, supervision and enforcement should prevent excessive credit growth and risk-taking.<sup>546</sup> Only where this is inadequate should public authorities also intervene directly through economic policy measures, such as monetary policy (or even fiscal policy, which lies beyond the scope of the present discussion). Monetary policy is typically an independent central bank’s responsibility. Its task is to maintain price stability and adjust exchange-rate imbalances. To this end,

---

<sup>542</sup> See, e.g., Murau and van ‘t Klooster (2022) (n 9), p. 10.

<sup>543</sup> On (undesired) output gaps, see, e.g., Jahan, S. and Mahmud, A. S. (2013), “What is the output gap?”, *Finance & Development*, Vol. 50, No. 3.

<sup>544</sup> Murau, S. and Pforr, T. (2020), “What is money in a critical macro-finance framework?”, *Finance and Society*, Vol. 6, No. 1, p. 56; Murau and van ‘t Klooster (2022) (n 9), p. 12.

<sup>545</sup> The precise relationship between (overall) money supply, money velocity, nominal GDP and price levels are likely to remain the subject of epic economic disputes; Jahan and Mahmud (2013) (n 15).

<sup>546</sup> Bank for International Settlements (2023), *Annual Economic Report*, p. 92: “Of course, adequate regulation and supervision are required to prevent excessive credit growth and risk-taking.”

the central bank<sup>547</sup> establishes the conditions under which selected financial market participants can obtain, hold and redeem public money in the form of reserves.<sup>548</sup>

### 3.2 Smooth settlement of transactions

In addition to the optimal allocation of capital, an economy must be capable of settling payments with minimal friction so that goods and services can be exchanged as cost-efficiently as possible. Again, this is largely a function of the market itself. Private credit money in the form of deposits created by regulated banks now accounts for more than 4/5 of the M1 money aggregate (supply available for payment at any time) in most economies.<sup>549</sup> These deposits are mobilised in combination with various payment systems, services and instruments likewise offered by the market, including (instant) credit transfer, e-money payment, internet payment, card payment and mobile payment.

For smooth payments, it is essential that private monies be readily and easily accessible, efficiently transferable and low-risk to ensure a secure value store until the subsequent payment. Moreover, they must be fungible with one another despite having been issued by different market participants (particularly banks). This goal is (again) achieved primarily through prudential legislation and authorities. Where these fail, and in other times of crisis, public financial support is provided as a backstop, albeit with solvency aid being exclusively reserved for the state.

By contrast, the central bank's role is narrower. It provides selected financial market players with public money in the form of reserves to ensure wholesale settlement.<sup>550</sup> It further bridges liquidity gaps, although it must not go beyond emergency liquidity assistance granted against sufficient collateral.<sup>551</sup> It thus contributes to financial stability without bearing the sole responsibility. Furthermore, the central bank issues cash to the public,<sup>552</sup> and thereby ensures a basic supply of easily accessible, risk-free money. Concurrently, given that bank deposits are structured as claims on public money, cash serves as a monetary anchor that underpins people's confidence in private money and other regulated monetary forms.<sup>553</sup> The convertibility at par between private money and the economy's safest form of money – central bank money

---

<sup>547</sup> Others include asset purchases; for criticism and judicial review, see e.g. Huber, P. M. (2019), "The ECB under the scrutiny of the Bundesverfassungsgericht", in European Central Bank (ed.), *Building bridges: central banking law in an interconnected world*, ECB Legal Conference 2019, Frankfurt am Main, December, p. 36 with further references.

<sup>548</sup> See Zellweger-Gutknecht, C., Geva, B. and Grünewald, S. (2021), "Digital Euro, Monetary Objects and Price Stability—A Legal Analysis", *Journal of Financial Regulation*, Vol. 7, No. 2, pp. 295 and 308 with further references.

<sup>549</sup> See, e.g., Zellweger-Gutknecht, C., Geva, B. and Grünewald, S. (2020), "The ECB and €e-banknotes", *Osgoode Legal Studies Research Paper*, August, p. 9 with further references.

<sup>550</sup> See Zellweger-Gutknecht, Geva and Grünewald (2021) (n 20), p. 312; Article 127(4), 4th indent, TFEU (OJ C 326, 26.10.2012, p. 47), Article 17 of the ESCB and ECB Statute (OJ C 202, 7.6.2016, p. 230). Council (2023) (n 8), p. 6.

<sup>551</sup> See, however, below section 4.2.1.

<sup>552</sup> See Zellweger-Gutknecht, Geva and Grünewald (2021) (n 20), p. 300; Article 128(1) TFEU and Article 16 of the ESCB and ECB Statute (n 22).

<sup>553</sup> Council (2023) (n 8), p. 22.

– ensures the singleness of money of a common currency unit and disciplines the banks as issuers of private money: “[u]nsustainably managed banks must expect depositors to withdraw their deposits.”<sup>554</sup>

It is crucial not to confuse anchoring with the state's exclusive provision of a public good or service. Anchoring is suitable in situations in which a market may exist but is ineffective owing to exorbitant rent extraction, risk-taking behaviour, etc., and regulation alone has repeatedly failed to address such issues. The latter is often because financial market participants are agile, capable of sidestepping regulations that impede their activities. In such situations, the state can (rather than simply adding more regulations) decide to offer a good or a service itself, hence establishing a minimum standard that private providers must meet. Otherwise, the public will no longer use the market's solutions, but rather that offered by the state. Anchoring thereby ensures access to essential public goods and services<sup>555</sup> while disciplining the market, and is thus an effective complement to legislation.

## 4 Factors limiting monetary sovereignty

The above section identified four main fields of action through which monetary goals can be achieved efficiently: legislation, monetary policy, anchoring and backstopping. Public money is essential in ensuring the effectiveness of the latter three. Accordingly, factors that negatively affect public money weaken effective monetary sovereignty. The following discussion outlines several such factors, which include classical factors that compromise domestic currency dominance, and others mentioned less frequently in doctrine (or not at all) even though they similarly undermine efficient monetary sovereignty by increasing the risk of financial backstops becoming inevitable.

### 4.1 Classical factors (related to non-domestic currency dominance)

Monetary sovereignty is typically constrained by factors related to the dominance of a non-domestic currency. Such factors include the extent to which the domestic sector (private and public) borrows or even settles in foreign or virtual currency units and the extent to which the exchange rate depends on foreign or virtual currency. The mechanisms by which this undermines sovereignty are well-known and need not be repeated here.<sup>556</sup>

---

<sup>554</sup> See Zellweger-Gutknecht, Geva and Grünewald (2021) (n 20), p. 307.

<sup>555</sup> This includes the basic provision of infrastructure goods and services, which should be available to all sections of the population and regions of the country on equal terms, in good quality and at reasonable prices.

<sup>556</sup> See Fazi, T. and Mitchell, B. (2019), “For MMT”, *Tribune*, 5 June, available at <https://tribunemag.co.uk/2019/06/for-mmt>; Brooks (2021) (n 7), pp. 9 ff. On the consequential hierarchy of monetary sovereignty, see Pistor, K. (2017), “From Territorial to Monetary Sovereignty”, *Theoretical Inquiries in Law*, Vol. 18, No. 2, (and Working Paper No. 591), pp. 491.

## 4.2 Complementary factors (related to financial backstop risks)

At least four additional factors can likewise undermine monetary sovereignty: corporations that are too large to fail; un(der)-anchored private money; systemically important private money of a domestic currency unit; and dependence on foreign-controlled financial infrastructure. All have the potential to push the state into undesirable financial backstops, thereby undermining its ability to act freely and efficiently in monetary matters.

### 4.2.1 Too big or interconnected to fail corporations

Businesses that are too large or interconnected to fail affect monetary sovereignty, particularly in the financial sector. As Monteagudo succinctly observed, “[...] the real challenge for independent monetary policy is to not sacrifice the commitment to preserve monetary stability, in the context of using emergency liquidity facilities; otherwise the central bank [...] becomes an arm of the treasury.”<sup>557</sup> Although his warning emerged a decade ago, its relevance has not waned, as the flare-up of the banking crisis in the spring of 2023 demonstrated. The authorities’ subsequent reaction, which prevented the banks from going bankrupt in a Schumpeterian sense,<sup>558</sup> was ultimately due to their dense interconnectedness with the domestic or international financial sector and – in the case of Credit Suisse – their sheer size, which rendered them (appear) too big to fail. More alarmingly, technology has made bank deposits hypermobile, which has accelerated the recent bank runs and required even larger financial backstops to contain the panic.

Central banks provided emergency liquidity assistance (ELA) on an unprecedented scale, with the Swiss National Bank (SNB) alone lending Credit Suisse approximately USD 165 billion at the height of the crisis.<sup>559</sup> The Swiss government guaranteed an estimated half of this amount. The remainder, however, the SNB loaned against no collateral whatsoever, in complete defiance of Bagehot’s principles (and Monteagudo’s warning).<sup>560</sup> Through emergency legislation, the Swiss Federal Council forced the SNB to take this step,<sup>561</sup> leaving no doubt as to the degree of independence left for the central bank. Similarly, the United States (US) emergency lending programme following the failures of Silicon Valley Bank (SVB), Signature or First

---

<sup>557</sup> Monteagudo, M. (2010), “Neutrality of Money and Central Bank Independence”, in Giovanoli, M. and Devos, D. (eds.), *International Monetary and financial law – The global crisis*, Oxford, Oxford University Press, para. 23.62.

<sup>558</sup> On “creative destruction” see Schumpeter, J. A. (1994) [1942], *Capitalism, Socialism and Democracy*, London, Routledge, chapters 7-8, pp. 82-83.

<sup>559</sup> Neue Zürcher Zeitung (2023), “Der Bund ist sein 100-Milliarden-Risiko gegenüber der Credit Suisse los”, 1 June: “Der Bund ist sein 100-Milliarden-Risiko gegenüber der Credit Suisse los”.

<sup>560</sup> Bagehot, W. (2009), *Lombard Street - A description of the money market*, Seven Treasures Public, [Henry S. King & Co. 1873], p. 78: “in a panic the holders of the ultimate Bank reserve [...] should lend to all that bring good securities quickly, freely and readily” and p. 88 “at a very high rate of interest”.

<sup>561</sup> Federal Council, “Safeguarding financial market stability: Federal Council welcomes and supports UBS takeover of Credit Suisse”, Press release and accompanying documentation, 19 March 2023, available at <https://www.admin.ch/gov/en/start/documentation/media-releases.msg-id-93793.html>.

Republic Bank involved compromises on collateral requirements, which the authorities hardly decided voluntarily (i.e., in a sovereign manner).<sup>562</sup>

## 4.2.2 Unanchored or under-anchored private money

Monetary sovereignty is further at risk where public money can no longer serve as an effective anchor for private money, particularly bank deposits. Without this, the “disciplinary and thus stabilising effect on the banks”<sup>563</sup> is eroded. As noted above, cash has hitherto been the main provider of this anchoring function. Any restriction of cash – for example, through external currency substitution or internal policy constraints – weakens this function and increases the risk of bank failure and backstop compulsion accordingly.

We first referred to the fundamental anchoring function of cash in the research report commissioned under the European Central Bank’s (ECB) Legal Research Programme 2020.<sup>564</sup> In September 2021, we set out the concept in detail,<sup>565</sup> emphasising that the anchor function can only serve its purpose if private monies “are fully and immediately convertible into the anchor” because only then can private monies “also replicate the store of value and unit of account properties of the anchor”.<sup>566</sup> Holding limits undermine this function because bank depositors would experience a ‘lack of cash or a substitute’; thus, the “preventive effect would be far weaker because depositors then would have no equivalent alternative” above such limits.<sup>567</sup>

In November 2021, the ECB began also to discuss the CBDC’s function as a monetary anchor to justify a digital euro.<sup>568</sup> The recent assessment report of the European Commission’s staff on digital euro points includes no fewer than 30 mentions of the anchor function as the first specific goal to be achieved using the digital euro.<sup>569</sup> The reason cited is that “users seem to shift away from cash towards digital payments”, so that cash is “less and less able to act as an ‘anchor’ for commercial bank money.”<sup>570</sup> However, no publication of the ECB, the European Union (EU) co-legislators or their staff to date has referenced our research, let alone discussed the considerable

---

<sup>562</sup> See Federal Reserve System, “Financial Stability”, available at <https://www.federalreserve.gov/financial-stability/bank-term-funding-program.htm>. The Bank Term Funding Program (BTFP) accepts bonds and other securities as collateral and values them at par rather than current market prices.

<sup>563</sup> See Zellweger-Gutknecht, Geva and Grünewald (2021) (n 20), p. 318.

<sup>564</sup> See Zellweger-Gutknecht, Geva and Grünewald (2020) (n 21), pp. 22 and 49.

<sup>565</sup> See Zellweger-Gutknecht, Geva and Grünewald (2021) (n 20), pp. 284 and 293.

<sup>566</sup> *ibid.*, p. 298 (emphasis added).

<sup>567</sup> *ibid.*, p. 307.

<sup>568</sup> Panetta, F. (2021), “Central bank digital currencies: a monetary anchor for digital innovation”, Speech Madrid, 5 November, available at <https://www.ecb.europa.eu/press/key/date/2021/html/ecb.sp211105-08781cb638.en.html>.

<sup>569</sup> Council (2023) (n 8), *passim* and, in particular, p. 28.

<sup>570</sup> *ibid.*, p. 22.

discrepancy between the anchor function and the anchor function as it is envisioned for a digital euro.<sup>571</sup> Sub-section 5.5 addresses this further.

### 4.2.3 Unregulated, systemically important private money of a domestic currency unit

The more widespread the use of unregulated private money, the higher the probability of it ascending to the apex of the financial hierarchy, where systemically significant actors operate. If such monies, even when denominated in domestic currency units, become interconnected with the real economy (e.g. via loans), this raises the likelihood of an ‘elastic’<sup>572</sup> application of the law. In case of a crisis, the government will inevitably – hence no longer truly in a sovereign manner – provide a backstop to prevent economic depression and political unrest.<sup>573</sup>

### 4.2.4 Dependence on foreign-controlled financial infrastructure

Finally, if key financial infrastructure in general and payment schemes and systems in particular are dominated by non-domestic players, monetary sovereignty will be weakened in several respects. States’ ability to autonomously regulate, oversee and supervise activities will be limited, and cooperation in global fora such as the G20, the Committee on Payments and Market Infrastructures (CPMI) and other standard-setting bodies (if available) will not necessarily protect a sovereign’s own (e.g., pan-European) interests as a priority.<sup>574</sup> This again carries the risk of instability and forced financial backstop.

Moreover, it permits rent-extraction at the domestic economy’s expense. The latter may be further burdened by friction costs associated with suboptimal services fuelled by the competition imbalance. Finally, the risk of fine instrumentalisation due to sanctions or other interferences increases significantly when an infrastructure is not in nationally controlled hands.

## 5 A monetary sovereignty rationale for issuing CBDC?

Each monetary jurisdiction will define and weigh the motivations and justifications for a possible CBDC adoption somewhat differently.<sup>575</sup> Rationales may also vary

---

<sup>571</sup> The Regulatory Scrutiny Board (RSB) had explicitly demanded in its first (negative) opinion that the impact assessment of a digital euro “should be more explicit on divergent or opposing views, including by informing on the reasons for the lack of support”: see Regulatory Scrutiny Board (2023), Opinion 2023/0212 (COD) (11605/23 ADD 4, 7 July 2023), p. 12.

<sup>572</sup> Martino (2023) (n 9), p. 13. However, this formula, of the “elastic application of the law” originally coined by Pistor, K. (2013), “A Legal Theory of Finance”, *Journal of Comparative Economics*, Vol. 41, p. 324, is just a euphemism for the fact that the state ultimately breaks the Rule of Law – out of (supposed) sheer necessity – thereby encouraging moral hazard on the part of the apex actors.

<sup>573</sup> Pistor (2017) (n 28), p. 23; Martino (2023) (n 9), p. 23.

<sup>574</sup> Murau and van ‘t Klooster (2022) (n 9), p. 12.

<sup>575</sup> Kosse, A. and Mattei, I. (2023), “Making headway - Results of the 2022 BIS survey on central bank digital currencies and crypto”, BIS papers No. 136, July, p. 5.

depending on whether CBDC is to be made available for exclusive use by regulated financial institutions (wholesale CBDC) or for use by the general public (retail CBDC). A frequently cited reason for the issuance of CBDC is the preservation (and possible strengthening) of monetary sovereignty.<sup>576</sup> Yet, a full exploration of this issue lies beyond the scope of the present study, whose focus is the planned digital euro.<sup>577</sup> The section that follows considers selected encroachments on the monetary sovereignty of the Member States participating in the euro, which a retail CBDC might remedy thanks to its dual role as both a basic public good or service and an anchor. In particular, it examines whether the digital euro, in its proposed form, would be suitable for this purpose.

## 5.1 Cross-border payments and cooperative sovereignty

Many of the existing cross-border payment systems rely on correspondent banking. However, the intensifying crisis in this sector puts a strain on international trade flows and cross-border business in general.<sup>578</sup> In particular, remittances are even more inefficient.<sup>579</sup> However, if states could resolve these long-standing problems on their own, they would surely have done so already.

This leads back to the concept of efficient monetary sovereignty: where constraints prevent autonomous achievement of goals, “sovereignty inherently is bound to be shared and exercised jointly as cooperative sovereignty.”<sup>580</sup> This, however, comes with an essential caveat: cooperative sovereignty is only permissible for promoting values shared by the states involved. Such common values may well include the objective of enabling the smooth processing of cross-border and cross-currency payments. However, when it comes to the associated costs and further impacts, such as exchange rates or privacy, values may quickly diverge again.

---

<sup>576</sup> Council (2023) (n 8), p. 14.

<sup>577</sup> On 29 June 2023, the European Commission adopted three draft proposals related to a digital euro (on the establishment of the digital euro, available at <https://eur-lex.europa.eu/legal-content/EN/HIS/?uri=CELEX:52023PC0369>; on the provision of digital euro services by payment services providers incorporated in Member States whose currency is not the euro, available at <https://eur-lex.europa.eu/legal-content/EN/HIS/?uri=CELEX:52023PC0368>; and on the legal tender of euro banknotes and coins, available at <https://eur-lex.europa.eu/legal-content/EN/HIS/?uri=CELEX:52023PC0364>).

<sup>578</sup> See, e.g., Rice, T., von Peter, G. and Boar, C. (2020), *On the global retreat of correspondent banks*, Bank for International Settlements Quarterly Review March, passim; Wandhöfer, R. and Casu, B. (2018), “The future of correspondent banking cross-border payments”, SWIFT Institute Working Paper 2017-001, passim.

<sup>579</sup> Ardic, O. et al. (2022), “The journey so far - Making cross-border remittances work for financial inclusion”, FSI Insights on policy implementation No. 43, Financial Stability Institute, June, p. 8.

<sup>580</sup> Cottier, T. (2021), “The principle of common concern of humankind” in: Cottier, T. and Ahmad, Z. (eds.), *The Prospects of Common Concern of Humankind in International Law*, Cambridge University Press, p. 57.



Collaborative projects, such as mBridge,<sup>581</sup> Icebreaker<sup>582</sup> or Sela<sup>583</sup> of the Bank for International Settlements (BIS) Innovation Hubs and national central banks, are thus valuable. They explore how to safeguard domestic interests,<sup>584</sup> while central banks can establish (through joint efforts) what has been described in sub-section 3.2 as ‘access to essential public goods and services’ – in such cases, the ability to conduct cross-border and cross-currency payments at a decent price within a reasonable timeframe. Participating states can thus offer a basic joint service that, as an anchor, is not intended to displace private cross-border and cross-currency solutions. Rather, it will help them to better accommodate the user’s needs.

The issue, however, is whether money in the conventional sense (offering both the functions of payment and of storing value in parallel) is truly necessary for the combined purpose of providing essential services and maintaining market discipline. Access to CBDCs already poses substantial challenges in the domestic area, increasing the risk of the banks’ disintermediation. Such challenges are even more accentuated in cross-border areas, with currencies of different exchange rates and financial sectors of varying stability. Therefore, a solution wherein CBDCs would function not as money but as payment railways seems preferable.

For this purpose, the (reverse) waterfall mechanism discussed for a digital euro may offer some inspiration:<sup>585</sup> if an initiated payment surpasses the payee’s defined holding limit, this triggers an automatic transfer to the payee’s private payment account, for example, at a bank or an e-money institution (waterfall). If a payment exceeds the payer’s holding limit, the transfer is triggered from its private payment account (reverse waterfall). With a holding limit set to zero in cross-border situations, CBDCs could act as mere conduits for initiating and executing payments from domestic bank to foreign bank accounts. This would not affect any of the other functionalities tested hitherto, such as the unbundling of the provision of liquidity, access and exchange rate services. CBDC cross-border payment could thus serve as an anchor for (hitherto inefficient) market solutions despite holding limits (unlike at the domestic level, discussed in sub-section 5.5).

---

<sup>581</sup> BIS Innovation Hub Hong Kong Centre et al. (2022), *Project mBridge – Connecting economies through CBDC*, October, available at <https://www.bis.org/publ/othp59.htm>. The project tested the technical feasibility of cross-border and cross-currency transactions between different experimental retail CBDC systems.

<sup>582</sup> BIS Innovation Hub Nordic Centre et al. (2023), *Project Icebreaker – breaking new paths in cross-border retail CBDC payments*, March, available at <https://www.bis.org/publ/othp61.htm>. The project explored a new architecture for cross-border retail CBDCs. It provided PVP across different DLT ecosystems – either (party)oracle-based or via a digital (HTLC/technology-based) escrow. In particular, it unbundled services such as the transfer of money and the foreign exchange function in order to secure fairer pricing.

<sup>583</sup> BIS Innovation Hub et al. (2023), *Project Sela, An accessible and secure retail CBDC ecosystem*, September, available at <https://www.bis.org/about/bisih/topics/cbdc/sela.htm>. The project explored how to create a retail CBDC that is cyber secure and retains selected features of cash. To achieve this, payments were settled directly on the central bank’s balance sheet while an ‘access enabler’ handled all customer-facing services outside its own balance sheet.

<sup>584</sup> For example, foreign banks were restricted in their ability to transfer CBDCs on mBridge. To prevent large quantities of domestic currency from accumulating offshore beyond the central bank’s control, no (domestic nor cross-border) transactions involving a currency foreign to both parties were permitted. Therefore, a domestic bank was always involved in at least one leg of any transaction with regard to the underlying currency: BIS Innovation Hub Hong Kong Centre et al. (2022) (n 53), p. 32.

<sup>585</sup> Council (2023) (n 8), p. 45.

## 5.2 Digitally superior non-euro GSC and CBDC

According to the principle of ‘dollarisation’, foreign, attractive money can displace domestic private and public money. Emerging digital means of payment render currency substitution significantly easier. However, the risk is greatest for countries with high or persistent monetary instability. Even the emergence of foreign CBDCs and GSCs will not fundamentally change this. It is thus realistic to consider the risk of domestic currency substitution to be low in the euro area, even if major third countries, such as China, the USA, or the UK, were to issue a CBDC.<sup>586</sup> Conversely, the issuance of a CBDC would not automatically improve an economy with a weak or unstable monetary system and thus would not be a suitable means of defending monetary sovereignty destabilised by unsustainable fundamentals. Consequently, the euro area is not in need of a CBDC to prevent traditional currency substitution.

This assessment might change, however, were a CBDC to be increasingly in demand domestically due to its digital superiority over national forms of money. Such features might encompass, for example, programmability, purpose-bound payment functionalities,<sup>587</sup> conditionality and straight-through processing – even outside the financial market. Legislation such as MiCA – the EU Regulation on Markets in Cryptocurrencies<sup>588</sup> – is insufficient to minimise the risk in isolation.<sup>589</sup> Therefore, to the extent that traditional cash reserves and bank deposits actually reveal a performance gap, a well-functioning digital euro could strengthen monetary sovereignty. Such an anchor could also motivate issuers of private domestic monies to adapt them to new technologies. Nonetheless, it would not be sufficient to merely improve money technologically; corresponding interfaces with the real economy would also be required and would need to be digitised in parts.

## 5.3 International role of the euro

Since its creation in 1999, the euro has assumed a prominent international role, as its share across various indicators of international currency use continues to average close to 20 %.<sup>590</sup> Nevertheless, concerns have arisen that the emergence of foreign-denominated GSCs and foreign CBDCs might negatively affect this role.<sup>591</sup> Moreover, a scenario with fragmented or grouped currency areas is becoming increasingly realistic: central banks and private assets have been frozen or seized under

---

<sup>586</sup> Council (2023) (n 8), p. 22.

<sup>587</sup> It seeks to combine programmable payment and programmable money and enables money to be directed towards specific purposes, without requiring money itself to be programmed: Monetary Authority of Singapore (2023), “Purpose Bound Money (PBM)”, Technical Whitepaper, June, p. 5, available at <https://www.mas.gov.sg/publications/monographs-or-information-paper/2023/purpose-bound-money-whitepaper>.

<sup>588</sup> Regulation (EU) 2023/1114 of the European Parliament and of the Council of 31 May 2023 on markets in crypto-assets, and amending Regulations (EU) No 1093/2010 and (EU) No 1095/2010 and Directives 2013/36/EU and (EU) 2019/1937 (MiCA Regulation) (OJ L 150, 9.6.2023, p. 40).

<sup>589</sup> While Articles 23(4), 24(3) and 58(3) of MiCA (n 60) allow for limitations on the issuance of stablecoins in non-EU currency that can be used as a medium of exchange, the regulation does not cover foreign CBDC. Capital control also runs counter to liberalised capital accounts (and potentially against IMF agreements) and have not proven efficient against Eurodollars in the past.

<sup>590</sup> European Central Bank (2023), *The international role of the euro*, Frankfurt am Main, June, p. 3.

<sup>591</sup> Council (2023) (n 8), p. 23.

internationally coordinated sanctions. In the future, states may increasingly push for payment in national currency and hold foreign reserves more reluctantly. This may reduce the euro's share in cross-border payments and trade invoicing, in terms of denomination of debt issuances or as a reserve currency.

However, the argument in sub-section 5.2 also applies here: it is unlikely that the euro in its international role will be outcompeted by a digital challenger if the euro area Member States maintain (or restore) a sustainable monetary, economic and fiscal framework. However, depending on their functionalities, foreign CBDCs and GSC might indeed facilitate trade invoicing in their respective currencies at the euro's expense. This risk was rightly deemed highest in small euro area economies.<sup>592</sup>

A digital euro carefully designed for cross-border payments (e.g., in terms of transaction speed and costs) might at least minimise the latter risk. This would further require arrangements and agreements between the ECB and the respective central banks in non-euro area countries and bilateral agreements between the EU and third countries.<sup>593</sup> However, it is unlikely to change much in geopolitical developments. Therefore, while it seems advisable to coordinate the future payment rails between the euro area's most important trade partners, the ECB should abstain from utilising CBDC as a stand-alone catalyst for the euro's internationalisation.

## 5.4 Pan-European card payments

One of the most important – if not the most pivotal – reasons for the introduction of a digital euro is the lack of competition from pan-European players in the card payment field. While the Single Euro Payments Area (SEPA) has created a well-functioning, efficient and fast pan-European credit transfer market,<sup>594</sup> the situation is quite the opposite with card payments: a handful of international card schemes (ICS) process two-thirds of transactions on all EU-issued payment cards.<sup>595</sup> Accordingly, to serve customers from other EU Member States, merchants' options are limited. The lack of competition results in higher fees, which increase the cost of goods and services for individuals. Moreover, foreign control of essential infrastructure entails the risks of forced financial backstopping and foreign instrumentalisation – all at the expense of effective monetary sovereignty. Over the last decade, the co-legislators have considerably adjusted the legal and regulatory framework. Nevertheless, the desired success has hitherto failed to materialise – as has a hoped-for voluntary solution through the initiative of European market participants.

---

<sup>592</sup> *ibid.*

<sup>593</sup> *ibid.*, p. 46; see also the draft regulation Article 19.

<sup>594</sup> Today, consumers can make payments with just one payment account within seconds 24/7 thanks to the Target Instant Payment (TIPS): Council (2023) (n 8), pp. 10 (footnote 25), 48 and 140.

<sup>595</sup> Council (2023) (n 8), p. 48. The low number of domestic schemes that only work nationally is in decline. Merchants who wish to serve customers from other EU Member States in physical shops (PoS) must either accept the handful of ICS or rely on large, often foreign-owned platforms offering digital wallets through which cardholders can initiate payments. E-commerce is similarly dominated by ICS and large platforms. See Council (2023) (n 8), pp. 20; European Central Bank (2019), *Card payments in Europe – current landscape and future prospects: a Eurosystem perspective*, Frankfurt am Main, April, *passim*.

While a digital euro would not establish a ‘SEPA for cards’, it could offer merchants and households an alternative, at least in terms of conditions, thereby reducing market power and dependence on foreign providers and improving the market’s competitiveness. Even the aforementioned holding limits would not affect a digital euro’s suitability, thanks to the associated waterfall and reverse waterfall mechanisms.<sup>596</sup> Ideally, the digital euro could serve as a digital alternative to cash and a catalyst for ongoing innovation in payments in finance and commerce to ‘reduce the fragmentation of the EU retail payments market, promote competition and innovation, including the full roll-out of instant payments and encourage industry initiatives to offer pan-European payment services’.<sup>597</sup>

## 5.5 Complementing cash

The most obvious area of action for a CBDC, however, is to complement cash. As explained above, by issuing cash, the central bank ensures a basic supply of accessible, credit risk-free money and provides a disciplining anchor for all private monies of the same denomination.<sup>598</sup> However, the use of cash – at least, as a means of payment – has long been in decline<sup>599</sup> for three prominent reasons: digitalisation and reinforcing factors, policy constraints and the public’s need for safety.

### 5.5.1 Digitalisation and reinforcing factors

The increased digitalisation of various life domains is leading to a shift in the settlement of transactions towards the digital domain; cash is not a realistic alternative anyway.<sup>600</sup> Trade globalisation has further accelerated this development; given that distant cash payments cannot be made instantaneously, digital solutions have long been the standard. The COVID-19 pandemic that began in 2020 has temporarily reinforced this trend.

Finally, merchants may need to trigger payments in a programmed way – for example, automatically between machines or conditionally (to reassure payer and payee that funds will only be transferred once predefined obligations are met). This requirement, which cash cannot satisfy, is becoming increasingly salient.<sup>601</sup> However, in a recent study of new digital payment methods (discussed with tech-savvy participants), conditional payments were considered nice to have and interesting but not a key driver for the adoption of a new digital payment method.<sup>602</sup> Programmability may also

---

<sup>596</sup> See Council (2023) (n 8), p. 45.

<sup>597</sup> Council (2023) (n 8), p. 7.

<sup>598</sup> See above sub-section 3.2 and Zellweger-Gutknecht, Geva and Grünewald (2021) (n 20), p. 293.

<sup>599</sup> Council (2023) (n 8), p. 13.

<sup>600</sup> This trend is particularly pronounced in the crypto sector, where trading is conducted via new technologies, such as distributed ledger technology (DLT). If the cash leg is not already processed on the same system, at least links (such as APIs and trigger solutions) to traditional electronic payment systems are necessary.

<sup>601</sup> Council (2023) (n 8), p. 18 (conditional payments) and pp. 111, 120, 124, and Annex 8.

<sup>602</sup> Kantar Public (2022), *Study on New Digital Payment Methods (commissioned by the European Central Bank)*, March, pp. 7, 40 and 47.

compromise the fungibility and liquidity of digital money.<sup>603</sup> Moreover, a fine line separates well-intentioned protection (e.g., disaster relief) from paternalism by social scoring, which is intolerable in democracies. Consequently, a digital euro is, in principle, a suitable supplement to cash. However, any form of programmability – even if it concerns only the payment process and not the money itself – must be examined with the greatest transparency and caution.

## 5.5.2 Policy constraints

The decline in the use of cash may also be due to the increasingly cumbersome anti-money laundering/countering the financing of terrorism (AML/CFT) due-diligence requirements.<sup>604</sup> Several Member States have completely banned cash payments above certain thresholds, and an EU-wide cash ceiling is in preparation.<sup>605</sup> Such thresholds have traditionally been applied to cash, despite its status as a legal tender, with reference to recital 19 of Regulation No 974/98. In my opinion, this violates Article 128 (1), third sentence, TFEU, which declares banknotes to be legal tender without restriction, as well as the text and meaning of Regulation No 974/98. Admittedly, the European Court of Justice (ECJ) recently came to the opposite conclusion:<sup>606</sup> the Court used recital 19 as an element of interpretation and understood it in a broad sense, according to which restrictions on cash payments are permissible both for reasons of public order (particularly the fight against crime) and the public interest (e.g., administrative efficiency).<sup>607</sup> However, the ECJ disregarded the historical background of recital 19. By the same token, Advocate General Pitruzzella had simply stated in his opinion that “[t]here is nothing to suggest, even in the preparatory work for Regulation No 974/98, that the recital should only be transitional in scope, as argued by the applicants before the referring court.”<sup>608</sup> This, however, is merely an allegation and is untenable in light of contrary evidence.

The genesis material of Regulation No 974/98 shows unambiguously that the second sentence of recital 19 was only intended to clarify the content of Articles 6 and 9 concerning the transition of national cash to euro cash. According to Article 6, the national currency units became sub-units of the euro, and according to Article 9, national cash retained its legal tender status – but only in its country of origin. The monetary laws of the Member States also remained in force during the transitional period (Article 6). However, several of these national laws banned payment in foreign currency, and such bans henceforth automatically covered payments in (foreign)

---

<sup>603</sup> So-called purpose-bound money tries to overcome this dilemma by combining programmable payment and programmable money. It allows money to be directed towards a specific purpose, without requiring money itself to be programmed: MAS (2023) (n 59), *passim*.

<sup>604</sup> See, e.g., Zellweger-Gutknecht, Geva and Grünwald (2020) (n 21), p. 9 with further references.

<sup>605</sup> Council of the European Union (2022), Proposal for a Regulation on the prevention of the use of the financial system for the purposes of money laundering or terrorist financing (ST 15517/22, 5 December 2022), pp. 9, 20, 52 and draft Article 59 ‘Limits to large cash payments’.

<sup>606</sup> Joined cases C-422/19 and C-423/19, *Johannes Dietrich and Norbert Häring v Hessischer Rundfunk*, ECLI:EU:C:2021:63.

<sup>607</sup> *ibid.*, paras. 64 ff.

<sup>608</sup> Opinion of Advocate General Pitruzzella in Joined Cases C-422/19 and C-423/19, *Johannes Dietrich and Norbert Häring v Hessischer Rundfunk*, ECLI:EU:C:2020:756, footnote 63.

national cash and (if already issued – for practical reasons<sup>609</sup> – before the end of the transitional period) euro cash – although they were the same currency and their legal equivalents. This issue was raised on 10 October 1996.<sup>610</sup>

Already in the draft of 25 October 1996, recital 19 (then recital 14) was supplemented by a third sentence. It addressed precisely such ‘limitations on payments in banknotes and coins’ – and deliberately made no reference to national or euro denomination since national bans potentially covered both.<sup>611</sup> The same sentence then stated that such limitations “are not incompatible with the status of legal tender of euro banknotes and coins.”<sup>612</sup> Here, the recital referred explicitly to the euro denomination because a ban actually contradicted the legal tender status and therefore required a special justification and precondition.

The precondition (stipulated at the end of the third sentence) was that the national currency could still be used – even if it had lost its status as legal tender (which had to occur no later than six months following the transitional period’s conclusion).<sup>613</sup> This was the case as long as national cash could still be exchanged at the national central bank (francs, for example, until February 2005). During this ‘post-transitional’ period, national banknotes and coins were neither ‘legal instruments’ within the meaning of Article 1 (2) of the Regulation, which covers ‘payment instruments other than banknotes and coins’, such as bank deposits, nor were they legal tender. Rather, they were a type of money in their own right, for which recital 14 (today recital 19) consequently created a separate designation: ‘other lawful means for the settlement of monetary debts’. Recital 19 never included any other content that went beyond this transitional and limited post-transitional phase. Therefore, it was never suitable as an indication of justification for cash ceilings for AML or other reasons based on public order or administrative law grounds.

According to the above, the current cash limits lack sufficient basis in primary law. If a digital euro were to be issued on the basis of Article 128 TFEU (for which, however,

---

<sup>609</sup> Draft recital 14 sentence 2 (no longer part of recital 19): (own translation) “For practical reasons, it might be appropriate to introduce euro banknotes and coins shortly before the end of the transitional period”.

<sup>610</sup> European Commission, Propositions de Règlements du Conseil sur l’introduction de l’euro (Art. 109 1 (4) CE) et sur certaines dispositions y afférentes (COM(96)499/3, 10 October 1996), p. 6 re Article 9 (own translation): “This article establishes the territorial limits on the circulation of coins and banknotes in national currencies during the transitional period, despite the fact that they are different images of the same currency and legal equivalents. However, it is not specified what happens to the provisions of the monetary laws of the Member States, which in certain cases prohibit payment in foreign currency. Will national currencies and the Euro be considered as foreign currencies in national monetary laws or not? This raises the more general problem of “legal tender” and the legal acceptability of other monetary instruments to settle a debt.”

<sup>611</sup> The entire Regulation is extremely careful to distinguish when it speaks of euro banknotes and when it mentions ‘banknotes and coins in national currency units’ and when it speaks only of ‘banknotes and coins’ (when national cash and euro cash are to be covered). See European Commission, “Communication to the European Parliament, the Council and the European Monetary Institute Secondary legislation for the introduction of the euro and some provisions relating to the introduction of the euro Proposal for a Council Regulation (EC) on some provisions relating to the introduction of the euro” (COM(96) 499 final, 16 October 1996).

<sup>612</sup> See Council dossier No 11901/96, 25 November 1996, Annex II recital 14 sentence 3, <https://norberthaering.de/wp-content/uploads/2020/06/Entwurf-Kom-25.11.96.pdf> (own translation): “Limitations on payments in notes and coins, established by Member States for administrative reasons, are not incompatible with the status of legal tender of euro banknotes and coins, provided that other lawful means for the settlement of monetary debts are available”.

<sup>613</sup> *ibid.*, recital 14 (today 19) sentence 1: “banknotes and coins denominated in the national currency units lose their status of legal tender at the latest six months after the end of the transitional period”.

the draft regulation does not provide), such limits would likewise be inadmissible. If, however, a digital euro was to be designed as a mere payment instrument based on Article 127 (2), fourth indent, limits could be permissible, even if it were granted legal tender status. Yet, Article 128 TFEU would be violated for other reasons, as will now be shown.

### 5.5.3 Need for safety

One further reason for the decline of cash in circulation is indicated by the so-called ‘paradox of banknotes’ or ‘cash paradox’.<sup>614</sup> It describes how the demand for banknotes as a store of value has grown, while their use as a means of payment has declined as digital payments have increased.<sup>615</sup> This may seem illogical at first glance, as it does not explain why the public continues to store cash anyway – why it incurs the cost of future conversion and does not likewise hold its savings in the more modern, convenient and compliant form of bank deposits.<sup>616</sup>

In this context, the quotation from Macleod mentioned at the outset gives pause for thought. He elaborated on what Thomas Gresham had described three centuries earlier: that good money drives bad money out. With this in mind, the paradox dissolves: apparently, the public perceives a risk that bank deposits may be worth less than cash – though the former are denominated in the same currency unit and instantly convertible at par into cash. The savings-to-payments ratio serves as a fever gauge for this risk – particularly clearly when nominal interest rates are low, as has been the case in recent years.<sup>617</sup>

An excessively accentuated trend in this direction bears the risk of bank disintermediation and bank runs. Since banks may experience considerable outflow of deposits, particularly during times of uncertainty, unlimited access to public cash appears to threaten the stability of the financial system. It may be assumed that the cumbersome handling of cash has led to a pent-up demand in the system, which could be released as soon as public money becomes even more accessible in the form of a CBDC. Accordingly, the temptation to endow the digital euro with holding limits arises. In fact, the draft proposal tasks the ECB in Article 16 to develop instruments “to limit the use of the digital euro as a store of value”. However, this essentially amounts to putting the cart before the horse.

---

<sup>614</sup> Bailey, A. (2009), “Banknotes in circulation – still rising. What does this mean for the future of cash?”, Banknote conference, Washington DC, 6 December 2009, p. 1; Williams, J.C. (2012), “Cash is dead! Long live cash”, Annual Report Essay, Federal Reserve Bank of San Francisco, p. 2; Jiang, J.H. and Shao, E. (2020), “The cash paradox”, *Review of Economic Dynamics*, Vol. 36, p. 177.

<sup>615</sup> European Central Bank (2021), *The paradox of banknotes*, ECB Economic Bulletin, Issue No. 2, Frankfurt am Main; Council (2023) (n 8), p. 143.

<sup>616</sup> The use of storage grows domestically as well as abroad. Despite a pronounced increase of vault cash held by MFIs after the ECB’s deposit facility rate went into negative territory, it can “by no means entirely explain the increase of domestic store of value usage”: ECB *The paradox of banknotes: Understanding the demand for cash beyond transactional use*, European Central Bank (2021), *The paradox of banknotes* (n 87) before Chart 5. Furthermore, even “the low interest environment cannot fully explain the rise in demand. It is possible that other factors, such as increased uncertainty or the ageing of the population, may be at play” (*ibid.* before Box 2).

<sup>617</sup> Jiang and Shao (2020) (n 86), p. 177.

A banking system that is insufficiently robust to digest the introduction of a digital euro – and in particular to counter excessive demand through risk-adequate interest rates on deposits, sustainable risk management and client-friendly access and usability – would be spared by holding limits. Curtailing the anchor would unduly subsidise existing fragility in the financial system – and would thus be a misconceived avoidance of alleged market dominance.<sup>618</sup> It would thus remain the sole task of cash to serve as a monetary anchor for the time being. However, this function is now facing acute threat from the digital euro itself, as its planned features are likely to accelerate the disappearance of cash. It is particularly striking that the status of legal tender is to be granted to both cash and the digital euro and is nonetheless to be structured differently. For both forms of payment, rules on sanctions for infringements will reinforce acceptance of legal tender (which, incidentally, has signified declining quality of and trust in public money throughout history).<sup>619</sup> However, the obligation to accept digital euros is significantly stricter than for cash. According to draft Article 10, the former cannot be unilaterally excluded in advance (while the latter can).

Moreover, the proposed institutional process of ensuring access to cash would be extremely cumbersome and slow:<sup>620</sup> it includes observation by national authorities, the potential introduction of flanking measures, an examination of the latter by the European Commission and a consultation with the ECB. However, by the time all these steps have been completed, a possible negative network effect will have long since and irreversibly displaced cash. Such a conception of the digital euro is contrary to Article 128 TFEU, which must not be undermined by secondary law adopted on the basis of Article 133 TFEU.

## 6 Conclusion

To conclude, foreign CBDCs or GSCs do not pose a threat to a state's monetary sovereignty per se; however, they may impede the attainment of monetary policy objectives when unfavourable economic conditions prompt residents to adopt substitute monies. The introduction of a domestic CBDC as a protective measure is neither effective nor appropriate in such circumstances.

The situation may be different if foreign money is technologically superior, in cases of dependence on foreign-controlled infrastructure and if the state cannot sufficiently control and stabilise financial actors and private monies through legislation, policy measures and financial backstops. Here, the issuance of a domestic CBDC may

---

<sup>618</sup> See further critiques of Grünewald, S. (2023), "A legal framework for the digital euro – An assessment of the ECB's first three progress reports", Economic Governance and EMU Scrutiny Unit, April, p. 11; Hofmann, C. (2023), "Digital Euro – An assessment of the first two progress reports – The case for unlimited holdings of digital euros", Economic Governance and EMU Scrutiny Unit, April, p. 9; Monnet, C. and Niepelt, D. (2023), "Why the digital euro might be dead on arrival", CEPR VoxEU, 10 August.

<sup>619</sup> BIS Innovation Hub and Financial Stability Institute (2021), Summary of the webinar on legal aspects of digital currencies, 26 January 2021, available at [https://www.bis.org/events/210126\\_digital\\_currencies.htm](https://www.bis.org/events/210126_digital_currencies.htm): "History shows that the higher the intrinsic quality and stability of a jurisdiction's monetary framework and public finances, the lesser the need to resort to repressive legal tender legislation."

<sup>620</sup> See Council (2023), Proposal for a Regulation on the legal tender of euro banknotes and coins (ST 11603 2023 INIT, 7 July 2023), p. 5: "National competent authorities will be tasked to monitor access to cash and related cash services".



assure effective monetary sovereignty. However, in a market economy with free competition, the state must exercise restraint. Only if private actors fail to provide their own viable solutions and if milder public actions prove ineffective can a state provide the good or service in question, which then functions both as a basic supply and an anchor for private goods and services. As such, it should neither subsidise nor dominate a market but discipline it through its minimum standards, thus forming a sustainable and inclusive basis for a functioning, fair-market economy.

A digital euro might help defend the monetary sovereignty of the euro area Member States by facilitating cross-border payments as a conduit, mitigating dependence on foreign infrastructure for pan-European payments, serving as a catalyst for the promotion of technologically new payment functionalities and offering a digital complement to cash.

In its planned form, however, the digital euro is not (yet) fit for purpose. Its statutory privilege compared to cash and its holding limits will prevent it from fulfilling its anchoring function. Its issuance would thus weaken rather than strengthen the euro area's monetary sovereignty in the long run.





## Part VI

Filling the gaps: central  
banks, competent  
authorities and legislative  
frameworks

# Filling the gaps: central banks, competent authorities and legislative frameworks: an introduction

Edouard Fernandez-Bollo\*

Mandatory consultations are delicate legal provisions. Their aim is to strike a balance between, on the one hand, a clear differentiation of legal roles, in particular keeping decision-making powers in the most legitimate hands, and, on the other hand, the need to ensure that the views of other important stakeholders are duly taken into account in the decision-making process. One consequence of these balancing acts is increased procedural complexity, because of the need to factor in sufficient time to conduct and then discuss the outcomes of these consultations. It is thus important to build in reality checks on the justification for, and effectiveness of, these provisions. 25 years after the creation of the ECB – and almost ten years after the transfer to the ECB of essential prudential supervision tasks – we now have a very good opportunity to perform this kind of analysis.

I will endeavour to contribute to this discussion by offering some considerations based on concrete examples of the benefits of the mandatory opinions of the ECB – for the consulting authority, the consulted authority (in this case the ECB) and other stakeholders. Practical experience being paramount to this kind of “lessons learned” exercise, I will concentrate on issues which are linked to my field of activity, while also highlighting that very similar analysis could be done from the point of view of the ECB’s other core functions. Indeed, some of the examples I will mention raise questions of common interest to many ECB business areas.

Before presenting these cases, let me however mention two specific legal features of ECB Banking Supervision, rightly underlined by many commentators<sup>621</sup>, which accord particular importance to the consultation procedure for this mission.

First, in banking supervision, the ECB plays an essential implementation role – as it has taken up the most important supervisory tasks in the banking union – but it has extremely limited regulatory powers. This implementation role involves, among other things, taking a large number of legal decisions on a day-to-day basis<sup>622</sup> in order to implement the applicable regulations. However, the power to regulate is, at the European level, essentially in the hands of the co-legislators and, for more technical aspects, the European Banking Authority. The ECB may only use its competence to

---

\* Member of the Supervisory Board of the European Central Bank since 2019.

<sup>621</sup> See, for example, Bassani, Giovanni (2019), *The Legal Framework Applicable to the Single Supervisory Mechanism: Tapestry or Patchwork?*, Wolters Kluwer, Alphen aan den Rijn, in particular Chapter 3, Section 3.02 and seq, p.73.

<sup>622</sup> Some 2,582 supervisory decisions were taken in 2022 (see the ECB Annual Report on supervisory activities 2022), i.e. approximately 10 decisions per working day.

adopt regulations to the extent necessary to organise or specify the arrangements for carrying out the supervisory tasks conferred on it.

Second, this supervisory competence also implies that the ECB has to apply the national legislation transposing the EU directives, as well as the national options granted to the Member States by the EU regulations. However, it does not have an institutional role in the adoption of the national provisions that it implements<sup>623</sup>. Indeed, Article 1(2) of Decision 98/415/EC<sup>624</sup> governing these consultation processes provides expressly that “Draft legislative provisions shall not include draft provisions the exclusive purpose of which is the transposition of Community directives into the law of Member States”. The rationale for this provision was that the ECB is already consulted on the adoption of the directives, so it seemed that there was no need to duplicate this for the implementing texts. However, this provision was elaborated at a time when the ECB had no direct competence to apply these national laws. While there is, of course, also the possibility of an own-initiative opinion, the fact remains that national authorities have no obligation to consult the ECB on matters where their possible divergence could create a serious problem for ECB Banking Supervision. Consultation of the ECB is indeed the only mechanism that can ensure the authority that will have to concretely apply the piece of law is fully aware of it and can provide the national legislator/regulator with its analysis of the possible consequences of the draft law – also taking into account our Europe-wide experience. This makes it all the more essential to be sufficiently involved, at least at the level of EU primary legislation, and explains the main features of ECB opinions in this field. Their purpose is both to deliver a clear message on European harmonisation and to build upon our technical expertise to suggest concrete ways to implement it. We can see these features in three particularly important opinions adopted recently by the ECB in this area.

## 1 Banking package

The first important opinion concerned the banking package, that is, the amendments proposed to both the Capital Requirements Regulation and the Capital Requirements Directive (CRR3 and CRD6)<sup>625</sup>. The Commission proposals put forward in October 2021 aimed to transpose into European Law the main features of the revised Basel Framework for the capital requirements applicable to banks (Basel III<sup>626</sup>) and to integrate other updates to the European rulebook. It is thus the biggest evolution of

---

<sup>623</sup> For instance, of the 2,582 supervisory decisions referred to in footnote 2, 44.9% related to fit and proper assessments and 9.7% to the use of national powers; therefore, the number of ECB supervisory decisions applying national laws is clearly more than half of the total number of decisions taken in 2022.

<sup>624</sup> Decision 98/415/EC of the Council of the European Union of 29 June 1998 on the consultation of the European Central Bank by national authorities regarding draft legislative provisions (OJ L 189, 3.7.1998, p. 42).

<sup>625</sup> See [https://finance.ec.europa.eu/publications/banking-package\\_en](https://finance.ec.europa.eu/publications/banking-package_en): Proposal for a REGULATION OF THE EUROPEAN PARLIAMENT AND OF THE COUNCIL amending Regulation (EU) No 575/2013 as regards requirements for credit risk, credit valuation adjustment risk, operational risk, market risk and the output floor and Proposal for a DIRECTIVE OF THE EUROPEAN PARLIAMENT AND OF THE COUNCIL amending Directive 2013/36/EU as regards supervisory powers, sanctions, third-country branches, and environmental, social and governance risks, and amending Directive 2014/59/EU.

<sup>626</sup> See <https://www.bis.org/press/p171207.htm>: the last revisions adopted in December 2017 completed the global regulatory framework for more resilient banks and banking systems adopted by the Basel Committee on Banking Supervision, hosted by The Bank for International Settlements (BIS).

the essential rules that banking supervision in the European Union has had to apply since the inception, ten years ago, of the Single Supervisory Mechanism. Therefore, there could not be a more suitable occasion on which to contribute our experience. In these opinions, the ECB expressly mentioned the particular importance of the issues addressed and also separately provided a substantial, technical working document with suggested amendments and the rationale behind them. Without entering into any details, it is possible to summarise the main messages contained in these opinions in the following two points<sup>627</sup>.

First, on the technical part of the capital requirements, the ECB underlined the importance for the European Union of preserving the robust international standards for banks that are an essential public good for a major international banking market. We thus recommended eliminating any gaps between the EU rules and the original Basel III standards, and that any deviations should be strictly temporary. This seems indeed to us the best way to preserve financial markets' trust in EU banks whose international activity is particularly important, and to prevent future crises through a safer and sounder financial system that supports the economy in good times and bad.

Second, the other, more institutional provisions aim at further strengthening the EU prudential framework. They do so by tackling emerging risks to banks (especially those stemming from the climate crisis) and through further harmonisation, both of national rules in key areas of bank governance and of the supervisory powers granted to the authorities. Not surprisingly perhaps, the divergences among national laws transposing EU directives are most visible on issues that are not specific to banking, but relate to more general areas of law where there are different legal traditions and histories in Europe. Examples include company laws on the appointment of managers and the role and design of the governing bodies of corporations, and administrative laws on the powers of sanction conferred upon supervisors. The ECB welcomed and supported these CRD provisions, which will allow a more harmonised treatment of banks across the EU, regardless of the country in which they are headquartered. We will be in a position to ensure that the same infringements can be sanctioned in the same way, and that the same rules will also apply to the screening of key managers before they take up their positions in all the most important European banks.

The global ECB message conveyed by these opinions on the banking package is thus that reducing the riskiness of European banks' exposures and achieving greater harmonisation in rules will make ECB Banking Supervision more effective, and in turn deliver a banking sector that is more integrated and more resilient. Given the technicality and complexity of the matters involved, these broad messages were elucidated further in a great number of detailed drafting proposals, aiming to provide a precise basis for a fruitful dialogue with the co-legislators. This dialogue is usually pursued until the end of the co-legislation process. It is, of course, only up to the co-legislators to discuss whether or not to incorporate – fully or partially – the ECB's suggestions. However, it is our experience that whatever the other factors that may determine their final stance, they appreciate this independent, technical contribution to the effectiveness of the regulation and the opportunity that it gives them to have

---

<sup>627</sup> See also the ECB blog post published about these opinions: <https://www.bankingsupervision.europa.eu/press/blog/2022/html/ssm.blog220428-6fc9bc7bb0.en.html>.

informed discussions on these issues. In matters such as banking prudential regulation, the financial stakes can be very high. In addition, the perceived interest of many parties (the industry, clients and companies) and the many specificities linked to national contexts or business models may lead to different points of view. We firmly believe that, in the discussions of the banking package, the ECB's contribution has contributed to preserving the global perspective on financial stability and the promotion of European integration.

## 2 Anti-money laundering package

The same perspectives are at the core of the messages the ECB wanted to deliver with its opinion on another package of EU legislation, the anti-money laundering (AML) package proposed by the European Commission<sup>628</sup>. The ECB is not tasked with supervising banks' compliance with rules that aim to prevent money laundering and terrorist financing. Nonetheless we fully realise, in particular through our direct prudential supervisory role, the danger that money laundering and terrorist financing risks pose to the sustainability of banks and to public trust in the banking sector. We are also conscious of the links between anti-money laundering (AML) supervision and prudential supervisory tasks – with both supervisors having to cooperate on a number of essential tasks, including granting and withdrawing authorisations, and appraisal of management, governance and shareholders.<sup>629</sup> This is why the ECB welcomes the Commission's proposal published in July 2022 to set up an EU AML Authority. It will help to ensure that anti-money laundering/countering the financing of terrorism (AML/CFT) rules are applied more effectively and consistently across countries and so can be consistently taken into account by the ECB in its prudential role. This is coupled with another substantial change – transforming most of the requirements addressed to private entities in the AML Directive into a directly applicable EU Regulation. This represents a concrete and welcome sign of integration to all European citizens as, for instance, in the future the same rules on identification (the "know your customer" requirements) will apply in all Member States of the European Union.

In this case, too, the wider message of the ECB's opinion is accompanied by concrete proposals to the co-legislators showing the willingness of the ECB to contribute to the efficiency of the legislative framework proposed. This relates essentially to the links

---

<sup>628</sup> See [https://finance.ec.europa.eu/publications/anti-money-laundering-and-countering-financing-terrorism-legislative-package\\_en](https://finance.ec.europa.eu/publications/anti-money-laundering-and-countering-financing-terrorism-legislative-package_en); this package presented on 20 July 2021 contains a key element for European integration, the creation of a new EU authority that will be the central authority coordinating national authorities to ensure the private sector correctly and consistently applies EU rules. It also includes a new regulation that will contain directly applicable rules, including in the areas of customer due diligence and beneficial ownership, and the setting-up of an EU-wide limit of €10,000 for large cash payments. The package also includes a new directive replacing the existing Directive 2015/849/EU, with rules on national supervisors and financial intelligence units in Member States, as well as a revision of Regulation 2015/847/EU on the transfer of funds that will make it possible to trace transfers of crypto-assets.

<sup>629</sup> See, for instance, the recent ruling of the ECJ in the case of *Versobank* ([https://curia.europa.eu/juris/document/document\\_print.jsf?mode=lst&pageIndex=0&docid=277075&part=1&doclang=EN&text=&dir=&occ=first&cid=103654;C-803/21 P](https://curia.europa.eu/juris/document/document_print.jsf?mode=lst&pageIndex=0&docid=277075&part=1&doclang=EN&text=&dir=&occ=first&cid=103654;C-803/21 P)) confirming that, although the Member States remain competent to implement AML/CFT provisions, as expressly provided for in recital 28 of the SSM Regulation, the ECB has exclusive competence to withdraw authorisations for all credit institutions, irrespective of their significance, also for serious breaches of AML/CFT provisions.



between AML and prudential supervision. The new approach to supervising AML/CFT risks should indeed improve the efficiency of the cooperation among all parties involved. The new authority should not be an additional layer on top of the existing AML/CFT supervisors, rather it should play a central role in strengthening cooperation and facilitating information flows between all regulatory and supervisory authorities involved. To that end, the ECB is fully prepared to play its part and would welcome the creation of a new central data hub, to ensure improved collection and use of all available information on money laundering and terrorist financing risks. This central data hub could also integrate information collected from and provided to prudential supervisors.

It is interesting to note that these opinions have been particularly successful in allowing fruitful contact with all the co-legislators, even on those subjects where the ECB usually participates less actively. Facilitating the discovery of channels of communication and interaction at an early stage of legislative discussions is a benefit that is very much appreciated from an operational perspective.

### 3 Crisis management and deposit insurance package

Finally, the third recent example illustrating the importance of the ECB opinions and that deserves to be pointed out relates to the Commission's recent proposals to amend the EU bank crisis management and deposit insurance framework, or the CMDI package<sup>630</sup>. This opinion was drafted swiftly by the ECB, as it was published on 3 July 2023 regarding proposals published by the European Commission on 18 April of the same year. This is already a mark of the importance of these pieces of legislation for the ECB. Indeed, the ECB wanted to show by example that a European institution where the diversity of perspectives that come together to make up the European banking union are well represented could reach a joint assessment on these very delicate topics. There are few issues as complex and with such potentially major consequences as the management of a banking crisis, since it is well known that in Europe there are stakeholders with very different views on the best way through. The joint assessment is also a public commitment to contribute to finding sound and independent advice on how to further increase the efficiency of this essential framework. Furthermore, the ECB has also announced that it stands ready, in close cooperation with the Single Resolution Board (SRB), to provide further technical input on proposals to ensure a consistent and workable framework. Indeed, enhancing the resilience of crisis management in Europe has been clearly pointed out by the Eurogroup as a key milestone for making progress on the other outstanding elements to strengthen and complete the banking union<sup>631</sup>. In addition, the banking turmoil

---

<sup>630</sup> See [https://ec.europa.eu/commission/presscorner/detail/en/ip\\_23\\_2250](https://ec.europa.eu/commission/presscorner/detail/en/ip_23_2250): this package contains proposals to adjust and further strengthen the European Union's existing bank CMDI framework, with a focus on the treatment of medium-sized and smaller banks. It encompasses amendments regarding the Bank Recovery and Resolution Directive (BRRD) 2014/59/EU (as regards early intervention measures and conditions for resolution and financing of resolution action), the Single Resolution Mechanism Regulation (806/2014/EU) and the Directive on deposit guarantee schemes (DGSD) 2014/49/EU, in order to further harmonise their preventive and alternative interventions.

<sup>631</sup> See the Eurogroup statement of 16 June 2022, <https://www.consilium.europa.eu/en/press/press-releases/2022/06/16/eurogroup-statement-on-the-future-of-the-banking-union-of-16-june-2022/>.

outside the EU in March 2023 has also underlined the importance of having a solid and fully credible framework in place to avoid any contagion risk. Facilitating a wider application of the resolution framework within the banking union and developing the coordination between the SRB and the national deposit guarantees schemes will clearly lead to enhanced confidence in the banking system.

These three examples demonstrate some of the many ways in which the consultative function of the ECB is important not only for the ECB itself, as the consulted party that has an opportunity to express its views, but also for the consulting authorities and the other stakeholders of financial regulation. For supervisory issues, ensuring good coordination between regulation and supervision is crucial for all the parties involved, namely European co-legislators and national regulators, other supervisors, regulated industries and the public at large which is served by these industries. ECB opinions are an essential tool for these interactions – and not just a piece of advice hanging in the air, or only used to tick the box on a procedural requirement – because they enable concrete dialogue with all these counterparties. They allow us to explain supervisory needs and points of view, both at the level of principles and in detail, increasing the transparency and accountability of the ECB's approaches to a very diverse range of issues.

## 4 Conclusions

Let me draw some conclusions that could be of interest also in relation to the other issues mentioned in the contributions of the participants in this panel.

First, since the number of opinions is essentially driven by the number of regulatory initiatives, it is not surprising that this number can vary at different points in the regulatory cycle. For ECB Banking Supervision, on the one hand, we are at the end of the post-crisis regulatory cycle. Therefore we do not expect there to be many texts as essential for us as the present banking package, which we will be consulted on over the next few years. On the other hand, the need to address emerging risks, such as those concerning the climate or the development of new digital technologies, is creating a new set of regulations which are crucial for the future of banking. Therefore we are developing a new set of interests that are leading us to also draft opinions on matters which were not previously as high on the list of priorities for central banks and banking supervisors. One of the most recent examples is the opinion on the proposal for a directive on corporate sustainability due diligence<sup>632</sup>. A previous interesting example was the opinion on the proposal for a regulation laying down harmonised rules on artificial intelligence. In its opinion, the ECB grounded its competence to deliver an opinion specifically on Articles 127(4) and 282(5) of the Treaty on the Functioning of the European Union, as the proposed regulation contained provisions

---

<sup>632</sup> See [https://www.ecb.europa.eu/pub/pdf/legal/ecb.leg\\_con\\_2023\\_15.en.pdf](https://www.ecb.europa.eu/pub/pdf/legal/ecb.leg_con_2023_15.en.pdf), OPINION OF THE EUROPEAN CENTRAL BANK of 06 June 2023 on a proposal for a directive on corporate sustainability due diligence (CON/2023/15).

relevant to the ECB's tasks concerning the prudential supervision of credit institutions<sup>633</sup>.

Second, what matters most in this instrument of soft law is the quality of the dialogue and interactions that it allows. If we were to have a proxy for this, maybe the best suggestion would be the number of modifications that have used ECB opinions as one input – although, of course, they were not necessarily aligned with the ECB's drafting proposals. While we do not have precise metrics to measure this, our recent experience is that, quite often, our proposals are indeed considered during discussions among European co-legislators. Our experience with the national legislators is more mixed, given also the fact that in the present state ECB provides rather general observations than detailed drafting to them. as the ECB there are much less detailed proposals in these cases).

Finally, the area in which more progress may be considered necessary is the transposition of EU directives to be applied in the supervision of significant institutions in the banking union. The optimal situation would require a modification of the Council Decision of 29 June 1998. In our view this would be fully justified. The creation of the banking union was not on the cards when the Decision was adopted in 1998, and it is precisely in these cases that consultation with the ECB should be considered a substantive procedural requirement in the sense of the case law of the European Court of Justice. This progress on European harmonisation is still pending. Nevertheless, it is already our expectation and objective that we should be put in a position to issue own-initiative opinions or involved as much as possible in other ways, despite the present state of the law, where consultation of the ECB is not mandatory for these pieces of regulation. This would enable us to ensure the best possible concrete outcomes for supervision inside European banking union.

---

<sup>633</sup> See <https://eur-lex.europa.eu/legal-content/EN/TXT/PDF/?uri=CELEX:52021AB0040>, OPINION OF THE EUROPEAN CENTRAL BANK of 29 December 2021 on a proposal for a regulation laying down harmonised rules on artificial intelligence (CON/2021/40) (2022/C 115/05).

# ECB opinions on national legislative proposals: practice to date and outlook

Diane Fromage\*

## 1 Introduction: applicable legal framework and purpose of ECB opinions

The European Central Bank (ECB) (and the European Monetary Institute before it) has always had to be consulted on “any proposed Union act in its fields of competence” as well as “by national authorities regarding any draft legislative provision in its fields of competence”.<sup>634</sup> However, academic research so far has largely neglected the ECB’s advisory function towards national institutions;<sup>635</sup> this contribution intends to fill in this gap.

To this end, the introduction first recalls what the applicable legal framework is, and what purpose ECB opinions on national pieces of legislation serve. The second section of this contribution then turns to practice to date (section 2), before the last concluding part draws some conclusion and adopts a forward-looking stance (section 3).

### 1.1 Applicable legal framework

As already noted, national institutions are under the obligation to consult the ECB “regarding any draft legislative provision in its fields of competence”. However, this obligation is not absolute as it applies “within the limits and under the conditions set out by the Council accordance with the procedure laid down in Article 129(4) [Treaty on the Functioning of the European Union (TFEU)]”.<sup>636</sup> Upon being consulted by a national institution, the ECB “may give an opinion”.<sup>637</sup> Where it decides not to adopt an opinion, a letter is adopted. Furthermore, this obligation set on national authorities to consult the ECB is complemented by its possibility to “submit opinions to the appropriate Union institutions, bodies, offices or agencies or to national authorities on matters in its fields of competence”.<sup>638</sup> As a consequence, the ECB may compensate

---

\* Professor of European Law and Deputy Director, Salzburg Centre of European Union Studies, University of Salzburg & Affiliated Researcher, Sciences Po Law School, Paris.

<sup>634</sup> Article 127(4) TFEU and Article 282(5) as well as Article 4 ESCB Statute.

<sup>635</sup> Notable exceptions to this are: A. Arda, “Consulting the European Central Bank. Legal aspects of the Community and national authorities’ obligation to consult the ECB pursuant to article 105(4) EC”, *Euredia*, 2004, Vol. 1, pp. 111-152; S. E. Lambrinoc, “The legal duty to consult the European Central Bank. National and EU consultations”, ECB Legal Working paper series No 9, 2009; R.S. Smits, *The European Central Bank. Institutional aspects*, Wolters Kluwer, 1997, pp. 211 ff; Ms Würtz, *The legal framework applicable to ECB consultations on proposed Community acts*, *Euredia*, 2005, Vol. 4, pp. 283-327.

<sup>636</sup> Article 127(4) TFEU.

<sup>637</sup> Article 282(5) TFEU.

<sup>638</sup> Article 127(4) TFEU.

for national authorities' (genuine or deliberate) failure to consult it. However, for the ECB to be fully capable to compensate for national authorities' negligence, this would imply that it has to scrutinise legislative developments happening in all 27 Member States, which could put a heavy burden on it, or that it relies on information it may gain through other channels.

The modalities of application of this obligation for national authorities to consult the ECB were detailed in a decision of the Council adopted in 1998.<sup>639</sup> It defines 'draft legislative provisions' as "any such provisions which, once they become legally binding and of general applicability in the territory of a Member State, lay down rules for an indefinite number of cases and are addressed to an indefinite number of natural or legal persons";<sup>640</sup> hence, the definition adopted is rather broad. This Council Decision additionally distinguishes between euro area Member States, i.e. 'participating Member States', and non-euro area Member States, whereby non-participating Member States shall also consult the ECB in regard to draft legislative provisions on instruments of monetary policy. All Member States shall consult the ECB on "any draft legislative provisions within its field of competence pursuant to the Treaty and in particular: currency matters, means of payment, national central banks, the collection, compilation and distribution of monetary, financial, banking, payment systems and balance of payments statistics, payment and settlement systems, [and the] rules applicable to financial institutions insofar as they materially influence the stability of financial institutions and markets."<sup>641</sup> This list appears to be rather comprehensive and should, furthermore, not be viewed as being exhaustive.<sup>642</sup> Moreover, following the creation of the Banking Union and the introduction of the Single Supervisory Mechanism headed by the ECB, its advisory role in the area of prudential supervision has become much more important.

According to the Decision, the ECB is also to "immediately [...] notify the consulting authority whether, in its opinion, such provision is within its field of competence" upon receiving the draft legislative proposal.<sup>643</sup> The ECB shall not be consulted on national pieces of legislation whose main purpose is to transpose a European Union (EU) directive. This is because the ECB has already been consulted on the draft EU directive, and the ECB considers that the same exemption also applies to national measures implementing EU regulations unless they "have an impact on matters falling within the ECB's field of competence which is different from the impact of the regulation itself".<sup>644</sup> This notwithstanding, the ECB has invited national authorities to consult it on national measures transposing some directives, or has issued own initiative opinions in such cases.<sup>645</sup> Member States authorities may, too, decide to consult the ECB voluntarily, and the ECB generally accedes to such requests if they relate to the ECB's fields of competence. Additionally, the transposition of directives has already drawn

---

<sup>639</sup> Council Decision of 29 June 1998 on the consultation of the European Central Bank by national authorities regarding draft legislative provisions (98/415/EC) (OJ L 189, 3.7.1998, p. 42).

<sup>640</sup> *ibid.*, Article 1.

<sup>641</sup> *ibid.*, Article 2(1).

<sup>642</sup> *ibid.*, Recital 3.

<sup>643</sup> *ibid.*, Article 2(3).

<sup>644</sup> European Central Bank, *Guide to consultation of the European Central Bank by national authorities regarding draft legislative provisions*, 2015, p. 16.

<sup>645</sup> *ibid.*

the ECB's attention. This was for instance the case in 2018 when the ECB flagged the Directive (EU) 2016/1148 of the European Parliament and of the Council of 6 July 2016 concerning measures for a high common level of security of network and information systems across the Union as a horizontal issue.<sup>646</sup> The ECB examined the extent to which Member States failed to their obligation to consult it owing to the impact of the transposition measures on its competences in the areas of National Central Banks (NCBs), payment and settlement systems and/or the ECB's tasks concerning the prudential supervision of credit institutions. This led it to send a non-consultation letter to the Republic of Cyprus.

It is furthermore interesting to note that the ECB is not to be consulted on draft legislative provisions implementing recommendations of the European Systemic Risk Board (ESRB).<sup>647</sup> The ESRB monitors the follow up to its recommendations,<sup>648</sup> hence why the ECB need not be consulted.<sup>649</sup> This approach appears particularly well-suited considering the large role played by the ECB within the ESRB.<sup>650</sup>

As regards the modalities of the ECB's consultation, the consulting authority "may, if they consider it necessary" (i.e. can but must not) set a time limit for the ECB to deliver its opinion. It may not be of less than one month "from the date on which the President of the ECB receives notification",<sup>651</sup> except in cases of 'extreme urgency' where the delay may be of less than one month. In those cases, the consulting authority shall "state the reasons for the urgency".<sup>652</sup> The ECB may request an extension of up to four weeks, which "shall not be unreasonably declined by the consulting authority".<sup>653</sup> After the time limit has expired, the absence of an ECB opinion shall not prevent national authorities from acting.<sup>654</sup> However, if the ECB still adopts an opinion at a later stage, it shall be brought to the knowledge of the adopting authority as appropriate. It is remarkable that this very short time limit (one month formally, oftentimes six weeks in practice<sup>655</sup>), during which the opinion must not only be prepared, but also circulated among all Governing Council members prior to its adoption, does not seem to create any difficulties in practice. Perhaps, the fact that Governing Council members already receive the requests for an opinion early on facilitates the procedure, as they already have the chance to familiarise themselves with the matters at stake prior to receiving the draft opinion.<sup>656</sup> This notwithstanding,

<sup>646</sup> European Central Bank, *Annual report 2018*, available at <https://www.ecb.europa.eu/pub/annual/html/ar2018-d08cb4c623.en.html#toc44>.

<sup>647</sup> European Central Bank, *Guide to consultation of the European Central Bank by national authorities regarding draft legislative provisions*, 2015, p. 17.

<sup>648</sup> Regulation (EU) No 1092/2010 of the European Parliament and of the Council of 24 November 2010 on European Union macro-prudential oversight of the financial system and establishing a European Systemic Risk Board (OJ L 331, 15.12.2010, p. 1), Article 3(2)(f).

<sup>649</sup> European Central Bank, *Guide to consultation of the European Central Bank by national authorities regarding draft legislative provisions*, 2015, p. 17.

<sup>650</sup> See further on this: D. Segoin, The accountability of the ECB as a subsidiary or secondary macroprudential supervisor, *Maastricht Journal of European and Comparative Law*, forthcoming.

<sup>651</sup> Council Decision of 29 June 1998 on the consultation of the European Central Bank by national authorities regarding draft legislative provisions (98/415/EC) (OJ L 189, 3.7.1998, p. 42), Article 3(1).

<sup>652</sup> *ibid.*, Article 3(2).

<sup>653</sup> *ibid.*, Article 3(3).

<sup>654</sup> *ibid.*, Article 3(4).

<sup>655</sup> European Central Bank, *Guide to consultation of the European Central Bank by national authorities regarding draft legislative provisions*, 2015, p. 22.

<sup>656</sup> *ibid.*, p. 23.

there have been cases where Member States did not wait for the ECB's opinion, or submitted their request for an opinion at too late a stage in the legislative procedure for it to be taken into consideration.<sup>657</sup>

Finally, Member States have the obligation to ensure 'effective compliance' with the Decision, that is they "shall ensure that the ECB is consulted at an appropriate stage enabling the authority initiating the draft legislative provision to take into consideration the ECB's opinion before taking its decision on the substance [Furthermore, Member States are to ensure] that the opinion received from the ECB is brought to the knowledge of the adopting authority if the latter is an authority other than that which has prepared the legislative provision concerned".<sup>658</sup>

The ECB's Rules of Procedure detail how opinions are to be adopted in practice. They define that it is the Governing Council's responsibility, although the possibility exists "in exceptional circumstances and unless not less than three Governors state their wish to retain the competence of the Governing Council for the adoption of specific opinions" for the Executive Board to adopt these opinions.<sup>659</sup> Where the Executive Board adopts the opinions, it shall do so "in line with comments provided by the Governing Council and taking into account the contribution of the General Council". Further to this, the possibility exists for the Executive Board to "finalise ECB opinions on very technical matters and to incorporate factual changes or corrections". The ECB President signs the opinions. Moreover, the General Council is to be given the opportunity to submit observations on ECB opinions,<sup>660</sup> which is in line with the fact that non-participating Member States, too, are under the obligation to consult the ECB. Also, the Governing Council "may consult the Supervisory Board" for opinions related to prudential supervision.<sup>661</sup>

Finally, the ECB has adopted two Guides to its consultation by national authorities: one in 2005, and the most recent one in 2015. The Guide serves to "inform and provide assistance to national authorities about the obligation to consult the ECB".<sup>662</sup> To this end, it establishes that the 'consulting authority' is, in principle, the authority that initiates the legislative procedure, that is the responsible ministry in most cases. However, where the initiative lies with a member of parliament, it is for it to consult the ECB, and NCBs or other national authorities may be called to consult the ECB too.<sup>663</sup> The Guide additionally specifies that the "draft legislative provisions [...]" refers to provisions, which once they become legally binding and of general applicability in the whole (or a geographically distinct territory) of the Member State concerned, lay down rules which will be applicable 'in an indefinite number of cases and are addressed to

---

<sup>657</sup> For example, Opinion of the European Central Bank of 16 July 2010 on the transfer of prudential supervision tasks to the Austrian Financial Market Authority (CON/2010/57).

<sup>658</sup> Council decision of 29 June 1998 on the consultation of the European Central Bank by national authorities regarding draft legislative provisions (98/415/EC), Article 4.

<sup>659</sup> Decision of the European Central Bank of 19 February 2004 adopting the Rules of Procedure of the European Central Bank (ECB/2004/2) (ECB Rules of Procedure), Article 17(5).

<sup>660</sup> Article 12(1) ESCB Statute.

<sup>661</sup> Article 17(5) ESCB Statute.

<sup>662</sup> Yves Mersch, 'Foreword' in European Central Bank, *Guide to consultation of the European Central Bank by national authorities regarding draft legislative provisions*, 2015, p. 3.

<sup>663</sup> European Central Bank, *Guide to consultation of the European Central Bank by national authorities regarding draft legislative provisions*, 2015, pp. 8-9.

an indefinite number' of persons".<sup>664</sup> Hence, not only law but also decree-laws or secondary legislation that regard a subject matter that "is closely related to the ECB's tasks [... and whose] impact on areas within the ECB's areas of competence is different from that resulting from the primary legislation itself"<sup>665</sup> are covered by this obligation.

When amendments are made at a later stage, the amended draft piece of legislation should be submitted to the ECB if it has not yet adopted its opinion. Even if it has already adopted its opinion, the ECB should be consulted, unless the amendments proposed serve the purpose of introducing changes made in reaction to the ECB's opinion.

When submitting a draft legislative text to the ECB, national authorities are encouraged to indicate to the ECB the provisions on which its opinion is particularly sought.<sup>666</sup> They are also invited to include a short explanatory memorandum detailing "the subject matter and the main objectives pursued; the stage reached in the national legislative process; and the name and details of the contact persons available to clarify any questions about the draft legislative provisions which may arise during the ECB's drafting of its opinion".<sup>667</sup> The draft legislative text may be submitted in any of the official languages of the EU, but the ECB welcomes an English translation in cases of urgency.<sup>668</sup>

The Guide further lays out the internal procedure followed in view of adopting ECB opinions. They are drafted by a panel composed of experts from the business areas relevant to the topic of consultation.<sup>669</sup> The draft opinion is submitted to the members of the Governing Council and of the General Council for their comments and observations, respectively. The ECB prepares a consolidated version based on the input received, and a second written procedure follows during which comments or observations only regard the new amendments.<sup>670</sup>

## 1.2 Purpose and value of ECB opinions

In accordance to Article 288 TFEU,<sup>671</sup> ECB opinions are not legally binding; they merely provide national authorities with the ECB's stance on the affected matter. Therefore, "this obligation [to consult the ECB] must not prejudice the responsibility of these authorities for the matters which are the subject of such provision".<sup>672</sup>

---

<sup>664</sup> *ibid.*, p. 10.

<sup>665</sup> European Central Bank, *Guide to consultation of the European Central Bank by national authorities regarding draft legislative provisions*, 2015, p. 10.

<sup>666</sup> *ibid.*, p. 20.

<sup>667</sup> *ibid.*

<sup>668</sup> *ibid.*, p. 21.

<sup>669</sup> *ibid.*, p. 23.

<sup>670</sup> *ibid.*

<sup>671</sup> "Recommendations and opinions shall have no binding force".

<sup>672</sup> Council Decision of 29 June 1998 on the consultation of the European Central Bank by national authorities regarding draft legislative provisions (98/415/EC) (OJ L 189, 3.7.1998, p. 42), Recital 2.



This notwithstanding, the ECB's advisory function may contribute to "the harmonisation of Member States' legislation within the ECB's field of competence", hence why the ECB "[has] encourage[d] greater use of the consultation procedure" in the past.<sup>673</sup> ECB opinions also contribute to ensure consistency across Member States policies.<sup>674</sup>

As regards the function, which these opinions are called to play, the Court's reasoning in the *OLAF* judgement, which regarded the ECB's advisory opinions on EU draft pieces of legislation, may be applied to national pieces of legislation as well. Indeed, the Court found that the ECB is to be consulted "essentially to ensure that the legislature adopts the act only when the body [the ECB] has been heard, which, by virtue of the specific functions that it exercises in the Community framework in the area concerned and by virtue of the high degree of expertise that it enjoys, is particularly well placed to play a useful role in the legislative process envisaged".<sup>675</sup> Hence, the ECB merely intervenes as an expert. Its opinion cannot be viewed as binding on the authority to which it is addressed. In this sense, the General Court's interpretation in the *Steinhoff* case appears somewhat surprising as it seems to imply that, in its advisory function too, the ECB is bound by Article 51 EU Charter of Fundamental Rights, that is by its duty to "respect the rights, observe the principles and promote the application of the Charter".<sup>676</sup> This interpretation is in contradiction with the essence of the ECB's advisory role, which is limited to the provision of an expert opinion and does not extend to a full control of legality with the EU legal order generally by the ECB.<sup>677</sup> Also, because of the nature of the ECB's function, it alone should continue to adopt the necessary opinions: no implication of other (EU) institutions is necessary nor desirable. This is all the more so as the ECB is already able to draw expertise from all the NCBs. Considering the fact that ECB opinions are adopted by the Governing Council, all Governors (and their NCBs) are involved in the drafting procedure as further detailed below. This implies that this procedure amounts to a peer review process among (E) and (N)CBs as opposed to it being solely an occasion for the supranational ECB to express its opinion. This interestingly confirms the nature of NCBs as Europeanised national institutions. It also highlights the difficult position they are in since they are generally not the national institution which should consult the ECB, yet may become aware of cases in which the ECB should be consulted. However, it may be difficult for them to bypass the responsible authority by directly referring the draft legislative text to the ECB. Also, the fact that it is the NCBs and not the responsible authorities, which are involved in most cases implies that national

---

<sup>673</sup> Yves Mersch, 'Foreword' in European Central Bank, *Guide to consultation of the European Central Bank by national authorities regarding draft legislative provisions*, 2015, p. 3.

<sup>674</sup> The ECB itself noted this positive contribution during the Financial crisis for instance. European Central Bank, *Guide to consultation of the European Central Bank by national authorities regarding draft legislative provisions*, 2015, p. 4.

<sup>675</sup> Case C-11/00, *Commission of the European Communities v European Central Bank*, ECLI:EU:C:2003:395, para. 110.

<sup>676</sup> Case T-107/17, *Frank Steinhoff and Others v European Central Bank*, ECLI:EU:T:2019:353, paras. 86 ff. This argument was not examined by the Court of Justice in the appeal procedure lodged before it (Case C-571/19 P, *EMB Consulting SE and Others v European Central Bank*, ECLI:EU:C:2020:208).

<sup>677</sup> The situation is of course different when EU institutions actively take part in the making of a decision, even when they act outside of the EU legal order. See on this point: M. Markakis, *Accountability in the Economic and Monetary Union. Foundations, Policy and Governance*, Oxford University Press, 2020, pp. 234 ff.

involvement is only indirect, and thus that the circulation of information (and expert knowledge) is not straightforward.

Before turning to the other functions, which the ECB opinions fulfil, a remark concerning the value of ECB opinions is in order. They are certainly non-binding, but may still be perceived as having authority by its addressee. In fact, as illustrated by the *Banka Slovenije* case,<sup>678</sup> the ECB's interpretation may be overturned by the Court of Justice. This is only logical, and generally holds true of opinions adopted by EU institutions. However, such changes may have far-reaching consequences, as the ECB and NCBs alike may have been acting for long based on the interpretation they have developed in the framework of the Governing Council.

In the ECB's own words, its "[expert] advice is intended to ensure that the national legal framework: (a) contributes to the achievement of the objectives of the EC and/or the European System of Central Banks (ESCB); (b) is compatible with the legal framework of the Eurosystem/ESCB and of the ECB; and (c) is in line with the Eurosystem/ESCB and ECB policies".<sup>679</sup>

Beyond this, the ECB's advisory function also contributes to "forestall problems with potentially incompatible or inconsistent national legislation",<sup>680</sup> hence why the consultation should take place sufficiently early in the legislative procedure at the national level. The ECB points out that this procedure promotes the sharing of information and expertise thereby improving the quality of national legislation, whilst also allowing it to remain "informed about legislative developments in the Member States within the ECB's fields of competence".<sup>681</sup> This, in turn, is helpful for it to design its position in other EU or international fora, and contributes to its communication towards the public. ECB opinions may also inform national and EU judges in the framework of later judicial proceedings.

Finally, ECB opinions play a crucial role before Member States adopt the common currency, as is recalled in the Convergence reports it regularly adopts.<sup>682</sup>

## 2 The practice of ECB opinions on national draft legislative acts to date

As will be illustrated in this section, the practice of ECB opinions has varied between 1999 and 2023. These variations regard both the number of opinions (section 2.1), as well as the policy areas they have concerned (section 2.2). Also, differences among Member States exist as well (section 2.3).

---

<sup>678</sup> Case C-45/21, *Banka Slovenije*, ECLI:EU:C:2022:670. See on this case T. Martinelli, "The liability of National Central Banks acting as resolution authorities, financial independence, and the prohibition of monetary financing: *Banka Slovenije*", *Common Market Law Review*, forthcoming.

<sup>679</sup> European Central Bank, *Guide to consultation of the European Central Bank by national authorities regarding draft legislative provisions*, 2015, p. 6.

<sup>680</sup> *ibid.*

<sup>681</sup> *ibid.*

<sup>682</sup> See for instance: European Central Bank, *Convergence Report 2022*, Frankfurt am Main, p. 20, available at <https://www.ecb.europa.eu/pub/pdf/conrep/ecb.cr202206-e0fe4e1874.en.pdf>.

## 2.1 Variation in the number of ECB opinions over time

**Chart 1**

Non-binding ECB legal acts in force (1998 – October 2023)<sup>683</sup>

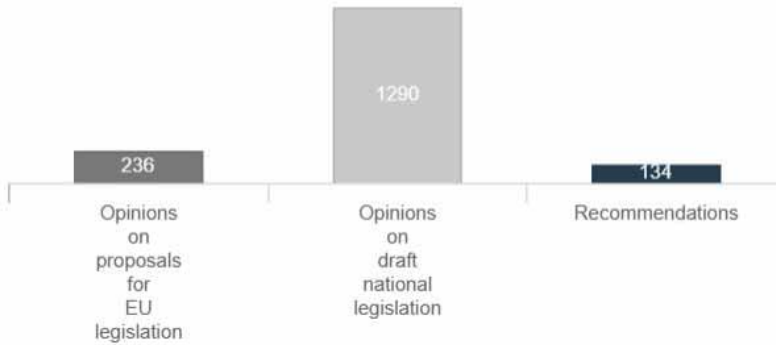

As Chart 1 shows, ECB opinions on national draft pieces of legislation have been much more numerous than those regarding EU pieces of legislation. This is only logical considering the (growing) number of Member States that are part of the EU.

**Chart 2**

ECB opinions per year<sup>684</sup>

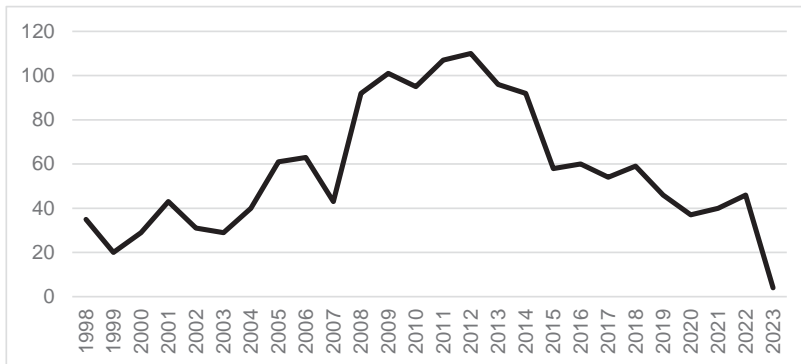

Chart 2 illustrates that the number of opinions adopted by the ECB has significantly varied over time. Several factors may account for these fluctuations: on the one hand, the number of EU Member States grew from 15 to 28 between 1998 and 2007.

<sup>683</sup> Data extracted from Eur-Lex Visual navigation - EUR-Lex (europa.eu) (30.10.2023)

<sup>684</sup> Own compilation based on Eur-Lex data (1998 – March 2023).

On the other hand, as already noted, the Great Financial Crisis demanded the adoption of numerous pieces of legislation in the areas of competence of the ECB, thus explaining the peak in the number of opinions observable between 2008 and 2013.

## 2.2 Variations across policy areas

Differences not only exist as regards the number of opinions adopted every year. They also concern variations across policy areas.

### Chart 3

ECB opinions by topic<sup>685</sup>

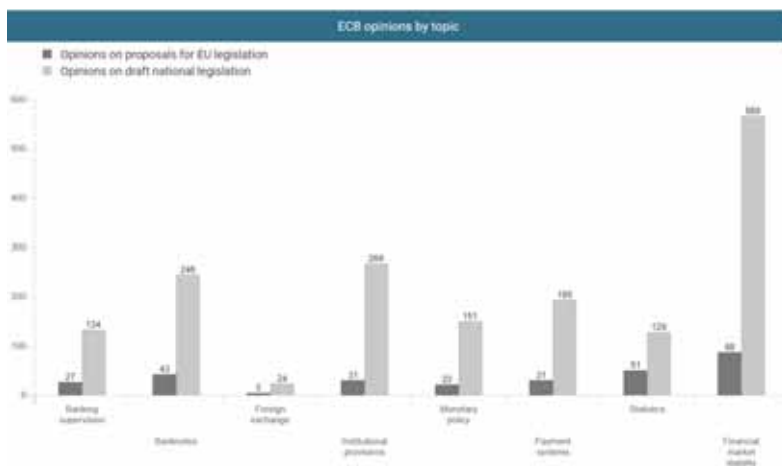

Chart 3 shows that the number of opinions adopted by the ECB varies significantly depending on the policy area with the largest number of opinions regarding financial market stability, followed by institutional provisions and banknotes. This is rather unsurprising considering the amount of legislation that had to be adopted in response to the Great Financial Crisis. It could also be expected that numerous opinions had to be adopted on institutional provisions considering the important role played by NCBs in the functioning of the Eurosystem. By contrast, monetary policy opinions only concern non-euro area Member States since the ECB is in charge of this matter for euro area Member States, hence why the number of opinions on this subject matter are rather limited. Only relatively few opinions have been adopted by the ECB on banking supervision matters, which may probably be explained by the fact that the ECB did not used to be in charge of banking supervision (although it could still be consulted on this matter prior to the establishment of the Banking Union).

<sup>685</sup> Data extracted from Eur-Lex Visual navigation - EUR-Lex (europa.eu) (30.10.2023).

## 2.3 Differences across Member States

Not only do the number of ECB opinions vary over time or policy areas. Differences may also be observed across Member States.

**Chart 4**

ECB opinions per Member State<sup>686</sup>

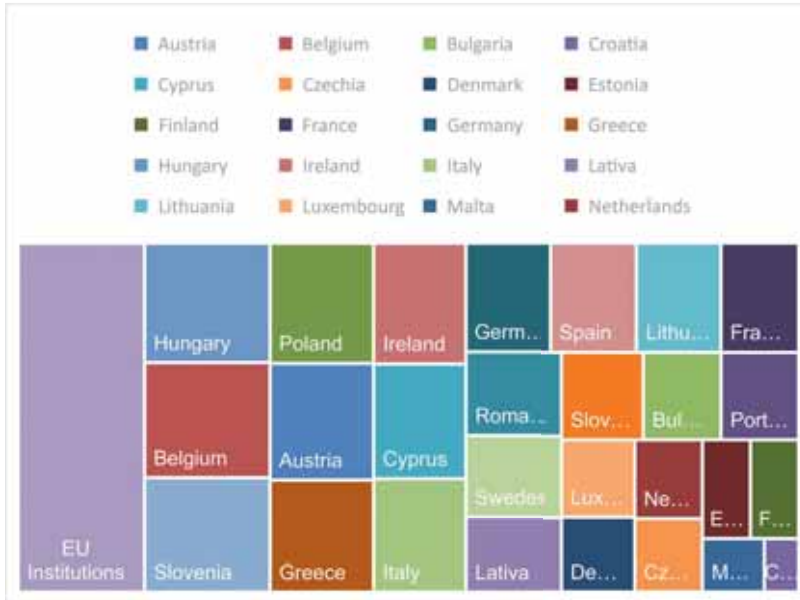

<sup>686</sup> Own compilation based on Eur-Lex data (1998 – March 2023).

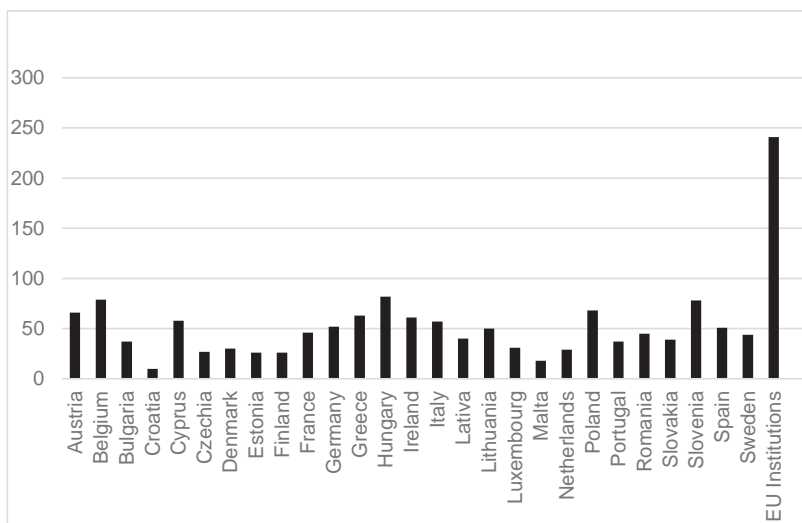
**Chart 5**ECB opinions per Member State<sup>687</sup>

As Charts 4 and 5 illustrate, important variations exist among Member States. Perhaps somewhat unexpectedly, there is not necessarily any correlation between shorter EU membership (i.e. for the Member States that joined in 2004 and 2007) and more reduced number of opinions. Other factors, such as the fact of having been a ‘crisis Member State’ during the Great Financial Crisis appear to be a much stronger determinant, as shown for instance by the Cypriot, the Greek and the Portuguese cases. Other States including Hungary and Poland have performed a significant number of reforms over the past years, which explains the relatively high number of ECB opinions adopted on their draft pieces of legislation. Other cases, such as the Austrian, the Belgian and the Slovenian ones, are slightly more difficult to explain. However, it could be that varying institutional cultures play a role too, where some national institutions may be more compliant (or ‘zealous’) than others, or where members of parliaments more often make legislative proposals, which even if they are not adopted eventually, are submitted to the ECB for its opinion.

It is generally somewhat uneasy to determine the extent to which Member States comply with their obligation to consult the ECB on their draft legislative proposals. Indeed, opinions are not consistently labelled as ‘own initiative opinions’ (vs ‘opinions’) on the Eur-Lex portal (where they are now all published, after having been previously made available via the ECB’s website after 2005), such that only the individual analysis of the opinions adopted by the ECB would allow to determine how many of them have been adopted by the ECB on its own initiative, that is presumably after a Member State had failed to consult it (as it should). Perhaps the ECB’s choice to use its annual report to ‘name and shame’ (severely) incompliant Member States by including a list of “clear and important cases of non-consultation” is more efficient as indeed some of the failures to consult the ECB, which give rise to ‘own initiative

<sup>687</sup> Own compilation based on Eur-Lex data (1998 – March 2023).

opinions' are truly genuine failures to identify pieces of legislation, which affect the ECB's areas of competences. In its annual reports, the ECB focuses on targeted serious breaches, which are not very numerous: four in 2022, three in 2021, four in 2020, eight in 2019, whereby seven were considered to be 'clear and important'.<sup>688</sup> However, when one considers that, for example, the ECB adopted 32 opinions in total in 2022, four appears to be still a relatively high number. Also, between 2019 and 2022, two Member States (Italy and Lithuania) stand out for having committed a 'clear and important' breach of their obligation during three of these four years. Variations have existed over time though, as for instance it is Cyprus, Greece, Hungary, Ireland and Italy that were considered to be clearly and repetitively fail to consult the ECB in 2015.<sup>689</sup>

Non-consultation letters are a further indicator of Member States' compliance of their obligations to consult the ECB. The Eur-Lex portal contains 34 such letters, which were adopted between 2014 and 2022. These 34 letters were addressed to 16 Member States. Whereas half of them (Bulgaria, Croatia, Finland, Lithuania, Luxembourg, Poland, Slovakia, Sweden) only received one letter, the other half received between two and four letters over that time period, with Italy and Slovenia having received the most (four each).

As already noted, these cases of non-compliance could derive from genuine failures to identify that a measure falls within the realm of the ECB's competences. However, where cases are recurrent, they could also be due to the political decision not to consult the ECB in order to avoid having to follow (or at least take account of) its opinion. Alternatively, they could also constitute signs of administrative dysfunction in specific Member States.

In any event, the ECB's actions to try to provide remedy to the Member States' failure to comply with their obligation to consult it – be it by publishing non-compliant letters, be it by 'naming and shaming' in its annual reports – are welcome. They may serve as preventive or alternative measure to judicial procedures. Indeed, considering the fact that Member States have a duty to consult the ECB, the European Commission could (on its own initiative or upon invitation by the ECB) decide to launch an infringement procedure against a Member State that has failed to respect its obligation. Where it is an NCB that has failed to consult the ECB, the ECB could, too, bring it to Court.<sup>690</sup> This is a nuclear option though, and one that the European Commission and the ECB will likely only resort to in very serious cases (all the more so as the Commission has been launching always fewer infringement procedures in recent years<sup>691</sup>). Hence why the consultation letters (and their publication on Eur-Lex) as well as the 'naming and shaming' of significant breaches in the ECB's annual reports should be viewed positively.

---

<sup>688</sup> See the ECB Annual Reports available on the ECB's website at <https://www.ecb.europa.eu/pub/annual/html/index.en.html>.

<sup>689</sup> European Central Bank, *Annual Report 2015*, Frankfurt am Main, p. 86.

<sup>690</sup> Article 35(6) ESCB Statute.

<sup>691</sup> See on this phenomenon: Daniel R. Kelleman and Tommaso Pavone, "Where Have the Guardians Gone? Law Enforcement and the Politics of Supranational Forbearance in the European Union", *World Politics*, 75(4), 2023, pp. 779-825.

### 3 Conclusion

The previous sections have served to highlight the legal framework that governs the adoption of ECB opinions on national pieces of legislation and to describe their practice to date. This concluding section shall be used to present an assessment thereof.

Indeed, so far, the analysis presented has focused on the adoption of ECB opinions (or the absence thereof), but it has neglected the question of the impact of these opinions. As highlighted, ECB opinions are in no way binding on their addressees, and it is thus particularly uneasy to try and determine the extent to which they shape the piece of legislation finally adopted (if it is adopted that is, since not all the pieces of legislation on which the ECB adopts an opinion will finally turn into a piece of legislation). In fact, even if one examines the piece of legislation as originally proposed, the ECB's opinion and the text finally adopted, it is still difficult to trace back the ECB's influence: some amendments may be made during the legislative process that align with the ECB's opinion but are not necessarily related to or deriving from it. Only where express reference is made to the ECB's opinion can one be sure that it has been determinant in shaping a given amendment, and this would demand the analysis of the procedure under which each and every proposal has undergone. Interviews with the institutional actors involved could also prove helpful, but again they would need to be conducted individually.

In spite of this impossibility to draw general conclusions, it may reasonably be posited that ECB opinions matter and are taken into consideration by national authorities, although differences may exist across Member States and across policy areas.

The ECB itself noted in 2015 that “[t]his system has proved to be effective and national legislators have generally agreed to amend or even withdraw draft legislative provisions rather than adopt legislation that conflicts with the ECB's position”.<sup>692</sup> Hence, it seemed to be quite satisfied with the procedure in place. It remains, however, that a few exceptions to this good practice may definitely be observed as some opinions recurrently address the same issues. This has, for example, been the case with Hungary and the opinions regarding the law governing its Central Bank.

Furthermore, it may also be assumed that not all Member States authorities perceive ECB opinions in the same manner, or even have the same knowledge of them. Ministries and NCBs might be more familiar with them and more conscious of the need to request them than individual member of parliaments for example. Additionally, not all ECB opinions may be perceived as equally important: it is likely that those regarding areas that are closest to the ECB's area of competence and where it thus has significant expertise may be viewed as more important to follow than those that only marginally affect it. Opinions adopted as part of a Member State's convergence path prior to adopting the euro are certainly an example of 'more binding opinions' as they condition a Member State's ability to start using the common currency. Where the ECB

---

<sup>692</sup> European Central Bank, *Guide to consultation of the European Central Bank by national authorities regarding draft legislative provisions*, 2015, p. 7.



itself may bring an NCB to Court, it is likely that its opinions are also perceived as 'more binding'.

In sum, the ECB's advisory function appears to largely function satisfactorily, despite the large amount of resources it demands. This procedure brings numerous benefits, both for the ECB and the requesting authority, but also for the other NCBs, which are duly involved and called to provide their input when the opinion is being drafted while also being usefully informed of developments in other Member States. However, as has been shown in this contribution, little is known about the actual impact of ECB opinions, and future research should seek to clarify this aspect by performing a qualitative analysis of a (selection of) national pieces of legislation.

# The ECB advisory role: opinions as soft law in a shared normative space

David Ramos Muñoz\*

## 1 Introduction

Like Oscar Wilde put it, “I always pass on good advice. It is the only thing to do with it. It is never of any use to oneself.”<sup>693</sup> This quote captures two basic, and important ideas: advice is something everyone likes to ‘pass’, ‘share’, ‘give’, ‘offer’, ‘provide’, but seldom ‘retain’, ‘keep’, or ‘own’. It is a noun linked to motion and social interaction, less to ownership or introspection. Since this contribution follows Diane Fromage’s enlightening analysis of ECB opinions, their numbers, requesting parties, substance, etc.<sup>694</sup> and precedes judge Sampoll’s excellent approach to ECB opinions before EU Courts,<sup>695</sup> its purpose is to sketch a theory that can help explain what is the role of ECB opinions, and make sense of the way courts look at them.

This requires combining the legal basis for such opinions with the actual reality of where and when those opinions are issued, and how they are scrutinised. This contribution classifies ECB opinions as part of ‘soft law’. A broader understanding of soft law that encompasses instruments that provide explicit guidance, as well as those that, like opinions, merely provide advice, helps to gain perspective on the norm emergence processes in the crowded landscape of EU policymaking, and to gain precision in their forms of accountability, especially legal or judicial accountability. At the same time, it helps to see soft law in a positive light, not as a way to circumvent procedures, but to deal with complexity in the presence of dispersed information, overlapping competences and decentralised sources of authority. This contribution discusses, first, the legal basis for ECB opinions, or the ECB advisory role in the Treaties (section 2). Then, it provides a theoretical basis for the role and functions of soft law in the norm emergence process, and the relevance, in this context, of the idea of ‘shared normative space’ (section 3). On this basis, it briefly explains how the ECB’s shared normative space has evolved, and the challenges this presents for the ECB’s advisory role, and its implications for its (legal) scrutiny (section 4). Section 5 is devoted to conclusive remarks.

---

\* David Ramos Muñoz is Professor at Universidad Carlos III de Madrid.

<sup>693</sup> Oscar Wilde ‘An Ideal Husband’ Act 1.

<sup>694</sup> See Diane Fromage, ‘ECB opinions on national legislative proposals: Practice to date and Outlook’.

<sup>695</sup> Miguel Sampol Pucurull, ‘To consult or not consult: the question on the legal consequences’.

## 2 The ECB's advisory role: legal basis for ECB opinions<sup>695</sup>

To understand the ECB's advisory role, it is useful to refer to the 'text' that defines such role, the 'context' of the provisions, and the 'finality' of said advisory function.

Starting with the text, Article 127 (4) TFEU states that:

"The European Central Bank shall be consulted:

- on any proposed Union act in its fields of competence,
- by national authorities regarding any draft legislative provision in its fields of competence, but within the limits and under the conditions set out by the Council in accordance with the procedure laid down in Article 129(4).

The European Central Bank may submit opinions to the appropriate EU institutions, bodies, offices or agencies or to national authorities on matters in its fields of competence".

Article 282 (5) TFEU, for its part, states that:

"Within the areas falling within its responsibilities, the European Central Bank shall be consulted on all proposed Union acts, and all proposals for regulation at national level, and may give an opinion".

Thus, an initial look at these two constitutional provisions shows that they share the same spirit, but not the same language, with Article 127 (4) referring to 'fields of competence' and Article 282 (5) to 'areas within its responsibilities'. As to the subject-matter of the consultation, both Article 127 (4) and 292 (5) refer to 'proposed Union acts', but for national provisions Article 127 (4) refers to 'draft legislative provisions' and Article 282 (5) to 'proposals for regulation'. All this requires clarification.

The Council, in accordance with Article 127 (4) TFEU, issued a decision, which regulates the ECB consultation,<sup>696</sup> and which states that:

"draft legislative provisions' shall mean any such provisions which, once they become legally binding and of general applicability in the territory of a Member State, lay down rules for an indefinite number of cases and are addressed to an indefinite number of natural or legal persons."

While at the same time, clarifying that:

"Draft legislative provisions shall not include draft provisions the exclusive purpose of which is the transposition of Community directives into the law of Member States."

While this phrasing clarifies which texts must be subjected to the advice of the ECB, it does not say what are the ECB's 'fields of competence', or 'areas falling within its

---

<sup>695</sup> The Treaty basis for the ECB's advisory role is well established, but the language creates interpretative uncertainties, which are aggravated by an outdated Council Decision. The Court's approach in *OLAF* offers a more promising approach.

<sup>696</sup> Council Decision of 29 June 1998 on the consultation of the European Central Bank by national authorities regarding draft legislative provisions (OJ L 189, 3.7.1998, p. 42).

responsibilities'. For that, we also need the **context**. The more eloquent way to illustrate this context is by comparing Article 127 (2) and (5) TFEU, with Article 2 of the Council Decision in the accompanying table:

Types of competences/tasks	Article 127 (2) and (5) TFEU	Article 2 Council decision
<b>Central banking</b>	(2) The basic tasks to be carried out through the ESCB shall be: — to define and implement the monetary policy of the Union, — to conduct foreign-exchange operations consistent with the provisions of Article 219, — to hold and manage the official foreign reserves of the Member States, — to promote the smooth operation of payment systems.	The authorities of the Member States shall consult the ECB on any draft legislative provision within its field of competence pursuant to the Treaty and in particular on: . currency matters, . means of payment, . national central banks, . the collection, compilation and distribution of monetary, financial, banking, payment systems and balance of payments statistics, . payment and settlement systems,
<b>Financial institutions/supervision</b>	(5) The ESCB shall contribute to the smooth conduct of policies pursued by the competent authorities relating to the prudential supervision of credit institutions and the stability of the financial system.	. rules applicable to financial institutions insofar as they materially influence the stability of financial institutions and markets.

The table omits on purpose Article 127 (6) TFEU, which enables the Council, by means of a regulation, using a special procedure involving unanimity, to “confer specific tasks upon the European Central Bank concerning policies relating to the prudential supervision of credit institutions and other financial institutions with the exception of insurance undertakings”, which, it is well known, is the basis of the SSM Regulation,<sup>697</sup> vesting the ECB with the primary responsibility for supervision of credit institutions in the euro area. This omission is to stress that Article 2 of the Council Decision seems frozen in a pre-SSM era, where the ECB’s competence regarding financial institutions and financial stability was relatively modest.

The corresponding paragraph of Article 2 of the Council Decision seems inspired on the logic of Article 127 (5), and the Council has not taken the opportunity to use the adoption of the SSM Regulation, approved by the Council itself, to update Article 2. This is problematic because, apart from Article 127 (5) TFEU suggesting a relatively superficial role for the ECB on supervision and stability, the Protocol itself in Article 25 refers to the possibility of an advisory role by the ECB on matters of financial supervision, specifying however that “the ECB may offer advice”, rather than stating that the institutions must ask for its advice.<sup>698</sup> Furthermore, although the Council decision, which reinforces this diminished advisory role for the ECB on matters of financial stability, regulation and supervision, applies to advice-seeking by Member States, the objective scope of the ECB’s advisory role is the same for advice to national and EU acts: in both cases, the TFEU requires consulting the ECB only in its “fields of

<sup>697</sup> Council Regulation (EU) No 1024/2013 of 15 October 2013 conferring specific tasks on the European Central Bank concerning policies relating to the prudential supervision of credit institutions (OJ L 287, 29.10.2013, p. 63) (SSM Regulation).

<sup>698</sup> Article 25 (1) of the ESCB/ECB Protocol states that: “The ECB may offer advice to and be consulted by the Council, the Commission and the competent authorities of the Member States on the scope and implementation of Union legislation relating to the prudential supervision of credit institutions and to the stability of the financial system”. Para. (2) of the same provision replicates the message of Article 127 (6) TFEU, reinforcing the idea of a secondary role.

competence” or “areas within its responsibilities”. If these ‘competences’ or ‘responsibilities’ were to be interpreted strictly, they could be interpreted strictly for both consultations by Member States and EU acts.

Still, although Article 2 seems partly inspired by an earlier status quo, the question is whether the provision is inevitably anchored in the past, or can be interpreted in light of the new circumstances. To answer this question, in addition to the text and context, it is also important to look at the **finality**, or purpose of the ECB’s advisory role. The main authoritative statement to this effect can be found in the *OLAF* case, where the ECB opposed the creation of an anti-fraud office that could have competences over the ECB itself, opposing, among other arguments, that the ECB had not been consulted, in accordance with Article 127 (4) TFEU. The Court, following the AG Opinion, rejected this point, holding, in two succinct, but insightful paragraphs, that:

“(110) In that regard, the Court observes that Article 105(4) EC is **placed in Chapter 2, devoted to monetary policy**, of Title VII of Part Three of the EC Treaty and that the obligation laid down in that provision to consult the ECB on any proposed act in its field of competence **is intended**, as the Advocate General points out at paragraph 140 of his Opinion, essentially to ensure that the legislature adopts the act only when the body has been heard, which, **by virtue of the specific functions that it exercises in the Community framework in the area concerned** and by virtue of **the high degree of expertise that it enjoys**, is particularly **well placed to play a useful role** in the legislative process envisaged.

(111) That is not the case as regards the prevention of fraud detrimental to the financial interests of the Community, **an area in which the ECB has not been assigned any specific tasks**. Furthermore, the fact that Regulation No 1073/1999 may affect the ECB’s internal organisation does not mean that the ECB should be treated differently from the other institutions, bodies, offices and agencies established by the Treaties”.<sup>699</sup>

Still, although insightful, the Court’s view could still be equivocal about the rationale for future cases. One possible reading of these two paragraphs is ‘constitutional’: the Court would be trying to ensure that the ECB’s ‘core’ competence on monetary policy (with perhaps some adjacent elements) is not encroached upon by adopting legislation in this field without consulting the ECB. Under a second, ‘functional’ reading, the Court would be trying to ensure that the ECB is allowed to execute the functions and tasks that it actually performs without frictions and inconsistencies created by legislation adopted without consulting the ECB. Under a third, ‘informational’ reading, the Court would be trying to ensure that all the relevant information and expertise that the ECB can muster and contribute is actually incorporated into the process.

The three lines of reasoning are used by the Court to give a clear response: there was no legal obligation to consult the ECB in that case. However, for future cases the solution may be less clear; indeed, it is not the same to ask whether the issue is within monetary policy or related to it, whether the issue falls within a task performed in practice by the ECB, or whether it is an issue where the ECB has expertise. It is here proposed that the ‘functional’ reading is preferable. The reference to ‘monetary policy’

---

<sup>699</sup> Judgment of 10 July 2003, *Commission v ECB*, C-11/00, ECLI:EU:C:2003:395 (OLAF).

in the text seems to be introductory, and the actual argument is about the ECB's 'specific functions'. The open-ended reference to the fact that 'the ECB has not been assigned any specific tasks' also suggests that the approach is evolutionary and modular: if the ECB is assigned new tasks in a specific field, this should be complemented with a duty to consult it in that field. An 'informational' approach would give rise to too much uncertainty, given that the ECB is a large institution, which can provide expertise on many fields. Unless the mandatory duty to consult is linked to the ECB's expertise based on functions actually performed pursuant to the Treaty or secondary legislation, the provision would be legally defective, as it would also allow the ECB - by increasing the scope of the duty - to consult by way of expanding its fields of expertise, e.g., hiring personnel on related areas.

### 3 A conceptual background: soft law's role in a shared normative space<sup>σ</sup>

ECB opinions may not fall squarely under traditional conceptions of 'soft law', which may focus more on 'guidance' documents by financial authorities, or agreements, such as Memoranda of Understanding (MoUs) between them. However, instead of a convention about what soft law is, and is not, it would be more useful to discuss what soft law is for, and, only in light of this, determine whether opinions (from the ECB or other bodies) are part of it. Some authors highlight soft law as a mechanism of inter-institutional cooperation,<sup>700</sup> to build legislation by incremental steps.<sup>701</sup> Others focus on its 'exhortative',<sup>702</sup> or 'influencing' role.<sup>703</sup> Yet, everyone seems to agree on its 'atypical', and non-binding nature.<sup>704</sup> In principle, this does not (nor should) exclude opinions. These are included by Article 288 TFEU among the EU's 'legal acts', and singled out, together with 'recommendations' as 'non-binding'. Furthermore, opinions (including ECB opinions) can be quite influential, and in some specific contexts, such as the monitoring of EU financial assistance programmes, subject to conditionality. Also, even if the opinion itself is not generally binding, the fact of asking the ECB (and other institutions or bodies) for it is a mandatory requirement for producing legislation.

If ECB opinions are analysed as part of the broader phenomenon of EU soft law, the question is how to characterise the latter. If everyone agrees that soft law is atypical,

<sup>σ</sup> ECB opinions are considered part of 'soft law' under a broader understanding of the term, which would encompass the instruments that shape norm emergence under a 'social norms' dynamics. Soft law can be a source of information, coordination and authority, and be integrated by acts where such elements are present with varying intensity. This intensity depends on the role that the concrete soft law instrument occupies in the process, which, in turn, depends on the configuration of the 'shared normative space' between norm-producing institutions.

<sup>700</sup> OECD 'Soft law'. <https://www.oecd.org/gov/regulatory-policy/irc10.htm#:~:text=Definition,guidelines%2C%20roadmaps%2C%20peer%20reviews>.

<sup>701</sup> Timothy Meyer (2008), 'Soft Law as Delegation', *Fordham International Law Journal*, vol. 32(3), pp. 888-942.

<sup>702</sup> Heikki Marjosola, Marloes van Rijsbergen, Miroslava Scholten (2022), 'How to exhort and to persuade with(out legal) force: Challenging soft law after FBF', *Common Market Law Review* 59(5), pp. 1523-1542.

<sup>703</sup> Jacob Gersen and Eric A. Posner (2008), 'Soft Law: Lessons from Congressional Practice', *Stanford Law Review* 61, pp. 573-628.

<sup>704</sup> See, e.g., Giulia Bertezzo (2009), 'The European Union Facing the Global Arena: Standard-Setting Bodies and Financial Regulation', 34 *European Law Review* 257, pp. 265-268; Menelaos Markakis and Paul Dermine (2018), 'Bailouts, the legal status of Memoranda of Understanding, and the scope of application of the EU Charter: Florescu', *Common Market Law Review*, 55.

as it does not follow conventional law-making processes, influential, and yet 'not binding', it is worth analysing what is the relevance of these elements. To do that, it is useful to focus on what can characterise a norm as a 'legal norm', and since legal positivism largely developed to answer this question, it provides a useful starting point. Hart's view of positivism posits that the existence and content of law does not depend on its 'merit' (i.e., morality), but on social facts, such as how laws may be changed (rules of change), who must have the authority to decide disputes ('rules of adjudication'), what they must treat as binding reasons for decision (rule of recognition).<sup>705</sup> Of these 'secondary rules', the 'rule of recognition' is the most important for our purposes, as it helps draw a (stark) distinction between rules that are law and those that are not.

The question is whether this account of the normative process leaves something relevant out, and what this 'something' may be. Alternative views of the normative process focus instead on 'social norms', and how they are produced. Bicchieri, in particular, posits that social norms result from conditional preferences for conforming to a relevant behavioural rule. Such preferences are conditional on two kinds of beliefs: (i) empirical expectations: first-order beliefs that a certain behaviour will be followed; (ii) normative expectations: second-order beliefs that a certain behaviour ought to be followed.<sup>706</sup> Social norms are not legal norms, but they are definitely relevant. The question is whether some elements of either view can help make sense of soft law.

In reality, Hartian positivism is 'empirical' and 'conventional'. Legal norms are the norms that officials practice, and the ones they appeal to when there is a conflict. Thus, there are the 'social norms' practiced by a very specific subset of society, which makes its normative expectations conditional on a very specific set of instructions, based on the rule of recognition. The fact that norm-producing institutions and bodies (including legislators, or the European Commission, but also regulatory and supervisory bodies, including the ECB) engage in the 'formal' normative process by, for instance, proposing or approving legal norms when they are required or authorised to do so, does not exclude their participation in the process of construing social norms by trying to affect the behavioural and normative expectations of other norm-producing institutions and bodies, but also of the general public, in a way that can act as a prelude to the adoption of legal norms.

This background, based on the broader idea of social norms, is useful for two reasons. First, rather than a stark distinction between norms of 'public officials' and the norms of the public, it allows 'degrees of normativity', depending on the 'subject' and the 'reasons'. Second, it helps to understand soft law without invariably casting a negative light over it. Although soft law can lead to opacity and the circumvention of formal procedures, it is wrong to characterise soft law in light of these elements (if so, the best would be to abolish it). If the formation of behavioural and normative expectations is a fact of life, which norm-producing institutions seek to influence, the alternative to

---

<sup>705</sup> H.L.A. Hart (1994), *The Concept of Law Oxford*, Clarendon Press.

<sup>706</sup> Cristina Bicchieri (2016), *Norms in the Wild. How to Diagnose, Measure and Change Social Norms*, Oxford University Press.

soft law is not 'law', but a process of influence-seeking that takes place underground, instead of in the open.

This norm-producing process to which soft law contributes can be broken down in different parts. Here it is proposed that soft law contributes as a source of 'information' or intelligence, 'coordination', and 'authority'.

The function of soft law as a source of information or intelligence is based on ideas that date (at least) back to Hayek and other authors, who posited that knowledge is generally dispersed.<sup>707</sup> Thus, soft law can facilitate the aggregation of information or knowledge to lead to more efficient outcomes.<sup>708</sup> The ECB itself highlights this informational dimension with regard to its opinions, as crucial to (i) prevent illegalities or incompatibilities (European System of Central Banks (ESCB)), (ii) information-sharing, expertise, (iii) improve quality of legislation, and (iv) communicate with public and markets.<sup>709</sup>

The function of soft law as a source of coordination is closely linked to its informational function.<sup>710</sup> In fact, some authors, like Gersen and Posner, explain soft law's coordination role in light of 'information-based theories', such as signalling and cheap-talk theories.<sup>711</sup> Admittedly, the mere diffusion of information helps different norm-producing bodies and the public to coordinate.

However, it is indiscriminate as to the form of coordination and the players involved in it. In my view, coordination involves information-sharing, but following a certain 'structure', which results from the law, or from the practice of norm-producing institutions. In its more basic forms, there can be '**vertical**' coordination, when an institution or body issues guidelines and recommendations that other institutions or bodies are supposed to take on board to issue binding decisions, exhorting them to act, or understand a certain legal mandate in a certain way, as well as 'horizontal' coordination, when different institutions conclude MoUs.<sup>712</sup> Then, there are forms of coordination that are harder to classify, such as joint policymaking, e.g., between the European Supervisory Authorities (ESAs) and the ECB, where the former are supposed to act as the producers of norms that the latter applies (vertical),<sup>713</sup> but in

---

<sup>707</sup> Friedrich A. Hayek (1945), 'The Use of Knowledge in Society', *The American Economic Review*, Vol. 35, No. 4, pp. 519- 530. See also, by the same author, (1989), 'The Pretence of Knowledge', *The American Economic Review*, Vol. 79, No. 6, Nobel Lectures and 1989 Survey of Members, pp. 3-7.

<sup>708</sup> Cass R. Sunstein (2013), 'The Office of Information and Regulatory Affairs (OIRA): Myths and Realities' *Harvard Law Review*, p. 1838.

<sup>709</sup> European Central Bank (2015), 'Guide to consultation of the European Central Bank by national authorities regarding draft legislative provisions', p. 7.

<sup>710</sup> Information aggregation can make collective decisions superior to individual decisions, under certain conditions (Condorcet theorem). See Jean-Antoine-Nicolas de Caritat and Marquis de Condorcet (1785), 'Essai sur l'application de l'analyse à la probabilité des décisions rendues à la pluralité des voix' *Imprimerie Royale*, available at: <https://gallica.bnf.fr/ark:/12148/bpt6k417181.image>. The 'Condorcet Theorem' has stirred much discussion about its conditions of applicability, and limitations. See, e.g., David Austen-Smith and Jeffrey S. Banks (1996), 'Information Aggregation, Rationality, and the Condorcet Jury Theorem', 90 *The American Political Science Review* 34.

<sup>711</sup> Jacob Gersen and Eric A. Posner (2008), 'Soft Law: Lessons from Congressional Practice', 61 *Stanford Law Review* 591.

<sup>712</sup> SSM Regulation, recital (33).

<sup>713</sup> SSM regulation, recital (32). See also ECB-SRB MoU, available at <https://www.srb.europa.eu/en/content/ecb-and-srb-sign-memorandum-understanding-share-confidential-data>



practice they engage in a collaborative process. ECB opinions would fall under this category, since they are not binding, nor anticipate what the final legal text will look like, but are a mandatory step of the norm-producing process, and, in certain cases, may inform how the ECB, as the ultimate norm-applying institution, understands the normative background that it will apply.

Finally, soft law's function as a source of authority requires starting from ideas of 'legal authority', as a point of reference for soft law's 'authority'. Joseph Raz's theory presents law as a directive from a legitimate authority, which provides second-order reasons for action that pre-empt other reasons against that action, and exclusionary reasons to abstain from breaching the legal directive.<sup>714</sup> Naturally, this theory leaves little room for soft law. However, authors like Marmor posit that the concept of 'authority' can be construed more broadly to encompass the idea of 'authoritative advice'.<sup>715</sup> Unlike Raz's idea of 'legal authority', authoritative advice provides first-order reasons to act. These reasons do not pre-empt other reasons that the subject can wield as a justification for not acting in accordance with the advice. Nor does it offer 'exclusionary' reasons to abstain from breach. However, authoritative advice shifts the burden to the subject of the advice to offer competing its reasons not to act.<sup>716</sup> This idea is useful to capture the possibility of different degrees of authority of soft law acts.

The previous classification shows that ECB opinions may have 'less authority' than other soft law acts, which, in turn, have less authority than legal norms, and that this is no obstacle to characterising them as 'soft law', since soft law's functions can show variability. However, the classification also shows that at least soft law's coordination and authority functions are not 'randomly variable': they depend on the specific place that the soft law act occupies in the system.

This leads to introduce the second relevant concept in this section: the 'shared normative space'. The concept is an adaptation of the idea of 'shared regulatory space' by Rossi and Freeman,<sup>717</sup> who use it to analyse the phenomenon of overlaps and fragmentation in delegation to agencies, who require them to 'share regulatory space'. According to Rossi and Freeman, explaining this phenomenon as 'redundancy' (i.e., as a legislative 'mistake') is simplistic. Legislators may have other reasons to create this shared space, including to foster inter-agency competition and information production,<sup>718</sup> to seek compromise solutions,<sup>719</sup> or to acknowledge that certain problems are complex, and require multiple inputs.<sup>720</sup> Thus, reducing 'overlaps' by concentrating tasks may be impossible, or undesirable.<sup>721</sup>

---

<sup>714</sup> Joseph Raz (2009), *The Morality of Freedom*, Oxford University Press, chapter 5, and (2009), *Between Authority and Interpretation*, Oxford University Press, chapter 5.

<sup>715</sup> Andrei Marmor (2019), 'Soft Law, Authoritative Advice and Non-Binding Agreements', 39 *Oxford Journal of Legal Studies* 507.

<sup>716</sup> *ibid.*

<sup>717</sup> Jim Rossi and Jody Freeman (2021), 'Agency Coordination in Shared Regulatory Space', 125 *Harvard Law Review* 1131.

<sup>718</sup> *ibid.*, p. 1151.

<sup>719</sup> *ibid.*, p. 1188.

<sup>720</sup> *ibid.*, p. 1142.

<sup>721</sup> *ibid.*, p. 1151.

At least some of these ideas can be extrapolated to the EU context, where a shared space is a necessity to begin with, in light of the multi-level governance of the EU. However, beyond the simple national-supranational allocation of competences, there are further overlaps and complexities resulting from the gradual agencification process, and, in the case of finance, the coexistence of structures with different degrees of integration and inspired by different philosophies. These structures comprise, on one hand, the European System of Financial Supervisors (ESFS) including the ESAs (European Banking Authority (EBA), European Securities and Markets Authority (ESMA) and European Insurance and Occupational Pensions Authority (EIOPA), respectively for banking, securities markets and insurance and occupational pensions) and the European Systemic Risk Board (ESRB), and, on the other hand, the Banking Union, with the Single Supervisory Mechanism (SSM) and the Single Resolution Mechanism (SRM) respectively with the ECB and the Single Resolution Board (SRB) at the top. Changing from this design to a more streamlined version may be undesirable, and is, for all purposes, unrealistic.

Thus, this means not only that different institutions, agencies and bodies (both national and supranational) must coordinate their actions. They have to do so in the understanding that the coexistence is not merely duplicative, but has a certain meaning, which has to be respected. And the meaning of the 'shared space' in each case, shapes the rationale for coordination, and for the authority that may be attached to each legal act.

## 4 ECB opinions and shared normative space: evolution and legal scrutiny

### 4.1 The ECB's shared normative space: overlapping layers<sup>σ</sup>

If some key functions of soft law depend on the configuration of the shared normative space, the analysis of such space has to focus on its concrete features and be conscious of its changes. This is important for the ECB, and the field of financial regulation and policy, where the shared normative space has greatly evolved.

Starting with the initial, or core ESCB role in the Treaties, this followed a dual structure, with the ECB and the National Central Banks (NCBs).<sup>722</sup> The governance structure of the ESCB permitted the ECB to 'lend' its bodies to the ESCB, including policy setting by the Governing Council, with delegation of some tasks to the Executive Board. Both would coordinate with NCBs, which, in turn, have a role thanks to the principle of

---

<sup>σ</sup> The relevance of ECB opinions, and ECB soft law depends on the configuration of its 'shared normative space'. This is complicated, because such space does not reflect a single normative design, but overlapping designs with different rationales.

<sup>722</sup> Florian Becker (2022), 'Article 129 [Structure of the ESCB; Statute]' in Helmut Siekmann (ed.), *The European Monetary Union. A Commentary on the Legal Foundations*, Hart Publishing, pp. 360-368; Michael Ioannidis (2020), 'The European Central Bank' in Fabian Amtenbrink and Christoph Herrmann (eds.), *The EU Law of Economic and Monetary Union*, Oxford University Press, pp. 356-366.

'decentralised implementation',<sup>723</sup> and the composition of the Governing Council itself.<sup>724</sup>

A salient feature is the design's 'internal', or 'inward' focus. The ECB interacts with NCBs and vice versa, and policymaking mostly occurs within this circle. Most of the instruments cited in the Treaties and ESCB Protocol, such as guidelines, decisions and instructions, are issued by the Governing Council (or, sometimes, the Executive Board) and directed exclusively to NCBs.<sup>725</sup> Much of the activity takes place in a 'closed loop'.

As a flip side, the 'external' projection of activity is relatively limited. NCBs interact with third parties, following the principle of decentralised implementation. The ECB's powers of compliance and enforcement are not very explicit. The Protocol recognises the NCBs' duty to act in accordance with the ECB's guidelines and instructions, and the ECB's power to ensure compliance,<sup>726</sup> but does not give much detail about how this may happen.<sup>727</sup> The ECB may bring infringement actions for breach of their obligations only against NCBs,<sup>728</sup> despite such breaches may be committed by other national bodies, including legislators and other policymakers. The ECB has a direct action against Member States in cases where NCBs governors are relieved from office in breach of EU Law.<sup>729</sup>

In this broader context, ECB opinions could be less frequent, but definitely relevant. The legislative or regulatory areas affecting the ECB's responsibilities or expertise would be narrower, but very significant, since the smooth implementation of 'pure' monetary tasks and central bank independence are essential, and ECB opinions would thus ensure that legislators consider central bank 'core' functions.

In a subsequent stage, in the aftermath of the Great Financial Crisis, the ECB's shared normative space was characterised by conflicting signals. In the initial stages of the crisis, EU policymakers promoted the Lamfalussy architecture,<sup>730</sup> with the post-De Larosiere<sup>731</sup> adjustments, emphasising the role of the European Commission. Additionally, they underscored the significance of the committees of national

---

<sup>723</sup> Becker (n 28), pp. 370-373; Ioannidis (n 28), p. 359.

<sup>724</sup> Becker (n 28), p. 380.

<sup>725</sup> *ibid.*, p. 374.

<sup>726</sup> Article 9 (2), 12 (1) and 14 (3) of Protocol No. 4 on the Statute of the ESCB and the ECB (OJ C 202, 7.6.2016, p. 230).

<sup>727</sup> Article 14 (3) of the protocol states that 'The national central banks are an integral part of the ESCB and shall act in accordance with the guidelines and instructions of the ECB. The Governing Council shall take the necessary steps to ensure compliance with the guidelines and instructions of the ECB, and shall require that any necessary information be given to it'.

<sup>728</sup> Article 35 (6) of the Protocol, mirroring Article 271 (d) TFEU, states that: "The Court of Justice of the European Union shall have jurisdiction in disputes concerning the fulfilment by a national central bank of obligations under the Treaties and this Statute. If the ECB considers that a national central bank has failed to fulfil an obligation under the Treaties and this Statute, it shall deliver a reasoned opinion on the matter after giving the national central bank concerned the opportunity to submit its observations. If the national central bank concerned does not comply with the opinion within the period laid down by the ECB, the latter may bring the matter before the Court of Justice of the European Union".

<sup>729</sup> Judgment of 26 February 2019, *Rimšēvičs*, C-202/18 and C-238/18, ECLI:EU:C:2019:139.

<sup>730</sup> [https://finance.ec.europa.eu/regulation-and-supervision/regulatory-process-financial-services\\_en](https://finance.ec.europa.eu/regulation-and-supervision/regulatory-process-financial-services_en)

<sup>731</sup> The High-Level Group of Financial Supervision in the EU Chaired by Jacques De Larosière, Brussels, 25 February 2009.

authorities, later transformed into ESAs on Banking, EBA, ESMA, EIOPA, which – together with the ESRB and national supervisors – form the ESFS.<sup>732</sup>

The committees' 'internal' dimension, with the interplay between national and EU levels, were complemented with a strong 'external' projection in the norm production process. Together with the European Commission, the ESAs would be relied upon to produce preparatory acts, such as Regulatory and Implementing Technical Standards (RTS – ITS),<sup>733</sup> and quasi-applicative acts, such as guidelines.<sup>734</sup> 'Opinions' and 'consultations' would follow this trail, with a prominent role for the ESAs and ESRB. A brief look at the Capital Requirements Directive (CRD) or Regulation (CRR) shows that the ESRB or EBA (more rarely other ESAs) are the authorities to be consulted on multiple matters.<sup>735</sup> In contrast, mentions to the consultation of the ECB are rare,<sup>736</sup> but not completely absent. Thus, one cannot conclude that the co-legislators forgot the ECB, or were relying on Article 127 (4) TFEU. Rather, they seemed to deliberately prioritise the EFSF architecture in the norm production process, including as a source of consultation and input. The ECB's role would be indirect, through the ESRB.

However, as the financial crisis morphed into a sovereign debt crisis, the insufficiency of the ESFS to restore confidence to the financial system soon became evident. The ECB, after its pledge to 'do whatever it takes' to save the euro, took centre stage. In the process of setting up the European Stability Mechanism (ESM) and putting together financial assistance packages for troubled Member States, the ECB was a member of the 'troika',<sup>737</sup> and, despite insisting on a secondary role, to put distance between its monetary role and the 'economic' dimension of the assistance

---

<sup>732</sup> <https://www.bankingsupervision.europa.eu/about/esfs/html/index.en.html>

<sup>733</sup> Regulation (EU) No 1093/2010 of the European Parliament and of the Council of 24 November 2010 establishing a European Supervisory Authority (European Banking Authority), amending Decision No 716/2009/EC and repealing Commission Decision 2009/78/EC (OJ L 331, 15.12.2010, p. 12), Regulation (EU) No 1094/2010 of the European Parliament and of the Council of 24 November 2010 establishing a European Supervisory Authority (European Insurance and Occupational Pensions Authority), amending Decision No 716/2009/EC and repealing Commission Decision 2009/79/EC (OJ L 331, 15.12.2010, p. 48), Regulation (EU) No 1095/2010 of the European Parliament and of the Council of 24 November 2010 establishing a European Supervisory Authority (European Securities and Markets Authority), amending Decision No 716/2009/EC and repealing Commission Decision 2009/77/EC (OJ L 331, 15.12.2010, p. 84) (ESAs Regulations), Articles 10, 15.

<sup>734</sup> Article 16 ESAs Regulations.

<sup>735</sup> Directive 2013/36/EU of the European Parliament and of the Council of 26 June 2013 on access to the activity of credit institutions and the prudential supervision of credit institutions and investment firms, amending Directive 2002/87/EC and repealing Directives 2006/48/EC and 2006/49/EC Text with EEA relevance (OJ L 176, 27.6.2013, p. 338) (CRD), Articles 21b (9) (intermediate EU parent), 78 (9) (benchmarking of internal models), 89 (3) and (6) (country reporting, EBA, ESMA, EIOPA), 127 (third country equivalence of consolidated supervision), 131 (3) (O-SIIs, EBA's consultation of ESRB before issuing guidelines) and (5a) (ESRB and EBA, OSIs buffer), 133 (6) (systemic risk buffer, EBA's consultation of ESRB before issuing guidelines); Regulation (EU) No 575/2013 of the European Parliament and of the Council of 26 June 2013 on prudential requirements for credit institutions and investment firms and amending Regulation (EU) No 648/2012 (OJ L 176, 27.6.2013, p. 1) (CRR), Articles 458 (9) (macroprudential requirements at Member State level) 461 (1) (phasing-in of liquidity coverage requirement, EBA's report to Commission, after consulting ESRB), 500c (1) (dedicated prudential treatment of sustainability-related exposures, EBA report to the Commission, after consulting the ESRB), 503 (1) and (3) (covered bonds, consultation of EBA), 504 (subscription of capital instruments by public authorities in emergency situations, consultation of EBA), 509 (liquidity requirements, consultation of EBA and ESRB), 510 (2) (net stable funding requirements, EBA report, after consulting ESRB).

<sup>736</sup> Articles 161 (9) CRD (EBA's report to the Commission on credit institutions' use of LTRs), CRR article 509 (1) (liquidity requirements, consultation of ESRB central banks) and (3) (high and extremely high liquidity and credit quality assets).

<sup>737</sup> European Stability Mechanism (2019), *Safeguarding the Euro in Times of Crisis. The Inside Story of the ESM*, chapter 8 'Enter the troika: the European Commission, the IMF, the ECB'.

programmes,<sup>738</sup> its role was key to bring credibility. Thus, the ECB 'advisory' role would be crucial to verify that the reforms adopted were on the right track. This also explains the disproportionate presence of opinions requested by Member States under financial assistance programmes in the total number of opinions issued by the ECB, as recounted in Diane Fromage's contribution.<sup>739</sup>

Thus, during this 'intermediate' stage, the ECB would see the 'external' projection of its activity in the norm-producing process (including its advisory role) diminished, or 'hidden' behind the ESRB, on one hand, and enhanced, as a result of financial assistance programmes, on the other hand. Even though it did not fit the institutional design envisaged initially, the ECB occupied centre stage as a matter of necessity.

Finally, in a third stage of evolution, the Banking Union and the SSM vested the ECB with broad competences on financial supervision,<sup>740</sup> and an arguably greater centralisation of competences than the 'core' central banking architecture. As held by the Court of Justice, rather than 'sharing' or 'distributing' competences, the SSM vested all the competences on the ECB, and NCAs would then assist the ECB in the decentralised implementation of some of those tasks.<sup>741</sup> It is hard to overstate the importance of this. The ECB's new tasks multiplied the ECB activity's external projection and direct interaction with credit institutions, including by means of intrusive powers. Furthermore, unlike a monetary 'core', which may be stretched but has a limit, having monetary policy (as well as foreign exchange and payments) and supervision as two vertices allows to 'triangulate' a much greater area as justifiably impinging upon the ECB's functions, let alone as benefitting from the ECB's expertise, to borrow from the Court's language in *OLAF*.

This mutation of competences also affected the list of soft law acts produced by the ECB. An initial study, based on its initial, central banking core, included a list of acts that closely followed the list in the Treaty and Protocol (regulations, decisions, guidelines and instructions, and non-binding recommendations and opinions).<sup>742</sup> Another study, post-SSM,<sup>743</sup> included the Treaty-based acts (regulations, decisions, recommendations and opinions), SSM Regulation acts (guidelines and instructions, although these could be case-specific and general<sup>744</sup>) and, in addition, rules and guidance, options and national discretions, the Supervisory Review and Evaluation Process (SREP) and aggregate statistical data (published under the ECB's

---

<sup>738</sup> See, e.g., Exchange of views of Benoît Cœuré with ECON on troika matters, introductory remarks by Benoît Cœuré, Member of the Executive Board of the ECB, Brussels, 13 February 2014, available at: <https://www.ecb.europa.eu/press/key/date/2014/html/sp140213.en.html>. In the Judgment of 16 June 2015, *Gauweiler*, C-62/14, ECLI:EU:C:2015:7, the Court did not see any problem, but AG Villalón's Opinion of 14 January 2015 (ECLI:EU:C:2015:7) concluded that the Outright Monetary Transactions (OMT) programme for sovereign debt of countries subject to financial assistance programs could be considered a 'monetary' program if the ECB refrained from any direct involvement in said program (*ibid.*, paras. 150-151).

<sup>739</sup> See Diane Fromage, 'ECB opinions on national legislative proposals: Practice to date and Outlook'.

<sup>740</sup> SSM Regulation

<sup>741</sup> Judgment of 8 May 2019, *Landeskreditbank*, C-450/17 P, ECLI:EU:C:2019:372, paras. 37-41.

<sup>742</sup> European Central Bank (1999), *Monthly Bulletin*, November, p. 53.

<sup>743</sup> Rinxe Bax and Andreas Witte (2019), 'The taxonomy of ECB acts available for banking supervision', *Economic Bulletin*, Issue 6, p. 85.

<sup>744</sup> *ibid.*

'supervisory disclosure' obligations<sup>745</sup>), as well as 'policy documents', with different labels ('Policy stance', "Guidance", "Joint Supervisory Standard", "Methodology", "Guide", "Letter"<sup>746</sup>). The explanation of the norm emergence process under the logic of social norms highlights the role of soft law as a form of communication, incorporating coordination and authority. This provides definitive evidence that the ECB is becoming more vocal and assertive in its policy-related communication towards other institutions and the public.

The effect of this on opinions is more mixed. On one hand, the ECB has more tools to assert the views it may initially, and more tentatively, express in an opinion, and thus they can be crucial to understand the context and finality of other soft law acts, or legally binding acts. On the other hand, the greater availability of other acts means that those acts closer to the applicative stage (e.g., guidelines, SREP manuals, etc.) may be more important due to their concretion.

## 4.2 ECB opinions in the courts<sup>σ</sup>

Under the view presented here, ECB opinions are treated as part of ECB's soft law, and soft law comprises acts that are not legally binding, but seek to shape 'social norms', and become legal norms. This shows that soft law should not be seen in a negative light. Instead of through backroom deals, it promotes normative changes through open exchange, as a source of information diffusion, coordination and authoritative advice. Yet, soft law must be subject to controls to ensure that it responds to that role. Thus, legal accountability should control that soft law is used 'virtuously', for these purposes, and does not present 'pathologies', such as disinformation (or reckless handling of information), omission of essential procedural requirements, or misuse powers.

If legal accountability controls soft law's 'dark' side, its actual role will depend, at least in part, on the configuration of the shared normative space, and how sensitive is the function performed by the soft law act, or the pathology allegedly incurred, to the shape of that normative space. In principle, not all functions are equally sensitive.

The role of soft law as a source of information is *prima facie* not the most sensitive to the shape of the normative space. All public institutions and norm-producing bodies should be expected to handle information objectively, and to not mislead the public, as a premise for the norm emergence process to take place; this does not (at least should not) depend on the role each institution occupies in the normative process. Thus, an institution could be held responsible for statements and opinions, even if it has not issued as a binding act. Case-law bears this out. In *Arizmendi*, the General Court held that the European Commission's reasoned opinion on the (in)compatibility

---

<sup>745</sup> *ibid.*

<sup>746</sup> *ibid.*

<sup>σ</sup> In the account of soft law offered before, the role of the courts should be to ensure that soft law fulfils its functions of information, coordination and authority properly, and limit its 'pathological' use. For opinions in particular, the control of the 'information' dimension cannot depend on whether the act is binding. For controlling 'coordination', Courts should use a pragmatic approach on the scope of the duty to consult, including the matters on which the ECB actually performs tasks, and a more cautious approach about the consequences of a failure to consult

of national ship brokers with EU measures could be the basis for a damages action for non-contractual liability, even if the ‘opinion’ itself was not a binding act, if, e.g., disclosed confidential information, or contained inaccurate information likely to cause harm.<sup>747</sup> In *Steinhoff*, the General Court went further to hold that, if the Court had no jurisdiction to examine whether the elements of the damages action (serious breach of EU Law, and causation of damage), in particular whether an ECB’s opinion constituted a sufficiently serious breach of EU Law, it would deprive the remedy of its purpose and effectiveness.<sup>748</sup> This outcome is aligned with the idea that information and opinions contribute to the formation of social norms, and can crystallise in legal norms, and thus can mislead parties; hence, it should be subject to some level of monitoring. Also aligned is the Court’s use of a very high threshold of liability, whereby the institution, agency or body must have “manifestly and gravely disregarded” the limits of its discretion.<sup>749</sup> This is consistent with a view where, if soft law facilitates norm emergence by means of information sharing, the legal framework should enable such information sharing, rather than hinder it, and only in cases where the information can distort or manipulate the discussion, or where it is recklessly handled, should the prospect of liability be entertained. In practice, this means that actions in damages against opinions should be admissible, but seldom enforced.

As the only constructive criticism, the Court seems to reach the correct outcome, but without clarifying how it gets there. In *Steinhoff*, the General Court eventually ruled out any liability of the ECB due to the non-binding nature of its opinions, and the ECB’s discretion in producing them to exclude liability. However, if these factors are present in every opinion, why should a damages action be admissible at all?<sup>750</sup> The answer would require explaining how an opinion can cause damages other than by means of a binding act. This, in turn, would require the Court to adjust the damages action to cases of ‘liability for misstatements’. Some relevant considerations in such cases are whether the maker of the statements is subject to a specific duty of care, and/or whether third parties can be expected to reasonably rely on the statement. In principle, the ECB (or any other institution, agency or body) should not be made subject to a duty beyond that of handling the information objectively, and without manifest disregard for the truth, and third parties could not be expected to reasonably rely on the ECB’s opinion as a basis for their action, but to wait until the normative action of the competent party (national or EU legislator or regulator) is adopted.

If the Court chose to develop its doctrine on non-contractual liability in the direction pointed above, it would clarify that, even if their claim is admissible, plaintiffs need to show something else beyond a non-binding opinion, such as evidence that crucial information was blatantly disregarded, or, more likely, some specific circumstances showing that the ECB (or the maker of the statement) was subject to a stricter duty of

---

<sup>747</sup> Judgment of 18 December 2009, *Arizmendi and Others v Council and Commission*, T-440/03, T-121/04, T-171/04, T-208/04, T-365/04 and T-484/04, ECLI:EU:T:2009:530, paras. 66 to 69.

<sup>748</sup> Judgment of 23 May 2019, *Steinhoff*, T-107/07, ECLI:EU:T:2019:353, paras. 53-56.

<sup>749</sup> *ibid.*, para. 53.

<sup>750</sup> See Diane Fromage (2020), ‘The ECB and its expanded duty to respect and promote the EU Charter of Fundamental Rights after the *Steinhoff* case’ *EU Law Live* with a very sharp analysis suggesting that the admissibility of damages actions against non-binding acts should be given further thought. Even if this contribution reaches a different conclusion, the objections raised in the piece, based on the uncertainty that such a jurisdictional stance may cause remain valid. This is why it would be desirable for the Court to delineate a clearer path for the specificities of claims of liability for misstatements.

care, or that third parties could be expected to rely on the opinion. This would make it possible to take account of the specific role of the ECB opinion in the shared normative space in specific cases. For example, in cases where countries under financial assistance programmes were expected to comply with the ECB's assessment as part of their obligations under conditionality programmes. This, however, would not lead to holding the ECB liable, since the plaintiffs would still have to show that the ECB's 'false' statement was due to gross negligence, something that would keep the assessment of these cases aligned with the Court's general doctrine for the damages action in non-contractual cases.

The role of soft law as a source of coordination is more sensitive to the configuration of the shared normative space. In principle, the implication in the case of opinions that are clearly not binding, the question is (i) whether there was a duty to consult in the specific case, and (ii) what are the consequences of not fulfilling that duty.

The question whether there was a duty to consult depends on how to interpret the Council Decision of 1998, and the Court of Justice's view in the *OLAF* case discussed before.<sup>751</sup> The more glaring sign that the Decision has not kept up with the times is that it still says that the ECB shall be consulted by national authorities with regard to 'rules applicable to financial institutions insofar as they materially influence the stability of financial institutions and markets'. It would be much more aligned with the current allocation of competences if the Decision simply referred to 'rules applicable to financial institutions', perhaps qualifying it with a reference to prudential regulation and supervision. As it stands, the provision leaves open the question of how liberally, or how strictly, should one interpret the reference to 'materially influence the stability'.

The *OLAF* case-law can help interpret the Council Decision to keep up with the times, although this, too, requires understanding the meaning of the Court's statement in paragraph (110), that the duty to consult the ECB was intended to ensure that the legislators heard the views of a body (i) that has certain 'competences' to be interpreted in light of the Chapter on 'monetary policy', (ii) that 'exercises specific functions', and (iii) that has a high degree of expertise, which make it particularly well placed to play a useful role. The conclusion in *OLAF* was easy, because the ECB did not have competence, functions or expertise in the area of the prevention of fraud. The problem will not be as easy in other cases, where the ECB may have expertise, but not 'functions' or 'tasks', or it may have 'functions' or 'tasks', but these do not fit squarely within 'monetary policy', or the list of tasks under Article 127 (2) TFEU.

Reading the Court's statement through the reference to concrete 'functions' or 'tasks' (functional view) seems the correct approach. Distinguishing a subset of those functions (the monetary functions) as shaping the scope of the duty to consult due to their 'constitutional pedigree', would be at odds with the Court's pragmatic approach, and based on the practical reality of the tasks actually performed by the ECB. As long as such tasks are lawfully conferred, the ECB should be consulted if they are affected. Instead of second-guessing the conferral by appealing to the ECB's 'constitutional essence', courts should try to foster the consistency between the tasks performed, and EU and national legislation. For the same reason, one should reject the reference

---

<sup>751</sup> *OLAF* (n 5).



to 'expertise' as a defining feature of the test to determine when there is a duty to consult. It would make the test unworkable in practice, and it would be dangerous, as the ECB could expand the obligation to consult by simply hiring more experts on different fields. In some of these fields, like climate change, where the ECB has created a 'climate centre', it would go against the ECB's repeated claims that it is a 'policy taker', not a 'policy maker'.

In any event, if the Court were to follow a narrower interpretation in light of the text of the Council Decision, and not based on the actual reality of the tasks actually performed by the ECB, this interpretation should be confined to the scope of the Decision, i.e., the duty to consult by Member States. It should not extend to the duty to consult by EU authorities, where the considerations of the *OLAF* case discussed in the previous section would apply in their entirety.

The question of what should be the consequences in case of non-compliance with the duty is also problematic. Lambrinoc argues that a failure to consult could amount to the breach of an 'essential procedural requirement'.<sup>752</sup> She concludes that the consequence may be the voidness of the measure, drawing on the Court's case-law where, e.g., the Council failed to consult the European Parliament, or failed to give it sufficient time to express its views,<sup>753</sup> or failed to consult the Council, or the Consultative Council of the High Authority,<sup>754</sup> or the Economic and Social Committee.<sup>755</sup>

However, a second look shows that things are far from simple. In its case-law, the Court has not emphasised the duty to consult in the abstract, but in the concrete context, in light of the institution to be consulted, and the meaning of consultation. Thus, in cases of European Parliament's consultation, it emphasised that the European Parliament's effective participation was essential for institutional balance, as it reflected the fundamental democratic principle.<sup>756</sup> In other cases, the Court did not delve deep into the duty to consult because the case fell outside that duty,<sup>757</sup> or the consultation had effectively taken place.<sup>758</sup> From this case-law, it appears that the Court approaches the duty to consult in a finalistic manner, i.e., when consultation is instrumental to ensure protect institutional balance (e.g., to ensure that the Member States' interests are considered) or fundamental principles, such as democratic legitimacy, EU Courts take a stricter approach, and the act's voidness may follow

---

<sup>752</sup> Simona Elena Lambrinoc (2009), 'The Legal Duty to Consult the European Central Bank. National and EU Consultations', *ECB Legal Working Paper Series*, November, p. 12.

<sup>753</sup> *ibid.*, citing Judgment of 10 June 1997, C-392/95, *Parliament v Council*, [1997] ECLI:EU:C:1997:289, para. 24; Judgment of 16 July 1992, C-65/90, *Parliament v Council*, ECLI:EU:C:1992:325, para. 21, among others.

<sup>754</sup> *ibid.*, citing Judgment of 21 March 1955, 6/54, *Netherlands v High Authority*, ECLI:EU:C:1955:5, p. 112. See also Judgment of 21 December 1954, 1/54, *France v High Authority*, ECLI:EU:C:1954:7, p. 15 and Judgment of 21 December 1954, 2/54, *Italy v High Authority*, ECLI:EU:C:1954:8, p. 52.

<sup>755</sup> *ibid.*, citing Judgment of 9 July 1987, 281, 283, 284, 285 and 287/85, *Germany and others v Commission*, ECLI:EU:C:1987:351, para. 38.

<sup>756</sup> For instance, *Parliament v Council* (n 59), para. 14. The principle was formulated first in Judgment of 29 October 1980, 138/79, *Roquette Frères v Council*, ECLI:EU:C:1980:249, para. 33.

<sup>757</sup> For instance, *France v High Authority* (n 60), p. 15 (Consultative Committee of the High Authority), or *Germany and others v Commission* (n 61), para. 39 (Economic and Social Committee – the act fell outside the scope of the duty to consult, and, crucially, was declared void because the Commission exceeded its powers).

<sup>758</sup> For instance, *Netherlands v High Authority* (n 59), p. 112.

almost automatically. However, the ECB is not the European Parliament nor the Council, and cannot benefit from this automatism.

All this calls for a cautious approach. This contribution advocates a relatively broad scope for the duty to consult, based on a finalistic and pragmatic view, in line with the Court's in *OLAF*; one that takes into account the tasks that the ECB effectively performs. However, this also requires accepting that those tasks fall in a normative space that is shared, it is not clearly delineated, nor obeys a single design, which can be a source of uncertainty. If the uncertainty about the existence of the duty to consult is compounded by the voidness of the resulting act, as the remedy of the breach of such duty, this could give rise to a large amount of 'zombie' legislation, which would be a clearly negative consequence.

Therefore, it is useful to take a step back to see that the 'failure to consult' is analysed by the Court as part of its case-law on breach of 'essential procedural requirements'. This case-law also includes instances where the consultation involved interested parties, among other safeguards,<sup>759</sup> and the Court did not mechanically apply voidness as a remedy. Instead, it analysed whether, absent the procedural irregularity the decision might have been different, i.e., what could be the impact on its content.<sup>760</sup> Thus, instead of declaring the act automatically void, in a case where the ECB has allegedly not been consulted, the Court should examine how this could have affected the content of the measure, and thus whether a concrete provision that creates frictions and inconsistencies can be disapplied or reinterpreted, instead of rendering the entire legal act ineffective.

## 5 Conclusions

Opinions are fluid. People change their opinions in contact with other people and other opinions. Institutions are no different, and the law should take this into consideration when determining how to deal with said opinions.

However, it does not follow that opinions are shapeless, irrelevant speculations. Some opinions are extremely influential on institutions and the public. Certain frameworks can turn opinions into an authoritative source, or, like Article 127 (4) TFEU create an obligation to ask for an opinion. Thus, context matters, including the substance of the opinion, the institution issuing the opinion, and the procedure where it is, or should be issued.

Dealing with this variable reality requires a suitable framework. This contribution proposes to treat ECB opinions as part of 'soft law', understood more broadly as the instruments produced by institutions that facilitate the emergence of 'social norms', which may crystallise into legal norms. In such context, soft law operates as a source of information, coordination and authority, elements that may be present with different

---

<sup>759</sup> Judgment of 29 October 1980, 209 to 215 and 218/78, *Van Landewyck v Commission*, ECLI:EU:C:1980:248, para. 47; judgment of 11 March 2020, C-56/18 P, *Commission v. Gmina Miasto Gdynia*, ECLI:EU:C:2020:192.

<sup>760</sup> See, e.g., *Van Landewyck v Commission* (n 65), para. 47; *Commission v. Gmina Miasto Gdynia* (n 65), para. 153.

intensity depending on the soft law act, but also of its context. Such context is summarised in the idea of 'shared normative space', which determines which institutions contribute to the process, and how they do so, with opinions, preparatory acts, or applicative guidance, and thus what is the significance of each act.

This approach offers an advantageous standpoint to deal with soft law in general, and opinions in particular. Rather than something shady or dubious, soft law (including opinions) fosters norm emergence in the open, and makes it easier to track such emergence. Yet, problems may still arise, wherever the functions of information, coordination and authority are mishandled. Courts are essential to make the process accountable. EU Courts' doctrines show the correct approach, with a good combination of flexibility, purposive approach, and emphasis on accountability. However, as soft law instruments proliferate, and the flexibility of opinions is exploited to shape the normative process and fill its gaps, those doctrines will be increasingly tested, and will require adjustment.

# To consult, or not consult: the question on the legal consequences

Miguel Sampol Pucurull\*

## 1 Introduction

To what extent is it crucial to ensure that the legislature is well-informed when a legislative measure to be adopted falls in a technical and complex area as monetary policy? When the legislation provides an obligation to consult a specific body or organ by virtue of its high degree of expertise, what consequences have to be drawn if this consultation is not submitted or fully followed? If the obligation is laid down in primary law, will the outcome be affected?

These specific questions are not new in the Member States, and it is quite common for Supreme Courts or the highest jurisdictions to declare a legislation void and null in the absence of a compulsory prior consultation, even though the opinion given by the expert body is not binding<sup>761</sup>.

This contribution tries to address these questions by focusing on situations where the consultative organ is a key institution in the area of monetary policy, as well as in other fields, in which the European Central Bank (ECB) has progressively been given a much important role. One of its main purposes is to test the legal arguments contended in section 6 of the guide to consultation of the ECB by national authorities regarding draft legislative provisions, which refers to the question of the legal consequences of non-compliance with the obligation to consult the ECB<sup>762</sup>.

The chapter will refer to the legal basis establishing an obligation to consult the ECB in primary law (part 2). It will examine the nature of the opinion given by the ECB as well as the procedural nature of an obligation to consult (part 3). In doing so, it will be important to take into account the case-law of the European Court of Justice (ECJ) regarding the obligation to consult established in primary or secondary law within the framework of the preparation of EU legislation or national legislation (part 4). Based on this analysis, it will be worthwhile to address the eventual enforceability of a piece

---

\* Judge at the EU General Court

<sup>761</sup> For instance, concerning draft laws to be discussed in the French Council of Ministers, it is provided that any discussion on the draft text is based on a previous opinion adopted by the Conseil d'Etat. Failure to comply with this requirement, the provision from the draft law is submitted to an irregular procedure. Judgment from the Conseil Constitutionnel, 3 April 2003, déc. n° 2003-468 DC, points 5-9; OJ 12 April 2003, p. 6493 and Judgment from the Conseil Constitutionnel 28 December 1990, déc. n° 90-285 DC, points 5 to 6; OJ 30 December 1990, p. 16609. Similarly in Spain, the adoption of technical regulations by the Government are subject to the consultation of the Council of State (Consejo de Estado). Failure to provide this consultation, the draft law is considered null and void. See among others the judgment from the Supreme Court 20th of February 2019, decisión number 205/2019, ECLI:ES:TS:2019:626, point 2 of the legal arguments.

<sup>762</sup> European Central Bank (2015), *Guide to consultation of the European Central Bank by national authorities regarding draft legislative provisions*, Frankfurt am Main, October, p. 27.

of legislation in the absence of the notification provided in Article 127(4) Treaty on the Functioning of the European Union (TFEU) (part 5), as well as what legal remedies are provided by the Treaties (part 6). Against this background, some conclusions may be drawn in a new area where there is no ECJ case-law yet (part 7).

## 2 Legal basis on the obligation to consult the ECB

When the drafters of the Treaties envisaged a path to create a European Monetary Union, they designed an institutional system where different independent, technical, and expert bodies would have a significant role either in the design or implementation of the monetary policy. It was the case with the European Monetary Institute and, more recently, the ECB, whose competences have been extended. An important element of the institutional system created by the Treaties was the possibility to give advice on the field of competence of the former and on the fields of competence of the latter<sup>763</sup>.

The idea of having to ask for an opinion is reflected in several provisions of the Treaties which contain a legal basis requiring or allowing the ECB to be consulted when taking a decision likely to affect its fields of competence or its structure. Within this framework, a distinction can be made between a general and a specific legal basis. The former refers to the duty to consult the ECB in certain areas and also the possibility of giving advice on its own motion. This is the legal basis examined in this contribution. The remaining legal basis provided for in the Treaties relate to specific areas affecting the function or the powers of the ECB.

Article 127(4) TFEU establishes the general legal basis on the consultation to the ECB according to which:

"The European Central Bank shall be consulted:

- on any proposed Union act in its fields of competence,
- by national authorities regarding any draft legislative provision in its fields of competence, but within the limits and under the conditions set out by the Council in accordance with the procedure laid down in Article 129(4).

The European Central Bank may submit opinions to the appropriate Union institutions, bodies, offices or agencies or to national authorities on matters in its fields of competence."

Protocol No 4 on the Statute of the European System of Central Banks and the European Central Bank (ESCB's Protocol) annexed to the Treaties also contains the exact same text in its Article 4.

There are other legal provisions in the Treaties which stipulate consultation of the ECB. Firstly, the Treaty on the European Union (TEU) provides for the consultation of

---

<sup>763</sup> In order to interpret the change of the singular versus the plural in the terms "fields of competence", it is useful to read the opinion of Advocate General Jacobs delivered on the 3rd of October 2002, Case C-11/00, *Commission v ECB*, ECLI:EU:C:2002:556, in particular, point 139, in the so-called "OLAF case".

the ECB when an ordinary or simplified revision procedure of the Treaties is engaged in the case of institutional changes in the monetary area.

Secondly, the TFEU contains specific provisions requiring prior consultation of the ECB in specific areas, such as the adoption of safeguard measures in relation to the free movement of capital (Article 66 TFEU) and the replacement of the protocol on the excessive deficit procedure (Article 126 TFEU). The ECB is also consulted in various situations before the Council adopts any measure or decision in cases identified by the TFEU. It is the case when the Council may adopt measures to harmonise the denominations and technical specifications of all coins intended for circulation [Article 128(2) TFEU], certain amendments to Protocol No 4 or specific decisions provided in that protocol [Article 129(3) and (4) TFEU] or when the Council adopts detailed provisions concerning the composition of the Economic and Financial Committee [Article 134(3) TFEU].

The TFEU also focuses on the external aspect of the monetary policy. The ECB is also consulted when the Council envisages adopting common positions on matters of particular interest for Economic and Monetary Union or taking appropriate measures to ensure a unified representation within the competent international financial institutions and conferences (Article 138(1) and (2) TFEU). Article 219 TFEU establishes the obligation to consult the ECB if the Council intends to conclude formal agreements on an exchange-rate system for the euro vis-à-vis the currencies of third countries or to adopt, adjust, or abandon the central rates of the euro within the exchange-rate system.

Finally, Article 41 of the ESCB's Protocol mirrors the obligation provided in Article 129(4) TFEU which requires consultation with the ECB when adopting certain decisions specified in the Protocol.

The Council Decision 98/415/EC of 29 June 1998 on the consultation of the ECB by national authorities regarding draft legislative provisions<sup>764</sup> further develops the consultative procedure by authorities from the Member States. Adopted in 1998, the Decision has not since been amended even though the tasks assigned to the ECB have evolved significantly. Article 1 of Decision 98/415/EC specifies the definitions to be applied for the purpose of implementing the legal act. Article 2 is essential as it identifies the fields of competence in which the authorities of the Member States shall consult the ECB. Although it refers generally to the field of competence of the ECB pursuant to the Treaties, there is a list of areas which should be interpreted as non-exhaustive. It seems that an important number of areas in which the ECB has been entrusted with specific tasks are not mentioned in the Decision. Articles 3 and 4 refer to procedural aspects of the consultation such as time-limits, urgency and, particularly the measures that each Member State is obliged to take to ensure effective compliance with the Decision. In particular, the Decision refers to the obligation to consult the ECB at an appropriate stage to enable both the authority initiating the procedure and the adopting authority to take into consideration the ECB's opinion.

---

<sup>764</sup> Council Decision of 29 June 1998 on the consultation of the European Central Bank by national authorities regarding draft legislative provisions (OJ L 189, 3.7.1998, p. 42).

### 3 The nature of the opinions issued by the ECB

When addressing the legal question relating to the nature of the ECB's consultation, two aspects may arise. The first one is the binding or non-binding nature of the consultation. The second is about the nature of the requirement from a procedural point of view. To understand the role of the ECB's consultation, it is essential to qualify the legal requirement. Is it compulsory to request an opinion before adopting an EU act or a national legislative provision in the ECB's fields of competence?

In the first place, according to Article 288 TFEU, to exercise the EU's competences, the institutions shall adopt regulations, directives, decisions, recommendations, and opinions. The ECB's opinion issued pursuant to the powers recognised by Article 127(4) TFEU correspond to the one referred to Article 288(1) TFEU and, as a consequence, has no binding force, as clearly stated in Article 288(5) TFEU.

The General Court has recently confirmed this interpretation based on the wording of the provisions of the Treaty in the context of an action for damages. In its judgment in the *Steinhoff and Others v ECB* case<sup>765</sup>, the General Court stated that "it is clear from those provisions that the ECB's opinions are not binding on national authorities. Indeed, according to recital 3 and Article 4 of Decision 98/415, national authorities are required only to take those opinions into account and they do not prejudice the responsibility of those authorities for the matters which are the subject of the draft legislative provisions concerned. It follows that in order to comply with the obligation to consult the ECB, the ECB must be able to make its views known effectively to the [national] authorities, but it cannot compel those authorities to abide by them. If the legislature had intended to make the ECB's intervention legally binding as to its content, it would have conferred on it a power of authorisation, not a power to issue opinions. For the reasons given in [a] paragraph [of the judgment] above, the fact that the ECB's opinions are not binding on national authorities does not automatically preclude those opinions from rendering the ECB liable." This statement was also confirmed in a General Court judgment on the 9<sup>th</sup> of February 2022, *QI and Others v Commission and ECB*<sup>766</sup>.

In both procedures on the potential non-contractual liability of the ECB, the General Court underscored the non-binding nature of the ECB opinions, but also concluded that even though the opinion of the ECB of the 17<sup>th</sup> of February 2012, adopted pursuant to Articles 127(4) and 282(5) TFEU, read in conjunction with the Council Decision 98/415/EC, could not legally bind national authorities, it was, in principle, capable of causing the ECB to incur non-contractual liability without prejudice to its broad discretion under Articles 127 and 282 TFEU and Article 18 of the ESCB's Protocol.

In the second place, regarding the nature of the procedural requirement to consult the ECB according to Articles 127(4) TFEU and 4 of the ESCB's Protocol, it is important

---

<sup>765</sup> Judgment from the General Court, 23rd of May 2019, *Steinhoff e.a. v ECB*, Case T-107/17, ECLI:EU:T:2019:353, point 71.

<sup>766</sup> Judgment from the General Court, 9th of February 2022, *QI e.a. v Commission and ECB*, Case T-868/16, ECLI:EU:T:2022:58, point 82. This judgment was appealed before the Court of Justice and the decision was delivered on 28<sup>th</sup> September 2023 (Case C-262/22 P, ECLI:EU:C:2023:714).

to examine whether this is an essential procedural requirement. This question was already a central element of discussion of one of the pleas of defence submitted by the ECB in the action for annulment that the Commission brought before the ECJ on a decision taken by the ECB in the so-called *OLAF* judgment (case C-11/00)<sup>767-768</sup>.

The Commission challenged a 1999 decision taken by the ECB on fraud prevention, and claimed that the ECB's Decision infringed Regulation (EC) No 1073/1999 of the European Parliament and of the Council of 25 May 1999 concerning investigations conducted by the European Anti-Fraud Office (OLAF)<sup>769</sup>. In contrast, as a second argument of defence, the ECB contented that the Regulation had to be interpreted as not applying to it as it did not fall within its fields of competence. Should the Court not follow this interpretation, it should declare the regulation unlawful, on the ground that it had been adopted in breach of Article 105(4) EC [currently Article 127(4) TFEU] and the principle of proportionality and, consequently, the Court should declare the regulation inapplicable, in accordance with Article 241 EC [currently Article 277 TFEU].

The judgment by the full court of the ECJ did not conclude on the nature of this procedural requirement, but restricted the answer to a functional interpretation of the Article<sup>770</sup>. In other words, it indicated that the obligation was intended to essentially ensure that the legislature adopted the act only after the body had been heard<sup>771</sup>. By contrast, the parties, the Commission, the European Parliament, the Council, the ECB, and the Kingdom of Netherlands did not contest, and the Advocate General agreed that the consultation under the former Article 105(4) TFEU (currently Article 127(4) TFEU) constituted an essential procedural requirement. This opinion underlines the fact that there is a consistent case-law of the ECJ that consultation requirements laid down in the Treaty are to be regarded as essential. The Advocate General's statement was based on the case-law concerning the obligation to consult the European Parliament under the Treaty of Rome or the obligation of the High Authority to consult the Council and the Consultative Committee under the European Coal and Steel Community Treaty (ECSC Treaty)<sup>772</sup>.

The qualification of the requirement to consult the ECB in a normative procedure at EU level or a national legislative procedure as an essential procedural requirement seems of the utmost importance in identifying the eventual legal consequences of its

---

<sup>767</sup> Judgment from the Court of Justice from the 10th of July 2003, *Commission v BCE*, Case C-11/00, ECLI:EU:C:2003:395.

<sup>768</sup> See Odudu, O. (2004), "Case C-11/00, Commission of the European Communities v. European Central Bank", *Common Market Law Review*, No 4, pp. 1073-1092; Santos Vara, J. (2014), "La independencia del Banco Central Europeo y el Banco Europeo de Inversiones frente a la Oficina Europea de Lucha contra el Fraude (OLAF): (comentario a las sentencias del TJCE de 10 de julio de 2003, Comisión c. BCE y Comisión c. BEI)" *Revista de derecho comunitario europeo*, Vol. 17, pp. 237-257. and Ziloli C., Hlaskova Murphy S. et Ioannidis M. (2021), The mandate of the ECB: legal considerations in the ECB's monetary policy strategy review, European Central Bank, Frankfurt am Main, p.29.

<sup>769</sup> Regulation (EC) No 1073/1999 of the European Parliament and of the Council of 25 May 1999 concerning investigations conducted by the European Anti-Fraud Office (OLAF) (OJ L 136, 31.5.1999, p. 1).

<sup>770</sup> An important number of authors examining this judgment qualified the interpretation by the Court of Justice (points 110 to 112) as a mere functional interpretation of the provision. See among others Würtz K., « The legal framework applicable to ECB consultations on proposed Community acts », *Euredia*, 2005/4, p. 283-327, in particular, pp. 299 and 326.

<sup>771</sup> Judgment from the Court of Justice from the 10th of July 2003, *Commission v BCE*, Case C-11/00, ECLI:EU:C:2003:395, point 110.

<sup>772</sup> See opinion of Advocate General Jacobs delivered on the 3rd of October 2002, Case C-11/00, *Commission v ECB*, ECLI:EU:C:2002:556, point 131.



omission. The fact that the ECJ has not concluded until now on this matter prevents to state a definitive position. Nevertheless, the existence of a body of case-law on the nature of the requirement to consult an EU institution or body in other areas could shed light and help draw conclusions for those situations in which the ECB may not have been involved although mandatory consultation was required. Against this background, it is important to examine not only the case-law mentioned by the opinion of Advocate General Jacobs, but also the one in other areas of EU law where consultation plays a specific role.

## 4 The case-law of the Court of Justice on the obligation to notify the adoption of measures

Advocate General Jacobs referred to the consistent case-law of the ECJ about the obligation to consult the European Parliament and that of the High Authority to consult the Council and the Consultative Committee under the ECSC Treaty to support his statement that the procedural step of consulting the ECB is clearly capable of affecting the content of a measure, and failure to comply with such a requirement must be capable of leading to the annulment of the measures adopted<sup>773</sup>. His opinion emphasises the role of the consultation in a specific procedure. He pointed out that the capability of the consultation to impact the content of the measures is relevant to determine if the procedural step is essential or not. A similar line of case-law has been developed by the ECJ in relation to notification obligations under primary or secondary law. Thus, it is possible to ascertain that in some cases primary or secondary law require only the obligation to notify the intention to adopt some measure whereas, in other provisions, this obligation is more precise as it requires consulting an institution, agency or body of the EU. In construing the obligation set out in the legal texts, the ECJ's case-law takes into account the classical methods of interpretation. The wording and purpose of the text – and, sometimes, the context – constitute the main elements to determine the scope of the obligation as well as the consequences of failing to notify the draft measures.

### 4.1 Obligation to notify the adoption of measures under primary law

#### 4.1.1 The obligation to consult the European Parliament

In the area of the common agriculture policy, the third subparagraph of Article 43(2) from the original Treaty of Rome (EC Treaty) laid down that the Council would decide by unanimity on a proposal from the Commission after consultation of the Assembly (European Parliament). An action for annulment introduced by several companies against the Council resulted in a milestone judgment for the role of the European Parliament as an institution, and also for the consequences of not complying with the

---

<sup>773</sup> *ibid.*, point 131 and, particularly, footnote 99.

obligation to consult that institution<sup>774</sup>. Under the wording of Article 43 EC Treaty, the ECJ in the *Roquette Frères v Council* case considered that this Article must be interpreted as meaning that the European Parliament plays an actual part in the legislative process, which constitutes an essential factor in the institutional balance, founded on the fundamental democratic principle that the people should take part in the exercise of power through the intermediary of a representative assembly. As a consequence, the judgment concluded that consultation of the European Parliament is an essential formality, and disregarding of it means that the measure concerned is void<sup>775</sup>. The facts of the case were quite specific. The Council had to adopt a new regulation on the area of the common agriculture policy as a matter of urgency, and requested the opinion from the European Parliament as required by Article 43(2) EC Treaty. Nevertheless, the European Parliament after some discussions at committee level did not reach a formal opinion, and decided not to schedule a new session to discuss it as a new European Parliament had to be elected. The decision recalled that an additional session could be held at the request of one of the institutions. The Council adopted the regulation without waiting for the opinion to be delivered<sup>776</sup>.

The judgment took into account that the observance of this requirement implied that an opinion had to be expressed. In that sense, the mere asking for an opinion is not equivalent to expressing the opinion and, in order to comply with the requirement, it is essential to exhaust all the possibilities to obtain the preliminary opinion<sup>777</sup>. It is the first case where the ECJ clearly qualified the requirement as an essential procedural one. It also stated that a key element is that the opinion has an added value in the procedure, which has to be effectively granted. The mere request of the opinion is not enough to comply with the legal requirement of consultation.

In subsequent cases, many of them introduced by the European Parliament to guarantee its rights emerging from the Treaties, the ECJ appears to confirm this interpretation. In *Parliament v Council*<sup>778</sup>, the ECJ annulled a Council regulation in the area of transports. The annulment was based on the fact that the European Parliament was not consulted a second time in the legislative procedure provided for in Article 75 EC Treaty. This was because the text finally adopted departed substantially from the one on which the institution had already been consulted<sup>779</sup>. The judgment considered the omission of a second consultation to be an infringement of an essential procedural requirement entailing the annulment of the contested measure<sup>780</sup>.

---

<sup>774</sup> The milestone judgment is case *Roquette Frères* but on the same date the Court of Justice also delivered a very similar decision in judgment *Maizena v Council*, Case C-139/79, ECLI:EU:C:1980:250.

<sup>775</sup> *ibid.*, point 33.

<sup>776</sup> *ibid.*, points 5-11.

<sup>777</sup> *ibid.*, points 34-36.

<sup>778</sup> Judgment from the 16th of July 1992, *Parliament v Council*, Case C-65/90, ECLI:EU:C:1992:325.

<sup>779</sup> The importance to consult a second time the European Parliament in case of a altering the substance of a legislative act was already established in previous decisions from the Court of Justice such as judgment from the 15th of July 1970, *Chemiefarma v Commission*, Case C-41/69, ECLI:EU:C:1970:71, points 177-178 or judgment from the 4th of February 1982, *Buyl and Others v Commission*, Case 817/79, ECLI:EU:C:1982:36, points 16-24.

<sup>780</sup> Judgment from the 16th of July 1992, *Parliament v Council*, Case C-65/90, ECLI:EU:C:1992:325, point 21.

Previous decisions from the ECJ<sup>781</sup> have also highlighted the importance to consult a second time the European Parliament in case of a altering the substance of a legislative act. It was recalled in *ACF Chemiefarma v Commission*, or in *Buyl and Others v Commission*. The latter judgment also confirmed, without citing the *Roquette Frères* case-law, that regular consultation with the European Parliament constitutes an essential procedural requirement, the disregard of which renders the regulation in question void. In any case, behind the reasoning on the obligation to consult a second time in case of substantially departing from the original text lies the underlying rationale that a procedural requirement has to provide an added value.

Similar cases delivered by the ECJ<sup>782</sup> have also confirmed the *Roquette Freres* case-law either using the whole reasoning or partially depending on the circumstances of the case. In essence, all these cases have confirmed that the obligation to consult the European Parliament laid down in the Treaties is an essential procedural requirement and failure to do so, either at the outset or as a second time, if the substance of the text is altered, renders the measure in question void, as first held in the *Roquette Frères* judgment.

#### 4.1.2 The obligation to consult the Council and other committees under the European Coal and Steel Community

The ECJ delivered several decisions<sup>783</sup> in the 1950s emphasising the importance to formally consult when primary law required for an opinion from another institution or committee. Under the ECSC Treaty, there was an obligation to consult the Council and the Consultative Committee. In several cases brought by the founding Member States, the ECJ took the opportunity to stress that an official consultation could not take place if it was not formally requested. Any unofficial information supplied to the institution concerned did not meet the requirement. It also underscored that the procedural requirement provided by the Treaty was intended to ensure that the measures concerned were formulated with all due care and prudence, and these procedural requirements might be regarded as essential and, consequently, the question whether they had been observed needed to be examined by the Court even by its own motion<sup>784</sup>.

---

<sup>781</sup> See judgment from the 15th of July 1970, *Chemiefarma v Commission*, Case C-41/69, ECLI:EU:C:1970:71, points 177-178 or judgment from the 4th of February 1982, *Buyl and Others v Commission*, Case 817/79, ECLI:EU:C:1982:36, points 16-24.

<sup>782</sup> See among others judgments from the Court of Justice from the 1st of June 1994, *Parliament v Council*, Case C-388/92, ECLI:EU:C:1994:213, point 19; 10th May 1995, *Parliament v Council*, Case C-417/93, ECLI:EU:C:1995:127, point 9; 5th of July 1995, *Parliament v Council*, Case C-21/94, ECLI:EU:C:1995:220, point 21; 10th of June 1997, *Parliament v Council*, Case C-392/95, ECLI:EU:C:1997:289, point 24.

<sup>783</sup> See judgment from the 21st of December 1954, *France v High Authority*, Case 1-54, ECLI:EU:C:1954:7, p. 15; 21st of December 1954, *Italy v High Authority*, Case 2-54, ECLI:EU:C:1954:8, p. 52.

<sup>784</sup> Judgment from the 21st of December 1955, *Netherlands v High Authority*, Case 6-54, ECLI:EU:C:1955:5, p. 112.

### 4.1.3 The obligation to consult the Economic and Social Committee

The EU judiciary had the opportunity to examine the consequences of not consulting the Economic and Social Committee (ESC). This was highlighted by a series of direct actions brought in 1985 by five Member States (Germany, France, Netherlands, Denmark, and the United Kingdom) on the validity of a Commission's decision to set up a prior communication and consultation procedure on migration policies in relation to third countries. The applicants submitted as a final plea the infringement of essential procedural requirements, in particular, the failure to consult the ESC beforehand. The ECJ examined the nature of the function of the body to be consulted and the objective pursued by the consultation before concluding that failure to consult the ESC should lead to the annulment of the decision<sup>785</sup>.

Firstly, the judgment recalled that the function of the ESC, which is made up of representatives of socio-economic groups, is to advise the Council and Commission on the solutions to be adopted with regard to practical problems of an economic and social nature, and to deliver opinions based on its specific competence and knowledge.

Secondly, the judgment took into account the objective pursued by the article from the Treaty making the consultation compulsory. The decision pointed out that the consultation was mandatory only when the opinion was necessary on substantive questions likely to entail the ESC in making an assessment of a social-economic nature. However, this was not the case when the Commission decided to compile information or organise a meeting, as these were purely preparatory and procedural decisions.

This decision seems to follow the *Roquette frères* case-law from another perspective. To determine whether an essential procedural requirement has been breached, it is important to examine the nature of the EU institution, agency, or body to be consulted as well as the objective pursued by the provision established by primary law. As a consequence, failure to consult does not always imply that the measure adopted is void.

### 4.1.4 The obligation to consult under Article 108(3) TFEU

State aids is an area which has a less clear link with the procedure to adopt legislative measures. Nevertheless, national legislation implementing state aids must be submitted to the Commission for consultation under Article 108(3) TFEU. Some of the decisions taken in this particular area by the EU judiciary enlighten our quest for the possible consequences of national authorities failing to consult the ECB when adopting legislation.

In the *Costa v ENEL* case<sup>786</sup>, the ECJ referred to the obligation to consult. In the first place, the EU judiciary was obliged to construe Article 102 EC Treaty (currently Article

<sup>785</sup> See judgment from the 9th of July 1987, *Germany e.a. v Commission*, Joined cases 281, 283, 284, 285 and 287/85, ECLI:EU:C:1987:351, points 37-38.

<sup>786</sup> Judgment from the 15th of July 1964, *Costa v E.N.E.L.*, Case 6-64, ECLI:EU:C:1964:66, p. 595.

117 TFEU). Additionally, the decision referred to the same obligation to consult under Article 93(3) EC Treaty (currently Article 108(3) TFEU). The ECJ referred to the fact that the Member States limited their freedom to act in the area of States aids by entering into an obligation with the EU, which binds them as states but creates no individual rights, except in the case of the final provision of Article 93(3) EC Treaty which prohibits Member States to put its proposed measures into effect until the procedure pursuant to this Article has resulted in a final decision<sup>787</sup>.

In the *Costa v ENEL* case, the ECJ stated that Article 93(3) EC Treaty conferred rights on individuals which could potentially be used to their advantage in a situation where a piece of legislation had not been submitted to the Commission for consultation. In the *Lorenz* judgment<sup>788</sup>, the EU judiciary took a clearer view on this matter because of the specific circumstances of the case. The judgment recalled that the prohibition on implementation prior to the end of the consultation referred to in the last sentence of Article 93(3) had a direct effect and gave rise to rights in favour of individuals, which national courts were bound to safeguard<sup>789</sup>.

Therefore, Article 108(3) TFEU and the case-law relating to the so-called standstill obligation deriving from this provision is another example of the potential consequences of a consultation obligation. Thus, when the Treaties required to consult an institution to examine the possible effects of a measure to the institution's field of competence, failure to submit the consultation may impact the validity of the measure or, at least, confers specific rights to the subjects affected by the envisaged measures.

#### 4.1.5 The obligation to inform on measures that might affect the internal market under Articles 114 and 117 TFEU

The need to maintain or adopt national legislative measures in certain areas where the EU has adopted harmonising measures to achieve the objectives pursued by the internal market is also subject to a consultation procedure to avoid arbitrary discrimination or a disguised restriction on trade between Member States or to determine whether or not they constitute an obstacle to the functioning of the internal market (Article 114 TFEU) or a distortion of the conditions of competition in the internal market (Article 116 and Article 117 TFEU).

Although these provisions are very specific, the interpretation provided by the ECJ might provide a useful guidance on how to deal with national legislative measures adopted without the ECB consultation when Treaty provisions require such a consultation to be requested.

In fact, in the *Costa v ENEL* case, the ECJ, besides interpreting Article 108(3) TFEU, referred to the obligation to consult provided in the section concerning the approximation of laws. In this case, the EU judiciary was obliged to construe Article

---

<sup>787</sup> *ibid.*

<sup>788</sup> Judgment from the 11th December 1973, *Gebrüder Lorenz GmbH v Federal Republic of Germany and Land Rheinland-Pfalz*, Case 120-73, ECLI:EU:C:1973:152.

<sup>789</sup> *ibid.*, point 8.

102 EC Treaty (currently Article 117 TFEU). Community which binds them as states, but did not create individual rights which national courts must protect<sup>790</sup>.

The judgment declared that this Article was intended to prevent the differences between the legislation of the different Member States with regard to the objectives of the Treaty from becoming more pronounced. By virtue of Article 102 EC Treaty, Member States had limited their freedom of initiative by agreeing to submit to an appropriate procedure of consultation. By binding themselves unambiguously to prior consultation with the Commission in all those cases where their projected legislation might create a risk, however slight, of a possible distortion, the Member States had undertaken an obligation to the EU which binds them as states, but which did not create individual rights that national courts must protect<sup>791</sup>.

Regarding Article 114 TFEU, in a direct action initiated by France, the EU judiciary had to construe the obligation to consult before adopting measures that derogate from harmonised rules. The decision limited itself to recall that it was not possible for a Member State to adopt those rules without prior consultation with the Commission and without confirmation by the Commission<sup>792</sup>.

Similarly, in *Kortas* case the ECJ concluded that the direct effect of a directive, where the deadline for its transposition into national law has expired, is not affected by a notification made by a Member State pursuant to Article 114(4) TFEU, seeking confirmation of provisions of national law derogating from the directive, even where the Commission fails to respond to that notification<sup>793</sup>. The judgment did not address the specific nature of the obligation to consult, but the decision proves again that the procedure to consult a relevant institution is an essential requirement and failure to complete the procedure cannot benefit national authorities.

## 4.2 Obligation to consult under secondary law

After examining the case-law of the ECJ on several obligations to consult under primary law, it is worthy to analyse the approach that the Court has also adopted when some kind of consultation before the adoption of national legislation is required by secondary legislation. In fact, numerous decisions, particularly in the field of technical regulations, have been handed down in recent years which may enlighten the assessment of the legal consequences of failure to comply with this particular procedural requirement.

---

<sup>790</sup> See Judgment from the 15th of July 1964, *Costa v E.N.E.L.*, Case 6-64, ECLI:EU:C:1964:66, p. 595.

<sup>791</sup> *ibid.*

<sup>792</sup> See judgment from the 17th of May 1994, *France v Commission*, Case C-41/93, ECLI:EU:C:1994:196, points 26-30.

<sup>793</sup> See judgment from the 1st of June 1999, *Kortas*, Case C-319/97, ECLI:EU:C:1999:272, point 38.

#### 4.2.1 Directive 75/442 on waste<sup>794</sup>

In a preliminary ruling from 1989<sup>795</sup>, where several producers of plastic containers, wrappings, and bags contested at national level the rules adopted by a Mayor from the Italian town of Cinisello Balsamo, as a second question, the national court asked the ECJ to determine whether Article 3(2) of Directive 75/442 required a Member State to inform the Commission of all draft rules of the kind at issue in the main proceedings before they were definitively adopted. Additionally, the national court wondered if the same article gave individuals a right which they might enforce before the national courts in order to obtain the annulment or suspension of national rules falling within the scope of that provision on the ground that those rules had been adopted without having previously been communicated to the Commission.

In its judgment on the *Enichem Base* case, the Court construed Article 3(2) of Directive 75/442 considering its wording and purpose as not providing derogations or limitations regarding the obligation to inform on any draft rules described in the provision. Consequently, that obligation to consult extended to draft rules drawn up by all authorities in the Member States, including decentralised authorities, such as municipalities.

The most relevant part of the judgment is the consequences that this answer may have as regards the individuals or companies. In answering the third question, the Court examined what the purpose of the communication of the draft rules was. In particular, the judgment noted that the obligation imposed on the Member States by Article 3(2) of Directive 75/442 was intended to ensure that the Commission was informed of any new plans for national measures regarding waste disposal, so that it could consider whether Community harmonising legislation is called for and whether the draft rules submitted to it were compatible with EU law, taking appropriate measures if necessary. By contrast, neither the wording nor the purpose of that same provision provided any support for the view that failure by the Member States to observe their obligation to give prior notice rendered in itself unlawful the rules thus adopted. On this basis, the judgment concluded that Article 3(2) of Directive 75/442 did not give rise to any right for individuals which might be infringed by a Member State's breach of its obligation to inform the Commission in advance of draft rules. Consequently, no right could be enforced before a national court.

The opinion of Advocate General Jacobs<sup>796</sup> is useful to understand the reply from the ECJ. In fact, in points 14 and 15 of his opinion, the Advocate General found useful to make a comparison between Directive 75/442 and Directive 83/189 on technical regulations. In fact, the former Directive contained detailed provisions for the Commission and the Member States to comment on the draft rules, requiring the Member State proposing the draft rules to postpone its adoption. This element is key to conclude that in the absence of such procedure, it could not be maintained that a failure to inform the Commission had the effect to render the measures unlawful.

---

<sup>794</sup> Council Directives 75/442 of 15 July 1975 on waste (OJ L 194, 25.7.1975, p. 39).

<sup>795</sup> See judgment from 13th of July 1989, *Enichem Base and Others v Comune di Cinisello Balsamo*, Case 380/87, ECLI:EU:C:1989:318.

<sup>796</sup> See opinion of Advocate General Jacobs delivered on the 6th of March 1989 in case *Enichem Base and others v Comune di Cinisello Balsamo*, Case 380/87, ECLI:EU:C:1989:135, points 14-15 and 17.

Similarly, the procedure provided by Directive 75/442 could not be assimilated to that provided by Article 108(3) TFEU, as argued by one of the parties, as the State aid rules did establish a specific procedure where the Commission had its say in concluding whether a State aid was involved and its eventual compatibility with EU law.

The ECJ confirmed this interpretation in an earlier judgment in which the *Enichem Base* case was compared to the circumstances relevant to the case-law on the technical regulations Directive. In the *Sapod Audic* case<sup>797</sup>, the Court noted that the conclusion deriving from *Enichem Base* was based on the idea that this was an information procedure which did not provide for any procedure for monitoring the draft rules or make the implementation of the planned rules subject to the Commission's agreement<sup>798</sup>.

In conclusion, the case-law relating to Directive 75/442 highlights the importance of examining the wording and the purpose of the procedure requiring the communication of draft rules before concluding on the possible legal consequences of failure to comply with the procedure laid down by a provision of secondary law. Indeed, the decision seems to confirm that for an individual, such as the plastic producers, in order to be able to ask the national judge not to apply national legislation that is not in compliance with the requirement to consult, a key element is to identify the objective pursued by the procedure. If it is simply a matter of informing the body concerned, the requirement must not be qualified as an essential procedural requirement.

#### 4.2.2 Directive 80/987 on the protection of employees in the event of insolvency<sup>799</sup>

In the framework of this Directive, the ECJ confirmed that the wording and the purpose of the provision requiring the communication of a draft rule are essential in determining whether any rights are conferred on a particular subject or whether the draft rules adopted without complying with this requirement may be considered non-applicable.

Firstly, the decision pointed out that the second subparagraph of Article 4(3) of the Directive 80/987 requires Member States which have set a ceiling to the liability for employees' outstanding claims, as the preceding subparagraph authorises them to do, to inform the Commission of the methods used to set that ceiling. Nevertheless, the judgment indicated that the duty to inform does not give rise to a procedure for monitoring the methods used by the Member State. In addition, the Member State's exercise of the option provided by the Directive to establish a ceiling was not subject to an express or implied approval from the Commission. Referring to the *Enichem Base* case, the ECJ conceded that the wording and the purpose of the provision did not render the draft rules adopted without informing the Commission unlawful.

---

<sup>797</sup> Judgment from the 6th of June 2002, *Sapod Audic v Eco-Emballages SA*, Case C-159/00, ECLI:EU:C:2002:343.

<sup>798</sup> *ibid*, point 60.

<sup>799</sup> Council Directive 80/987/EEC of 20 October 1980 on the approximation of the laws of the Member States relating to the protection of employees in the event of the insolvency of their employer (OJ 1980 L 283, p. 23).



Consequently, the obligation to give notice was simply to inform the Commission. On this basis, the Court found that Directive 80/987 did not preclude the application of a national legislation, where the Member State in question had not informed the Commission of the methods used to establish a ceiling in specific draft rules<sup>800</sup>.

Therefore, this decision also confirms the importance of the nature and purpose of the provisions to conclude whether the failure to communicate certain draft rules precludes the application of those finally adopted by the Member State.

#### 4.2.3 Sixth VAT Council Directive<sup>801</sup>

In the field of the VAT, the Court had the opportunity to examine the legal consequences of failure to comply with the obligation to notify national rules which proposed to derogate from the scheme established by the Directive.

In the *Direct Cosmetics* case<sup>802</sup>, the ECJ in a fairly straightforward reasoning held that a Member State's tax authority could not rely, against a taxable person, on a provision derogating from the scheme of the directive and enacted in breach of the duty of notification imposed on Member States by Article 27(2) of the Sixth Directive without disregarding the obligation incumbent on that Member State's under Article 288 TFEU. The decision did not rely on the classical argumentation of the existence of an essential procedural requirement in the context of a monitoring or approval procedure but rather on the wording of the provision and the fact that a harmonised scheme existed.

#### 4.2.4 Case-law on the field of technical regulations, in particular, Directive 83/189/EC<sup>803</sup>, Directive 98/34/EC<sup>804</sup> or Directive 2015/1535<sup>805</sup>

There is a consistent line of cases decided by the ECJ in the field of the technical regulations which are particularly useful to understand the scope, purpose, and possible legal consequences of failing to comply with an essential procedural requirement. In fact, this settled case-law started with the interpretation of Directive

---

<sup>800</sup> See judgment from the 16th of July 1998, *Dumon and Froment*, Case C-235/95, ECLI:EU:C:1998:365, points 28-33.

<sup>801</sup> Sixth Council Directive (No 77/388/EEC) of 17 May 1977 on the harmonization of the laws of the Member States relating to turnover taxes — Common system of value-added tax: uniform basis of assessment (OJ 1977 L 145, p. 1).

<sup>802</sup> See judgment from the 13th of February 1985, *Direct Cosmetics*, Case 5/84, ECLI:EU:C:1985:71, points 36-38.

<sup>803</sup> Council Directive 83/189/EEC of 28 March 1983 laying down a procedure for the provision of information in the field of technical standards and regulations (OJ 1983 L 109, p. 8)

<sup>804</sup> Directive 98/34/EC of the European Parliament and of the Council of 22 June 1998 laying down a procedure for the provision of information in the field of technical standards and regulations and of rules on Information Society services (OJ 1998 L 204, p. 37)

<sup>805</sup> Directive (EU) 2015/1535 of the European Parliament and of the Council of 9 September 2015 laying down a procedure for the provision of information in the field of technical regulations and of rules on Information Society services (OJ 2015 L 241, p. 1), which repealed and replaced Directive 98/34 as of 7 October 2015.

83/189/EC and followed by cases concerning the subsequent directives repealing and replacing the previous one, like Directive 98/34/EC and Directive 2015/1535<sup>806</sup>.

It is worth mentioning that the documents of the ECB on the obligation to consult this institution by national authorities regarding draft legislative provisions relies substantially on this line of cases to substantiate that a national provision adopted in breach of an essential procedural requirement is unenforceable against individuals<sup>807</sup>. Therefore, it is important to understand this line of reasoning from the ECJ. Taking into consideration that an important number of decisions have been adopted on preliminary rulings regarding the three consecutive Directives<sup>808</sup>, the analysis will be limited to a selection of the cases that might bring relevant insights for this chapter.

#### 4.2.4.1 No notification of the measures adopted by the national authorities or adoption before the end of the standstill period

The Directives on technical regulations establish an obligation to notify to the Commission any draft national measure relating to a technical regulation that may affect the freedom of movement of goods within the internal market during a period set up by the Directives (period of suspension or stand still period). Member States cannot adopt the final measures, and before approval there is a certain period of time where they may receive comments on the draft national measure from the Commission or other Member States.

The notification and the standstill period therefore allow the Commission and the other Member States to examine whether the draft measures in question create barriers to trade contrary to the TFEU or obstacles which are to be avoided by the adoption of common or harmonised measures and to propose amendments to the envisaged national measures. This procedure also enables the Commission to propose or adopt EU rules on the matter covered by the envisaged measure<sup>809</sup>.

Taking into consideration this purpose, in the leading case *CIA International Security*, the Grand Chamber of the ECJ concluded that the obligation to notify and to respect the period of suspension laid down in Articles 8 and 9 of Directive 83/189 had a direct

---

<sup>806</sup> Several doctrinal contributions refer to the specific question of the consequences to failure to consult under these Directives or assess the scope of the leading cases on this area. See Engsig Sørensen K. (2012), "Technical regulations and their notification", in Gaines, S., Olsen, B.E. and Engsig Sørensen K. (eds.), *Liberalising trade in the EU and the WTO*, Cambridge University Press, United Kingdom, pp. 261-287; Sheehan E. (2021), "The Case-law of the Court of Justice of the European Union on Directive 98/34/EC Laying Down a Procedure for the Provision of Information in the Field of Technical Standards and Regulations (Directive 2015/1535) and Its Impact on Private Law Relations", in Tridimas T. and Durovic, M. (eds.), *New Directions in European Private Law*, Hart Publishing, Oxford, pp. 103-126 and Slot P.J. (1996), "Case C-194/94, *CIA Security International SA v. Signalson SA*", *Common Market Law Review*, No 5, pp. 1035-1050.

<sup>807</sup> European Central Bank (2015), *Guide to consultation of the European Central Bank by national authorities regarding draft legislative provisions*, Frankfurt am Main, October, p. 27.

<sup>808</sup> An interesting document can be found on the Commission's website on the technical regulation information system (TRIS). The document case-law relating to Directive (EU) 2015/1535 refers to an important number of decision taking by the Court of Justice and can be consulted in <https://technical-regulation-information-system.ec.europa.eu/en/home> (last consultation 24th August 2023).

<sup>809</sup> See judgment from 30th of April 1996, *CIA Security International*, Case C-194/94, ECLI:EU:C:1996:172, point 41.

effect. Consequently, as these articles were unconditional and sufficiently precise as to their content, they might be invoked on by individuals before national courts<sup>810</sup>.

Under these circumstances, the Court had also the obligation to answer to the Belgian court which had referred the question for a preliminary ruling on the legal consequences to be drawn from a breach by a Member State of its obligation to notify. In particular, the Court was called to clarify whether EU law should be interpreted as meaning that a breach of the obligation to notify, constituting a procedural defect in the adoption of the technical regulations concerned, rendered such technical regulations inapplicable so that they might not be enforced against individuals.

Once again, the Court examined the wording and the purpose of the Directive. With regards to the wording, the decision stated that it was unnecessary for the Directive to lay down an express provision declaring the non-notified national regulation inapplicable. The ECJ pointed out that the aim of the Directive was to protect freedom of movement for goods by means of preventive control and that the obligation to notify was essential for achieving such control. The decision also referred to the 'effet utile' principle, and recalled that the effectiveness of the control will be that much greater if the directive was interpreted as meaning that a breach of the obligation to notify constituted a substantial procedural defect of such a kind as to render the technical regulations in question inapplicable to individuals<sup>811</sup>.

Additional arguments in support of the conclusion were to distinguish this interpretation from previous case-law, such as the *Enichem Base* case mentioned-above, and disregard the arguments of the intervening Member States. Regarding the former reasoning, it is important to highlight that the ECJ emphasised that the wording and purpose of the provisions are essential in differentiating an obligation to inform from an obligation to notify in the framework of a European supervisory procedure where action or opinion may be expected from the Commission or other Member States<sup>812</sup>.

This conclusion is well-established it as has been reiterated in an large number of subsequent decisions<sup>813</sup>.

After the *CIA Security International* case, the ECJ clarified the scope and the effects of the unenforceability of any technical regulation which have not been notified by the national authorities following the procedure laid down in the three Directives.

---

<sup>810</sup> *ibid.*, point 44.

<sup>811</sup> *ibid.*, point 48.

<sup>812</sup> *ibid.*, points 49-50.

<sup>813</sup> See among others, judgments of 16th of June 1998, *Lemmens*, Case C-226/97, ECLI:EU:C:1998:296, point 33; 26th of September 2000, *Unilever*, Case C-443/98, ECLI:EU:C:2000:496, point 44; 6 June 2002, *Sapod Audic*, Case C-159/00, ECLI:EU:C:2002:343, point 49; 8th of September 2005, *Lidl Italia*, Case C-303/04, ECLI:EU:C:2005:5283, point 23; 1st of January 2013, *Belgische Petroleum Unie and Others*, Case C-26/11, ECLI:EU:C:2013:44, point 50; 10th of July 2014, *Ivansson and Others*, Case C-307/13, ECLI:EU:C:2014:2058, point 48; 11th of June 2015, *Berlington Hungary and Others*, Case C-98/14, ECLI:EU:C:2015:386, point 108; 16 July 2015, *UNIC and Uni.co.pel*, Case C-95/14, ECLI:EU:C:2015:492, points 29-30; 2nd of February 2016, *Ince*, Case C-336/14, ECLI:EU:C:2016:72, point 67; 1st of February 2017, *Municipio de Palmela*, Case C-144/16, ECLI:EU:C:2017:76, point 36; 12 September 2019, *VG Media*, Case C-299/17, ECLI:EU:C:2019:716, point 39 and order of 21 April 2016, *Beca Engineering*, Case C-285/15, ECLI:EU:C:2016:295, point 37.

In the *Lemmens* case<sup>814</sup>, the ECJ held that the breach of the notification obligation does not have the effect of preventing evidence obtained by means of a breath-analysis device, authorised in accordance with regulations which have not been notified, to be relied upon against an individual charged with driving while under the influence of alcohol.

The case-law clarified which elements from the draft national measures are affected by the unenforceability. In the *Ince* case<sup>815</sup>, the ECJ stated that the non-applicability resulting from a breach of the obligation to notify a law adopted by a Member State and containing technical regulations does not extend to all the provisions of such a law, but only to the specific technical rules it contained. This conclusion is based on the text of the Directive which requires the whole draft law containing technical rules to be communicated to the Commission but not all the provisions of the law.

There are also formal aspects that affect the obligation to notify a draft measure. For instance, case-law has ruled that a new draft technical regulation, the content of which may be identical to that of a previous draft notified under the same procedure may be subject to a new communication if the temporal and territorial scope is modified<sup>816</sup>. Similarly, in a Swedish preliminary ruling the ECJ was invited to interpret when a new communication is compulsory for the national authorities in the event of a significant change in the draft measures during the period of suspension. In this regard, the EU judiciary clarified that significant changes included any situation referred in a precise article of the Directive but also the shortening of the timetable for implementation of the technical regulation<sup>817</sup>. Additionally, failure to comply with a standstill period constituted also a substantial procedural defect rendering the technical regulation at issue also inapplicable and unenforceable against individuals<sup>818</sup>.

#### 4.2.4.2 The infringement of the obligation to notify the draft national measures under the Directives on technical regulations

In view of the obligation created by Directive 83/189 and subsequent directives, the Commission regularly brought infringement proceedings before the ECJ on the grounds that the national authorities had failed to communicate the draft national measures that were to be regarded as technical regulations. In several cases, the ECJ

---

<sup>814</sup> See judgment of 16th of June 1998, *Lemmens*, Case C-226/97, ECLI:EU:C:1998:296, point 37.

<sup>815</sup> See judgment 2nd of February 2016, *Ince*, Case C-336/14, ECLI:EU:C:2016:72, point 68 and also the judgment from 1st of February 2017, *Município de Palmela*, Case C-144/16, ECLI:EU:C:2017:76, points 35-38.

<sup>816</sup> See judgment 2nd of February 2016, *Ince*, Case C-336/14, ECLI:EU:C:2016:72, points 81 and 82.

<sup>817</sup> See judgment 10th of July 2014, *Ivansson and Others*, Case C-307/13, ECLI:EU:C:2014:2058, points 44-45.

<sup>818</sup> See 16 July 2015, *UNIC and Uni.co.pei*, Case C-95/14, ECLI:EU:C:2015:492, points 29-30.

concluded that the Member States had infringed EU law in the framework of the procedure provided for in Article 258 TFEU<sup>819</sup>.

#### 4.2.5 Directive 2000/31/EC on information society services<sup>820</sup>

In a more recent and relevant case decided by the Grand Chamber of the ECJ, the Court confirmed the common thread that seemed to emerge from the case-law on the technical regulations Directives. This thread now seems to emphasise that it is essential to distinguish the purpose of the procedure which obliges a Member State to communicate certain draft rules in a specific area of EU law to conclude that the breach of the obligation to consult should result in precluding the application of the national rules in a specific situation.

In the *Airbnb Ireland* case,<sup>821</sup> Airbnb was accused of having managed monies for activities relating to the mediation and management of buildings and businesses with no professional licence, contrary to the French law, for almost five years. In the context of the national proceedings, an investigating judge of the *Tribunal de Grande Instance de Paris* (Regional Court, Paris) wondered whether the service provided by Airbnb Ireland should be classified as an 'information society service' within the meaning of that Directive and, if so, whether that precludes the French law from being applied to that company in the main proceedings or, on the contrary, whether that Directive did not preclude criminal proceedings being brought against Airbnb Ireland on the basis of that law. In those circumstances, the national court referred several questions to the ECJ<sup>822</sup>.

In the answer to the second question, the ECJ clarified for the first time that the fact that the national law was adopted before the EU law requiring consultation on certain draft rules likely to affect an information society service provider does not relieve a Member State from complying with the requirement. In that sense, the fact that the EU legislature did not provide for a derogation authorising Member States to maintain measures predating that directive, and which could restrict the freedom to provide information society services without complying with the conditions laid down for that

---

<sup>819</sup> See judgments from the 2nd of August 1993, *Commission v Italy*, Case C-139/92, ECLI:EU:C:1993:346; of 14th of July 1994, *Commission v Netherlands*, Case C-52/93, ECLI:EU:C:1994:301; 14th of July 1994, *Commission v Netherlands*, Case C-61/93, ECLI:EU:C:1994:302; 8th of September 2005, *Commission v Portugal*, Case C-500/03, ECLI:EU:C:2005:515; 26th of October 2006, *Commission v Greece*, Case C-65/05, ECLI:EU:C:2006:673, point 66. In a judgment from the 4th of June 2009, *Commission v Greece*, Case C-109/08, ECLI:EU:C:2009:346, the Greek authorities were found in breach of Article 228 TEC (currently article 260 TFEU) by not amending the law that was not notified under Directive 98/34/EC and the Court of Justice imposed a penalty payment of EUR 31 536 for each day of delay in implementing the measures necessary to comply with the judgment in Case C-65/05 and a lump sum of 3 million euros.

<sup>820</sup> Directive 2000/31/EC of the European Parliament and of the Council of 8 June 2000 on certain legal aspects of information society services, in particular electronic commerce, in the Internal Market (OJ 2000 L 178, p. 1).

<sup>821</sup> See judgment from the 19th of December 2019, *Airbnb Ireland*, Case C-390/18, ECLI:EU:C:2019:1112.

<sup>822</sup> See Fedele G. (2020), "Sugli effetti della violazione di obblighi procedurali sostanziali: in margine alla sentenza Airbnb", *European Papers*, pp. 433-446 and Van Cleynenbreugel, P. (2020), "Accommodating the Freedom of Online Platforms to Provide Services through the Incidental Direct Effect Back Door: Airbnb Ireland", *Common Market Law Review*, No 4, pp. 1201-1228.

purpose by that directive, does not relieve the national authorities from the obligation to consult the rules<sup>823</sup>.

Relying on this arguments, the Grand Chamber concluded that a Member State's failure to fulfil its obligation to notify a measure restricting the freedom to provide an information society service provided by an operator established on the territory of another Member State, as laid down in the second indent of Article 3(4)(b) of Directive 2000/31, renders the measure unenforceable against individuals, thus applying by analogy the judgment of 30 April 1996 in case *CIA Security International*.

Therefore, the ECJ assessed whether a Member State's failure to fulfil its obligation to give prior notification of the measures restricting the freedom to provide information society services originating in another Member State, as laid down in the second indent of Article 3(4)(b) of Directive 2000/31, rendered the legislation concerned unenforceable against individuals, in the same way as a Member State's failure to fulfil its obligation to give prior notification of the technical rules, as laid down in Article 5(1) of Directive 2015/1535.

This judgment takes into account the content and the purpose of the obligation laid down in that provision establishing the obligation to communicate any rules that may affect the freedom to provide information society services between Member States. Directive 2000/31 gives the Commission the power to examine the compatibility with EU law of any national measure notified. Under this procedure, the Commission can avoid the adoption or at least the maintenance of obstacles to trade contrary to the TFEU, in particular by proposing amendments to be made to the national measures concerned. The fact that Directive 2000/31 does not formally provide for a standstill clause is not an obstacle to the application of the case-law on technical regulations, since there is a clear obligation to give prior notification to the Commission and to the Member States, on whose territory the service provider in question is established, of the intention to adopt such a measure.

Based on those arguments, the Grand Chamber concluded that it was possible to extend to Directive 2000/31 the solution adopted by the ECJ in the field of technical regulations (*CIA Security International* case). Firstly, because once again the provisions of the Directive established not only an obligation to provide information, as in the *Enichem Base* case, but an essential procedural requirement in the context of a monitoring or control procedure. More precisely, in point 95 of the decision, the ECJ explained why the unenforceability of a non-notified measure was justified in this particular case, since the purpose of the notification obligation was not to prevent a Member State from adopting measures falling within its own sphere of competence and which could affect the freedom to provide services, but to prevent a Member State from impinging, as a matter of principle, on the competence of the Member State in which the information society services provider in question is established<sup>824</sup>.

The ECJ justification on this point is an additional and important development in relation to previous rulings, as it emphasises that if the objective behind the notification

---

<sup>823</sup> See judgment from the 19th of December 2019, *Airbnb Ireland*, Case C-390/18, ECLI:EU:C:2019:1112, point 87.

<sup>824</sup> *ibid.*, points 89-95.

obligation is to prevent a national measure from impinging or preventing another Member State (or perhaps another institution) from exercising its own competence, this might justify the unenforceability of the national measure in the event of non-compliance with the procedure.

## 5 The potential unenforceability of the legislation lacking the consult of the ECB

The analysis of the ECJ's case-law on the obligation to notify and consult on draft measures, either by the EU institution or by national authorities, seems to confirm the position expressed by Advocate General Jacobs in the *OLAF* case<sup>825</sup>.

Indeed, in his opinion the Advocate General highlighted that none of the parties in the proceedings contested that the consultation of the ECB on measures affecting its field of competence was an essential procedural requirement<sup>826</sup>. As recalled in part 3, the ECJ did not conclude clearly on this matter. Nevertheless, the case-law examined in the previous part seems to reinforce the Advocate General's view and consider that the consultation of the ECB might be an essential procedural requirement when the measures fall within the fields of competence of the institution. Confirmation of this premise is a relevant element for the eventual development of the argument that the non-compliant EU norm is invalid or that the non-compliant national legislation is unenforceable either in proceedings, between an individual or company and a public authority, or between individuals.

In the first place, it is essential to identify the objective of the provisions requiring the communication of the EU or national draft measures. The case-law seems to distinguish two situations. Firstly, there is the situation where the notification obligation is linked to a mere information procedure as it results from Directive 75/442 and Directive 80/987. Secondly, there are other situations where the notification obligation is part of a monitoring procedure or an EU procedure where a decision or an opinion of an EU institution, or other Member States, is expected in order to be considered in the adoption of the measures. The case-law relating to Article 108(3) TFEU, Article 114 TFEU and Article 117 TFEU, as well as legislative procedures which require the consultation of the European Parliament or those requiring consultation of the ESC or the Council to show that the need to ensure the participation of those actors has characterised the requirement of consultation as an essential procedural requirement. The same can be inferred even more clearly from the settled case-law in relation to the Directives on technical regulations.

In the second place, it is also relevant to establish whether the procedural rules applicable to the consultation provide for a period of suspension or standstill period. However, the recent judgment on the *Airbnb Ireland* case shows that it is not essential

---

<sup>825</sup> Opinion of Advocate General Jacobs delivered on the 3rd of October 2002, Case C-11/00, *Commission v ECB*, ECLI:EU:C:2002:556, point 131.

<sup>826</sup> *ibid.*

that the wording of the provisions requires a period of suspension to conclude on the unenforceability of the non-complying measures.

In the third place, the context of the provision is also an element to be taken into account. In particular, the fact that the legal basis requiring a consultation establishes an authorisation procedure or provides that the institution, agency, or body consulted is expected to take some kind of action is an element that may be decisive in characterising the condition as an essential procedural requirement. Indeed, both the case-law on the consultation of the European Parliament and on technical regulations seems to support the interpretation that the requirement must be fulfilled not only formally but also substantially. As the ECJ stated in the *Roquette Frères* case, the mere request for an opinion is not equivalent to the expression of that opinion and, in order to comply with this requirement, it is essential to exhaust all the possibilities to obtain the preliminary opinion.

As regards the application of these three elements to the obligation to consult the ECB, laid down in the framework described in part 2, a number of observations should be made.

First, it seems clear from the wording and the purpose of both the provisions of the TFEU and the ESCB's Protocol that the consultation of the ECB on any proposed EU act or draft national provision in its fields of competence is not a mere information procedure. Second, the wording is similar to other provisions of primary law requiring the consultation of the European Parliament. In addition, the reference to "its fields of competence" is another element that seems to indicate that the drafters wanted to ensure that the adoption of new EU acts or national legislative measures does not affect, in particular, the exclusive competence of the EU in the field of monetary policy, its independence as well as any additional competences conferred to the ECB. The use of the plural as opposed to the singular also confirms that other areas might be affected apart from the monetary policy. In fact, in the *OLAF* case, the ECJ considered it as a key element to disregard the ECB's argument that there was an obligation to consult the ECB because the area of the contested EU act was an area in which the ECB had not been assigned any specific tasks<sup>827</sup>.

Moreover, the Council Decision 98/415/EC establishing a formal procedure for consultation of the ECB mentioned in part 2 may be regarded as containing a requirement similar to a period of suspension or standstill period mirroring what is established in other areas of EU law such as the Directives on technical regulations. Indeed, Article 4 of the Council Decision 98/415/EC requires that Member States to take the necessary measures to ensure effective compliance with the decision. In particular, Member States shall ensure that the ECB is consulted at an appropriate stage to enable the authority initiating the draft legislative provision to take into consideration the ECB's opinion before taking its decision on the substance and that the opinion received from the ECB is brought to the knowledge of the adopting authority. It appears that the reasoning which led the ECJ to declare unenforceable the non-notified legislation in the areas identified in part 3 could be applied into cases

---

<sup>827</sup> See judgment from the 10th of July 2003, *Commission v ECB*, Case C-11/00, ECLI:EU:C:2003:395, point 111.



of infringement of Article 127(4) TFEU and the Council decision to ensure the 'effet utile' of this procedural requirement.

In conclusion, the analysis of the case-law described in the previous part may be seen as confirming the statement made by the Advocate General in his opinion in the *OLAF* case, which could be further substantiated by the case-law of the ECJ as well as other elements of primary law and the Council Decision 98/415/EC. It also seems to confirm the legal arguments as set out in section 6 of the ECB guide on the consultation of the ECB by national authorities regarding draft legislative provisions from 2015. Nevertheless, the ECJ will have the last word in the context of one of the legal remedies in the event of non-compliance with this consultation.

An additional conclusion from the previous premise is that the case-law concerning the obligation to consult the European Parliament or the Commission under the Directives on technical regulations mentioned in part 2 could be applied. Under this condition, it would be possible to argue in different situations the unenforceability of the EU acts or national legislative provisions that do not comply with the consultation procedure following the conclusions of the Court in the *CIA International Security* case or the most recent *Airbnb Ireland* case. In doing so, it is also important to take into consideration the existing remedies laid down by the Treaties.

## 6 Legal remedies

The Treaties have established a set of legal remedies which constitute a complete and coherent system of actions. In the event of a breach of the obligation to consult the ECB, it is possible to envisage the use of various legal procedures provided for in the Treaties.

Taking into consideration that the obligation to consult may affect the EU legislature, as it is the one adopting the measures referred to in Article 127(4) TFEU, or national authorities, the legal remedies laid down in the Treaties are different.

In the first place, if an institution such as the Commission, the Council and/or the European Parliament should be liable for failing to consult the ECB in a situation where this condition could be qualified as an essential procedural requirement, the Treaties provide for the action for annulment established in Article 263 TFEU. It is interesting to note that an essential element determining judicial review from the ECJ is that the EU act should affect the ECB's fields of competence<sup>828</sup>.

Three additional remarks may be added. As regards the subject matter, only a few authors<sup>829</sup> have argued that the obligation to consult only affects legislative acts and excludes delegated and implementing acts. However, neither Article 127(4) TFEU nor Article 4 of the ESCB's Protocol distinguish between these types of EU acts. In addition, an examination of the database on the consultations submitted to the ECB shows that many draft delegated acts (particularly based on Article 290 TFEU) or draft

<sup>828</sup> *ibid.*

<sup>829</sup> Flynn L. (2019), "Article 127 TFEU", in Kellerbauer M., Klamert M., and Tomkin J. (eds), *The EU Treaties and the Charter of Fundamental Rights: A Commentary*, Oxford University Press, Oxford, p. 1302.

implementing acts (Article 291 TFEU) have been submitted to the institution<sup>830</sup>. As regards the competent jurisdiction, the normal rules on the allocation of cases between the ECJ and the General Court apply. Finally, it is important to highlight that the possibility of invoking the failure to consult the ECB in an action for annulment brought by a person or a company is subject to the prior condition of having the *locus standi* required by Article 263 TFEU as developed by the case-law of the EU Courts.

In the second place, where the obligation to consult is imposed on a national authority, infringement procedures may be initiated by the Commission (Article 258 TFEU) or, more exceptionally by another Member State (Article 259 TFEU). The Treaties provide for a system of enforcement of the judgments of the ECJ in the event of a failure to comply with a judicial decision declaring the breach by a national authority of provisions of the Treaties or of the Council Decision 98/415/EC. An additional infringement proceedings may be initiated which may also result in a judgment of the ECJ imposing a penalty payment and/or a lump sum. The case-law referred to in part 4 on the infringements by Member States of the obligation to consult deriving from the Directives on technical regulations is an example of the use of these legal remedies.

Eventually, since the national authority is a national central bank which is required to consult the ECB, the Treaties also provide that the ECB may initiate by its own motion, according to Article 271(d) TFEU, in order to obtain a decision on the existence of an infringement of EU law. Indeed, national central banks have the powers to adopt legislative or regulatory measures that may affect the ECB's fields of competence. Nevertheless, this is a legal remedy which has not been used until now.

In the third place, it cannot be ignored that the failure to consult the ECB may be invoked in a plea of illegality (Article 277 TFEU) in an action for annulment against of a specific decision applying an EU act adopted in a breach of an essential procedural requirement. This was the legal remedy chosen by the ECB in its defence when the Commission challenged the legality of the ECB's Decision of 7<sup>th</sup> of October 1999<sup>831</sup>.

Recent development in the area of the Banking Union may raise additional legal and difficult questions. These relate to how the ECB should react in a situation where under EU law it is obliged to apply national legislation, but this legislation has been adopted without complying with the consultation procedure to the ECB.

In the fourth place, an indirect legal remedy to control the legality of EU acts but also indirectly of national legislative provisions that does not comply with the consultation procedure would be the preliminary ruling (Article 267 TFEU) on the validity of the EU acts or on the consequences that may be drawn from EU law for national legislation that is in breach of the former. This legal remedy could become the most common

---

<sup>830</sup> See for example Opinion of the European Central Bank of 27 November 2012 on various draft regulatory and implementing technical standards submitted by the European Securities and Markets Authority to the Commission to be adopted by means of Commission delegated and implementing regulations supplementing Regulation (EU) No 648/2012 of the European Parliament and of the Council on OTC derivatives, central counterparties and trade repositories (CON/2012/95) (OJ C 60, 1.3.2013, p. 1); Opinion of the European Central Bank of 24 May 2012 on a draft Commission delegated regulation supplementing Directive 2011/61/EU of the European Parliament and of the Council with regard to exemptions, general operating conditions, depositaries, leverage, transparency and supervision (CON/2012/42) (OJ C 47, 19.2.2013, p. 1).

<sup>831</sup> See judgment from the 10th of July 2003, *Commission v ECB*, Case C-11/00, ECLI:EU:C:2003:395, points 106-112.

procedure for challenging non-compliant national measures as demonstrated by established case-law on the technical regulations Directives. Potentially, any recipient of decisions applying national legislation that may affect the ECB's field of competence could challenge them arguing that EU law prevents this legislation from being enforced in the particular case at hand.

In the fifth place, the legal remedies laid down in the Treaties include an action for compensation for the damage caused by the institutions' failure to fulfil their obligations provided that conditions laid down in Article 268 TFEU are met. It should be noted that this legal remedy has already been used at national level in cases of non-compliance with the obligation to consult the Commission and the Member States under the technical regulations Directives. The ECJ concluded that the provisions of Directive 98/34 were not intended to confer rights on individuals, in such a way that their infringement by a Member State gives rise to a right for individuals to obtain compensation from the Member State for the damage suffered as a result of that infringement on the basis of EU law<sup>832</sup>. Apart from the precedents mentioned in part 3, there are no precedents of action for damages in this area.

Finally, even though examples in which interim measures may be granted in the context of a direct action, in particular an action for annulment or an action for failure to fulfil an obligation, are rare, it should be recalled that applying to the EU judicature to obtain such measures is still a possibility, provided that the conditions set out in the case-law on Article 279 TFEU are met.

## 7 Conclusions

In a context in which the EU legislature has conferred additional powers on the ECB and extending its fields of competence, it is quite important to understand the scope and nature of the obligation to consult the ECB provided by the Treaties prior to the adoption of EU acts or national legislative provisions in areas which the ECB has been entrusted with specific tasks.

The purpose of this chapter is to provide a general overview of the nature of the Treaties requirement to consult the ECB in its fields of competence and to answer the Shakespearian question on the legal consequences to consult or not to consult. To this end, it is important to recall the framework deriving from Article 127(4) TFEU, the ESCB's Protocol, and Council Decision 98/415/EC establishing specific rules on the consultation of the ECB. In order to conclude on the nature of this requirement it has been useful to examine the case-law of the ECJ in various areas where there is an obligation to inform or to consult an institution, agency, or body before adopting a normative act. The established case-law in some areas, in particular the obligation to consult the European Parliament or the Commission and the Member States before adopting a technical regulations, seems to demonstrate that – by analogy – failure to comply with the obligation to consult the ECB may be characterised as a breach of an essential procedural requirement. This premise could lead to a valid legal argument

---

<sup>832</sup> See judgment of 11th June 2015, *Berlington Hungary and Others*, Case C-98/14, ECLI:EU:C:2015:386, points 107-110.

that EU acts adopted in breach of this condition might be invalid, and that non-compliant national measures might be unenforceable in a particular case.

Qualifying the failure to notify all these draft measures to the ECB as an essential procedural requirement and considering the need to ensure the 'effet utile' of this consultation may lead to the application of the case-law on the legal consequences of this failure. In particular, this may lead to the existence of a problem of validity of a EU act or a problem of enforceability of a national legislative provisions through the legal remedies provided by the Treaties or before national judges. The examination of the current doctrinal literature<sup>833</sup> has also confirmed these conclusions since not a single opinion disputes this reasoning.

So far, with the exception of the *OLAF* case, the ECJ or the General Court have not been confronted with a situation in which some of the questions arising from this contribution have been raised. The increasing allocation of new specific tasks to the ECB and the extension of its fields of competence, notably, in the Banking Union increases the chances for the EU judiciary to answer these questions. It is probably only a matter of time before the ECJ has its next say in this challenging area.

---

<sup>833</sup> Arda A., (2004) "Consulting the European Central Bank : legal aspects of the Community and national authorities' obligation to consult the ECB pursuant to Article 105(4) EC", *Euredia*, pp. 111-152; Lambrinoc, S.E. Elena (2009), "The legal duty to consult the European Central Bank national and EU consultations", Legal Working Paper Series No 9, ECB, Frankfurt am Main, November; Posiūnas G. (2011/6), "Consulting the European Central Bank in the Regulatory Field of the National Central Bank of the Member State of the European Union", *European Business Law Review*, pp. 815-846; Würtz K. (2005), "The legal framework applicable to ECB consultations on proposed Community acts ", *Euredia*, No 4, pp. 283-327.



## Part VII

### Preliminary rulings: the past, the present and the future

# Preliminary rulings – the past, the present and the future: an introduction

Frank Elderson\*

## 1 Introduction

The topic of this panel discussion stands at the very core of European Union (EU) law. The preliminary reference procedure is the tool that allows national courts to address questions on EU law to the Court of Justice of the European Union (CJEU). The preliminary reference procedure enables the CJEU to provide direction to national courts on the proper understanding of EU law. The preliminary reference procedure also enables the CJEU to ensure the uniform application of EU law and thereby to preserve the cohesion and efficacy of the EU legal framework.<sup>834</sup> Many of the most foundational rulings on EU law, including *Van Gend en Loos*<sup>835</sup> and *Costa v E.N.E.L.*,<sup>836</sup> were given in preliminary reference proceedings, further illustrating the importance of this mechanism.

However, national judges are not passive recipients, but authentic dialogue partners of the CJEU thanks to these procedures: this symbiosis ensures that the application of EU law is harmonised, consistent and fine-tuned to the unique legal landscape of each Member State. The cooperation between the CJEU and national courts is clearly one of the key requirements for this procedure to work effectively. Also, due to the diverse legal traditions and specific features of each Member State's legal framework, the uniform application of EU law does not occur effortlessly. The significance of the preliminary reference procedure is even more evident when considering the vast number of national judges responsible for upholding and implementing EU law in practical situations.

The ramifications of the preliminary reference procedure are palpable – not only in important areas such as the integrity of the Internal Market,<sup>837</sup> but also in the stability of the financial system.<sup>838</sup> The preliminary reference procedure is the key tool affording EU judges, when applying EU law, a uniform understanding of this law; if

---

\* Member of the Executive Board of the ECB and Vice-Chair of the Supervisory Board of the ECB.

<sup>834</sup> Opinion of 8 March 2011, *Draft agreement – Creation of a unified patent litigation system*, 1/09, ECLI:EU:C:2011:123.

<sup>835</sup> Judgement of 5 February 1963, *Van Gend en Loos v Administratie der Belastingen*, Case 26-62, ECLI:EU:C:1963:1.

<sup>836</sup> Judgement of 15 July 1964, *Costa v E.N.E.L.*, Case 6-64, ECLI:EU:C:1964:66.

<sup>837</sup> For instance, see the judgement of 4 October 2012, *Commission v Austria*, Case C-75/11, ECLI:EU:C:2012:605; the judgement of 12 March 1987, *Commission v Germany*, Case 178/84, ECLI:EU:C:1987:126; and the judgement of 30 November 1995, *Gebhard v Consiglio dell'Ordine degli Avvocati e Procuratori di Milano*, Case C-55/94, ECLI:EU:C:1995:411.

<sup>838</sup> For instance, see the judgement of 22 March 2018, *Anisimoviené and Others*, Joined Cases C-688/15, C-109/16, ECLI:EU:C:2018:209; the judgement of 13 September 2018, *Buccioni*, Case C-594/16, ECLI:EU:C:2018:717; and the judgement of 7 August 2018, *VTB Bank (Austria)*, Case C-52/17, ECLI:EU:C:2018:648.

such a procedure did not exist, the resulting legal cacophony would reverberate across national borders. Closer to our area of competence, key judgements such as *Pringle*<sup>839</sup> and *Gauweiler*<sup>840</sup> have had a huge impact on how we design and implement our monetary policy. In the field of banking supervision, we are tasked with applying EU law in the light of a number of important judgements such as *Peter Paul*,<sup>841</sup> *Baumeister*,<sup>842</sup> *Berlusconi-Fininvest*,<sup>843</sup> *Iccrea Banca*,<sup>844</sup> *FBF*<sup>845</sup> and *Kantarev*,<sup>846</sup> to mention but a few. Lastly, to conclude with an area which is particularly close to my heart, it is not implausible to expect that following the adoption of EU legislation to fight

---

<sup>839</sup> Judgement of 27 November 2012, *Pringle*, Case C-370/12, ECLI:EU:C:2012:756.

<sup>840</sup> Judgement of 16 June 2015, *Gauweiler and Others*, Case C-62/14, ECLI:EU:C:2015:400.

<sup>841</sup> Judgement of 12 October 2004, *Peter Paul*, Case C-222/02, ECLI:EU:C:2004:606.

<sup>842</sup> Judgement of 19 June 2018, *Baumeister*, Case C-15/16, ECLI:EU:C:2018:464.

<sup>843</sup> Judgement of 19 December 2018, *Berlusconi and Fininvest*, Case C-219/17, ECLI:EU:C:2018:1023.

<sup>844</sup> Judgement of 3 December 2019, *Iccrea Banca*, Case C-411/18, ECLI:EU:C:2019:1036.

<sup>845</sup> Judgement of 15 July 2021, *FBF*, Case C-911/19, ECLI:EU:C:2021:599.

<sup>846</sup> Judgement of 4 October 2018, *Kantarev*, Case C-571/16, ECLI:EU:C:2018:807.



climate change,<sup>847</sup> new cases in this field will reach the CJEU through the preliminary reference procedures.<sup>848</sup>

The importance of the preliminary reference mechanism can also be inferred by looking at the increasing trend in terms of the number of requests that have been brought before the European Court of Justice (ECJ) over time. This upward trend has recently led the CJEU to submit a request for the amendment of its Statute.<sup>849</sup> The amendment is aimed – inter alia – at transferring jurisdiction for hearing and determining requests for a preliminary ruling in specific areas to the General Court. If

---

<sup>847</sup> Regulation (EU) 2021/1119 of the European Parliament and of the Council of 30 June 2021 establishing the framework for achieving climate neutrality and amending Regulations (EC) No 401/2009 and (EU) 2018/1999 ('European Climate Law') (OJ L 243, 9.7.2021, p. 1). See also the "Fit for 55" legislation: Directive (EU) 2023/959 of the European Parliament and of the Council of 10 May 2023 amending Directive 2003/87/EC establishing a system for greenhouse gas emission allowance trading within the Union and Decision (EU) 2015/1814 concerning the establishment and operation of a market stability reserve for the Union greenhouse gas emission trading system (OJ L 130, 16.5.2023, p. 134); Regulation (EU) 2023/955 of the European Parliament and of the Council of 10 May 2023 establishing a Social Climate Fund and amending Regulation (EU) 2021/1060 (OJ L 130, 16.5.2023, p. 1); Directive (EU) 2023/958 of the European Parliament and of the Council of 10 May 2023 amending Directive 2003/87/EC as regards aviation's contribution to the Union's economy-wide emission reduction target and the appropriate implementation of a global market-based measure (OJ L 130, 16.5.2023, p. 115); Decision (EU) 2023/136 of the European Parliament and of the Council of 18 January 2023 amending Directive 2003/87/EC as regards the notification of offsetting in respect of a global market-based measure for aircraft operators based in the Union (OJ L 19, 20.1.2023, p. 1); Regulation (EU) 2023/957 of the European Parliament and of the Council of 10 May 2023 amending Regulation (EU) 2015/757 in order to provide for the inclusion of maritime transport activities in the EU Emissions Trading System and for the monitoring, reporting and verification of emissions of additional greenhouse gases and emissions from additional ship types (OJ L 130, 16.5.2023, p. 105); Regulation (EU) 2023/857 of the European Parliament and of the Council of 19 April 2023 amending Regulation (EU) 2018/842 on binding annual greenhouse gas emission reductions by Member States from 2021 to 2030 contributing to climate action to meet commitments under the Paris Agreement, and Regulation (EU) 2018/1999 (OJ L 111, 26.4.2023, p. 1); Regulation (EU) 2023/839 of the European Parliament and of the Council of 19 April 2023 amending Regulation (EU) 2018/841 as regards the scope, simplifying the reporting and compliance rules, and setting out the targets of the Member States for 2030, and Regulation (EU) 2018/1999 as regards improvement in monitoring, reporting, tracking of progress and review (OJ L 107, 21.4.2023, p. 1); Proposal for a Directive of the European Parliament and of the Council amending Directive (EU) 2018/2001 of the European Parliament and of the Council, Regulation (EU) 2018/1999 of the European Parliament and of the Council and Directive 98/70/EC of the European Parliament and of the Council as regards the promotion of energy from renewable sources, and repealing Council Directive (EU) 2015/652 (COM/2021/557 final); Directive (EU) 2023/1791 of the European Parliament and of the Council of 13 September 2023 on energy efficiency and amending Regulation (EU) 2023/955 (recast) (OJ L 231, 20.9.2023, p. 1); Regulation (EU) 2023/851 of the European Parliament and of the Council of 19 April 2023 amending Regulation (EU) 2019/631 as regards strengthening the CO<sub>2</sub> emission performance standards for new passenger cars and new light commercial vehicles in line with the Union's increased climate ambition (OJ L 110, 25.4.2023, p. 5); Regulation (EU) 2023/1804 of the European Parliament and of the Council of 13 September 2023 on the deployment of alternative fuels infrastructure, and repealing Directive 2014/94/EU (OJ L 234, 22.9.2023, p. 1); Proposal for a Regulation of the European Parliament and of the Council on ensuring a level playing field for sustainable air transport (COM/2021/561 final); Regulation (EU) 2023/1805 of the European Parliament and of the Council of 13 September 2023 on the use of renewable and low-carbon fuels in maritime transport, and amending Directive 2009/16/EC (OJ L 234, 22.9.2023, p. 48); and Regulation (EU) 2023/956 of the European Parliament and of the Council of 10 May 2023 establishing a carbon border adjustment mechanism (OJ L 130, 16.5.2023, p. 52).

<sup>848</sup> As long as the Court does not review its *Plaumann* test, an action for annulment does not seem to be a viable option (see the judgement of 25 March 2021, *Carvalho*, Case C-565/19 P, ECLI:EU:C:2021:252 as well as the Order of 14 January 2021, *Sabo*, Case C-297/20P, ECLI:EU:C:2021:24). Also, many cases relating to the EU Emissions Trading Scheme have been submitted to the CJEU via preliminary references. The preliminary reference procedure seems therefore to be the most promising avenue through which to seek judicial enforcement of the obligations deriving from the Paris Agreement. See also Pagano, M. (2019) "Climate change litigation before EU Courts and the 'butterfly effect'", 16 October, in *blogdroiteuropeen*, available at: <https://blogdroiteuropeen.com/2019/10/16/climate-change-litigation-before-eu-courts-and-the-butterfly-effect-by-mario-pagano/>, last accessed on 6 November 2023, as well as Setzer, J. et al., (2022) "Climate litigation in Europe", p. 23 ff., available at [https://www.lse.ac.uk/granthaminstitute/wp-content/uploads/2022/12/Climate-litigation-in-Europe\\_A-summary-report-for-the-EU-Forum-of-Judges-for-the-Environment.pdf](https://www.lse.ac.uk/granthaminstitute/wp-content/uploads/2022/12/Climate-litigation-in-Europe_A-summary-report-for-the-EU-Forum-of-Judges-for-the-Environment.pdf), last accessed on 6 November 2023.

<sup>849</sup> Protocol (No 3) on the Statute of the Court of Justice of the European Union (OJ C 202, 7.6.2016, p. 210).

implemented, this reform could alleviate the heavy workload of the CJEU and create space for the latter to focus on matters of higher constitutional relevance,<sup>850</sup> including enhancing judicial dialogue with national courts. This proposal triggered our interest in discussing, at this ECB Legal Conference, whether and how the role of preliminary references may develop if the proposal is approved.

In this concise submission, I would like to highlight pivotal points that emerged from the panel's discussions. I will focus on the historical development of the preliminary reference procedure (Part 2), the importance of judicial dialogue for this procedure to work (Part 3), and some first reflections on the proposed reform of the CJEU Statute (Part 4) before concluding (Part 5).

## 2 The quest for uniformity and pluralism in EU law from a historical perspective

The preliminary ruling procedure has played an important role in constitutionalising EU law, as we were reminded by **Professor Garben**.<sup>851</sup> She highlighted how, from a historical perspective, the preliminary reference procedure developed in connection with the doctrine of direct effect. More than this, the very existence of the preliminary reference procedure has been used by the CJEU for several purposes: (i) as an important argument in support of the principle of supremacy of EU law; (ii) to argue that the autonomy of EU law flows directly from the Treaty, rather than through the national constitutions; and (iii) to acknowledge the existence of a new legal order, the subjects of which are not only Member States but also individual citizens.

This gradual emancipation of EU law from international law is at the core of the process of constitutionalisation of EU law, whereby EU legal norms are applied and enforced by judges across the EU. Such a process has created a pan-European judicial order comprising the EU courts as well as the national courts, at the apex of which stands the CJEU. In turn, this new judicial order has forged a new relationship between the EU legal system and its subjects, which is mediated primarily by courts and has transformed litigants into enforcers of EU law thanks to their use of preliminary references. The preliminary reference procedure has thus been essential for the foundation and effectiveness of the EU legal system: it has allowed the national courts to contribute to the development of the system, and provided a channel through which to develop new doctrines.

According to Professor Garben, over time there has been a shift from the initial connection between the doctrine of direct effect and the preliminary reference procedure towards a more prominent connection between the latter and the principle of supremacy of EU law. Professor Garben maintains that this shift has been the trigger for increasing contestation of the principle of supremacy by national courts. To support this assertion, she referred to five cases raised by as many higher national

---

<sup>850</sup> Hinarejos, A. (2009), "The ECJ as a Federal Constitutional Court" in Hinarejos, A. *Judicial Control in the European Union: Reforming Jurisdiction in the Intergovernmental Pillars*, Oxford University Press, pp. 1-13.

<sup>851</sup> Garben, S., *The past, present and future of the preliminary reference procedure*, in this volume.

courts in the last decade.<sup>852</sup> In her view, at the core of this contestation is a challenge to the authority of lower national courts to set aside national law that is not compliant with EU law – an authority that is grounded in the direct dialogue with the CJEU through the preliminary reference procedure.

Against this background, Professor Garben raised some doubts about the connection more recently developed by the CJEU between the preliminary reference procedure and the independence of the judiciary, in the light of the rule of law principle to be enforced on Member States. She then argued, in conclusion, that uniformity may need to be sacrificed to some degree in the name of pluralism, but the proposed reform of the Statute of the CJEU is not a step in this direction. These critical remarks sparked an intense and animated debate with the other speakers and the audience.

### 3 The importance of judicial dialogue

The fact that only five cases can be mentioned as a proof of contestation of the principle of supremacy was stressed by **Di Bucci**, to rebut the very existence of such contestation. He recalled that, over the years, in the vast majority of cases national courts have chosen to follow the interpretation of EU law proposed by the CJEU. He then analysed the five cases in detail, arguing that they are not only exceptional, but also rather heterogeneous. With the exception of the Romanian<sup>853</sup> and Polish<sup>854</sup> cases, against which infringement procedures are ongoing, he asserted that they cannot be considered acts of open contestation. In one case the real dispute was between a Czech and a Slovak Court.<sup>855</sup> The Danish case,<sup>856</sup> although more serious in nature, was limited in scope. And even in the German case<sup>857</sup> ultimately the divergence was on the standard of review rather than on the interpretation of EU law. Most importantly, in reaction to an infringement procedure initiated by the European Commission,<sup>858</sup> the German Government restated the autonomy of the EU legal order, the supremacy of EU law and the importance of its effectiveness and uniform application, as well as the authority of the CJEU, whose decisions are final and binding.<sup>859</sup> Di Bucci thus concluded this analysis by arguing that, if anything, these cases have shed light on a constitutional crisis within some Member States rather than at the level of the EU legal order.

---

<sup>852</sup> Judgement of 22 June 2011, *Landtová*, Case C-399/09, ECLI:EU:C:2011:111; judgement of 19 April 2016, Case C-441/14, *Dansk Industri*, ECLI:EU:C:2016:278; judgement of 11 December 2018, *Weiss*, Case C-493/17, ECLI:EU:C:2018:1000; judgement of the Polish Constitutional Tribunal of 7 October 2021, K 3/21; judgement of 18 May 2021, *Asociația "Forumul Judecătorilor din România"*, joined cases C-83/19, C-127/19, C-195/19, C-291/19, C-355/19 and C-397/19, ECLI:EU:C:2021:393.

<sup>853</sup> Judgement of 7 September 2023, *Asociația "Forumul Judecătorilor din România"*, Case C-216/21, ECLI:EU:C:2023:628.

<sup>854</sup> Action brought on 17 July 2023, *European Commission v Republic of Poland*, Case C-448/23 (pending).

<sup>855</sup> Judgement of 22 June 2011, *Landtová*, Case C-399/09, ECLI:EU:C:2011:111.

<sup>856</sup> Judgement of 19 April 2016, Case C-441/14, *Dansk Industri*, ECLI:EU:C:2016:278.

<sup>857</sup> Judgement of 11 December 2018, *Weiss*, Case C-493/17, ECLI:EU:C:2018:1000.

<sup>858</sup> European Commission, *Primacy of EU law: Commission sends letter of formal notice to GERMANY for breach of fundamental principles of EU law*.

<sup>859</sup> European Commission, *Primacy of EU law: Commission closes infringement procedure based on formal commitments of GERMANY clearly recognising the primacy of EU law and the authority of the Court of Justice of the European Union*.

Di Bucci then turned back to the history of preliminary references to stress that, since the outset, the preliminary reference procedure has been embraced by lower national courts as a form of self-empowerment.<sup>860</sup> The procedure has proven to be very flexible and versatile. Higher national courts, however, have also shown themselves able to engage in fruitful cooperation to find commonly agreed solutions, as in the *Taricco* saga,<sup>861</sup> or in the *La Quadrature du Net* judgement.<sup>862</sup> These cases show that judicial contestation is not such a success story, and mutual cooperation grounded on judicial dialogue has prevailed. This in turn has allowed the preliminary reference procedure to be wielded as a very versatile and flexible tool.

Over time, preliminary references have been used in a number of ways: (i) to indirectly assess the compatibility of national law with EU law; (ii) to identify fundamental principles of EU law (such as the principles of direct effect and of the primacy of EU law); (iii) to clarify the respective competences of the EU and Member States; (iv) to lay down requirements on national legal orders and judiciaries when EU law is at stake; and (v) to enforce respect for fundamental rights by EU institutions and also by Member States when they apply EU law. All these developments were enabled by an institutional innovation deliberately introduced by those who drafted the Treaty of Rome. They expanded the scope of the preliminary reference procedure, previously limited to the review of validity of EU law under the European Coal and Steel Community (ECSC) Treaty,<sup>863</sup> to also include the interpretation of EU law<sup>864</sup> with the aim of ensuring the uniformity of EU law.

Clearly, in cases of disagreement between courts, the standard according to which the divergence is solved is the most important factor. Solutions to disagreements would be impossible if we had as many concurrent standards as national legal orders. In view of this, Di Bucci concluded that there is no apparent need for institutional innovations or new procedures to address constitutional clashes between EU and national courts, as continued commitment to judicial dialogue remains the main avenue to avert such risk.

## 4 Future perspectives?

**Di Bucci**<sup>865</sup> noted that the proposed reform of the CJEU Statute<sup>866</sup> should be seen against the background of the ECJ having reached the limit of its capacity in terms of workload. The proposal may thus be seen as instrumental to addressing the potential

---

<sup>860</sup> Weiler, J.H.H. (1991), "The transformation of Europe", *The Yale Law Journal*, Vol. 100, No 8, pp. 2403-2483.

<sup>861</sup> Judgement of 8 September 2015, *Taricco and Others*, Case C-105/14, ECLI:EU:C:2015:555.

<sup>862</sup> Judgement of 6 October 2020, *La Quadrature du Net and Others*, Joined Cases C-511/18, C-512/18 and C-520/18, ECLI:EU:C:2020:791.

<sup>863</sup> Article 41 of the Treaty establishing the European Coal and Steel Community.

<sup>864</sup> Article 177 of the Treaty establishing the European Economic Community.

<sup>865</sup> Di Bucci, V., *Preliminary rulings: their development and their acceptance*, in this volume.

<sup>866</sup> The Court of Justice recently proposed a draft amendment of Protocol No 3 on the Statute of the ECJ, in accordance with Article 281(2) of the Treaty on the Functioning of the European Union.

divergences between the CJEU and national courts, in that it would create more space<sup>867</sup> for the former to engage in judicial dialogue with national courts.

**Judge Rossi** remarked on the importance of judicial dialogue among courts from a historical as well as a forward-looking perspective. She observed that in fact criticism of the principle of supremacy is as old as the principle itself, and its manifestations in judicial decisions by national courts are to be seen as steps that those national courts undertake as part of the process of “learning the language of judicial dialogue”. By way of example, she mentioned the first “case of rebellion” in 1973,<sup>868</sup> whereby the Italian Constitutional Court, not unlike the Romanian Constitutional Court today, asserted the jurisdiction of national courts to adjudge on the compliance of national law with EU law. Since then, several steps have been taken in a process of approximation, including the historical judgement in *Simmenthal*, whereby the ECJ clarified that all national courts are courts of the EU.<sup>869</sup> Fast forward to half a century after *Frontini* and the Italian Constitutional Court is now considered a champion of effective judicial dialogue between the CJEU and national courts:<sup>870</sup> sooner or later all national courts which have interacted with the EU legal order have felt threatened by the principle of supremacy, but judicial dialogue has always prevailed in the end. And this will continue to be the case.

The theoretical foundation of the principle of supremacy is indeed the equality of Member States, and equality among EU citizens, as enshrined in Article 4 of the Treaty on European Union (TEU). There would be no scope for such equality if EU law was no longer interpreted in a uniform manner across the EU, and – needless to say – the preliminary reference procedure is instrumental to achieving this aim.

When challenging the principle of supremacy, national courts are effectively interpreting a corollary of the principle of equality under the Treaty, namely interfering with a matter falling within the exclusive jurisdiction of the CJEU. Although declarations annexed to the Treaties are not part of the Treaties themselves, under international law they are recognised as means of interpretation of the Treaties to which they are attached. Against this background, Declaration No 17 annexed to the Treaties<sup>871</sup> emphasises: (i) the existence of the primacy principle; (ii) in the terms affirmed by the CJEU in *Costa v E.N.E.L.* in 1964; and (iii) that the fact that the principle is not mentioned in the Treaty itself is not relevant. In her written contribution to this book,

---

<sup>867</sup> Although the ECJ would retain control of the most controversial areas, taken together the preliminary references transferred to the General Court would amount to 20% of the cases currently referred to the CJEU. The areas of jurisdiction which would be transferred include: (i) the common system of value added tax; (ii) excise duties; (iii) the Union Customs Code and the tariff classification of goods under the Combined Nomenclature; (iv) compensation of and assistance to passengers; and (v) the scheme for greenhouse gas emission allowance trading.

<sup>868</sup> Judgement of the Italian Constitutional Court of 27 December 1973, *Frontini v Minister delle Finanze*, No 183.

<sup>869</sup> Judgement of 9 March 1978, *Simmenthal*, Case 106/77, ECLI:EU:C:1978:49.

<sup>870</sup> Judgement of 5 December 2017, *M.A.S. and M.B. (Taricco II)*, Case C-42/17, ECLI:EU:C:2017:936.

<sup>871</sup> Declarations annexed to the Final Act of the Intergovernmental Conference which adopted the Treaty of Lisbon, signed on 13 December 2007. A. Declarations concerning provisions of the Treaties No 17 Declaration concerning primacy (OJ C 115, 9.5.2008, p. 344).

Judge Rossi has elaborated further on the limited impact the proposed reform has in the field of the banking union.<sup>872</sup>

## 5 Conclusion

A historical overview of the preliminary reference procedure and its development sheds light on the importance of this tool. It has played a crucial role in the development of the EU legal system and its principles, and ensures their effectiveness and uniform application across the EU. Such developments can be traced back to the intentions of those who drafted the Treaty, as they allowed references to the interpretation of EU law with the precise aim of pursuing the uniform application of EU law across all Member States. The connection between the preliminary reference procedure and the principle of supremacy exposes the former to the criticism which is raised against the latter. Yet for more than half a century national courts have shown an enthusiastic adhesion to the use of this tool to engage in judicial dialogue with the CJEU, and to following the latter's guidance on the interpretation of EU law in line with the principle of supremacy.

The few cases in which national courts have challenged the principle of supremacy may thus be seen as exceptions, rather than evidence of an increasing contestation of the principle. Against this background, the proposed reform of the CJEU Statute could be seen as a way to effectively, albeit indirectly, address these exceptional divergences. The transfer of certain categories of preliminary references to the General Court would allow more time and energy for the ECJ to focus on judicial dialogue when this is warranted by the complexity of the case at hand.

Thus the transfer to the General Court of adjudication on some preliminary references does not seem to be a prelude to the demise of this tool. If anything, its importance seems to be on the rise in the context of the further development of EU law. New areas are emerging where the intervention of the CJEU may be sought to ensure the uniform application of EU law, such as in the field of climate and nature-related litigation. Meanwhile judicial dialogue between the national courts and the CJEU is needed more than ever, so that the preliminary reference procedure can continue to be considered the crown jewel of the CJEU.

---

<sup>872</sup> Rossi, L.S., *Effective judicial review in the banking union*, in this volume.

# The past, present and future of the preliminary reference procedure

Sacha Garben\*

## 1 Introduction<sup>σ</sup>

This contribution reflects on the past, the present and the future of one of the most important and characteristic legal features of the European Union (EU): the preliminary reference procedure (PRP). This innovative procedural device – currently laid down in Article 267 Treaty on the Functioning of the European Union (TFEU) – has played a crucial role in what is often referred to as ‘the constitutionalisation of EU law’, by which is meant the evolution of the EU legal order from an international Treaty to a legal system that through the doctrines of primacy and direct effect claims (a degree of) final authority. In particular, the PRP has allowed the Court of Justice of the European Union (CJEU) “to realise a pan-Union judicial order”, comprising both EU and domestic courts, “with its own rules of jurisdiction, allocation of responsibilities and judicial hierarchies, and collective goals”.<sup>873</sup>

As standard accounts of European integration highlight, the empowerment through the PRP of national judiciaries vis-à-vis national political actors solicited the cooperation of (especially lower) national courts in the building of this new legal order in the early years of European construction<sup>874</sup> and turned the PRP in the main vehicle of both the direct effect and the primacy of EU law, in the name of EU law’s uniformity and effectiveness, over time.

Yet, this narrative of success masks a more complicated reality. The EU legal order that has emerged from this is one in which national courts are not merely empowered to enforce individuals’ rights under the Treaties and invited to play a serious role in the construction of Europe, but one in which they operate in a strictly defined framework of obligations concerning their duties to refer and to apply EU law at the detriment of conflicting national law, which in extremis may require them to disregard or subvert the fundamental constitutional principles, rules and procedures that provide the very

---

\* Professor of EU law at the Legal Studies Department of the College of Europe, Bruges. All views expressed in this chapter are strictly personal.

<sup>σ</sup> Article 267 TFEU: The Court of Justice of the European Union shall have jurisdiction to give preliminary rulings concerning: (a) the interpretation of the Treaties; (b) the validity and interpretation of acts of the institutions, bodies, offices or agencies of the Union; Where such a question is raised before any court or tribunal of a Member State, that court or tribunal may, if it considers that a decision on the question is necessary to enable it to give judgment, request the Court to give a ruling thereon. Where any such question is raised in a case pending before a court or tribunal of a Member State against whose decisions there is no judicial remedy under national law, that court or tribunal shall bring the matter before the Court. If such a question is raised in a case pending before a court or tribunal of a Member State with regard to a person in custody, the Court of Justice of the European Union shall act with the minimum of delay.

<sup>873</sup> D. Chalmers, G. Davies, G. Monti, V. Heyvaert, *European Union Law: Text and Materials*, CUP (2023 forthcoming).

<sup>874</sup> J. Weiler, ‘Transformation of Europe’, *Yale Law Journal* (1991), p. 2426.

framework for their existence, responsibility, and legitimacy. Especially higher courts have proven at times reluctant – at times resistant – to this hierarchical structure that positions EU law, as interpreted by the CJEU, at the apex of its self-defined authority.

After many years in which these conflicts remained somewhat theoretical or indirect, the past decade has seen several highest<sup>875</sup> courts from different Member States outright refusing to apply a preliminary ruling of the CJEU. Complicating the picture is that this new, confrontational, phase of constitutional contestation partially overlaps with the rule of law conflict between the EU and several Member States, in which the CJEU and respective national courts have become enmeshed.

Although it is understandable that the EU institutions see this as a reason to insist more strongly than before on enforcing the full primacy doctrine as formulated by the CJEU, there are – precisely from a perspective of constitutional democracy – important reasons to heed the constitutional reservations that are shared by the highest national courts of all Member States about the final source of authority in the composite European polity. This state of constitutional pluralism should, in the absence of a true European Constitution actively endorsed by the People(s) of Europe, be accepted, and the PRP should be the main vehicle to operationalise it. For that purpose, it should be reinterpreted as a platform for true judicial and constitutional dialogue in a spirit of cooperation and pluralism.

## 2 The PRP and the EU's 'constitutional claim'

The PRP is often said to be the 'crown jewel' in the CJEU's jurisdiction.<sup>876</sup> The image conveyed is an appropriate one, as the procedure has been so very instrumental in the development of the authority of EU law, in its claim to (a degree of)<sup>877</sup> sovereign power vested in the Treaties as interpreted by the CJEU.

### 2.1 The EEC Treaty

The Treaty of Rome establishing the European Economic Community (EEC), born of a post-war period where elites were self-consciously engaged in constitutional entrepreneurship with the objective to curb the excesses of nationalistic power through

---

<sup>875</sup> See on a peculiar resistance of lower courts in the context of the *Sturgeon* case-law of the CJEU: S. Garben, 'ky-high controversy and high-flying claims? The *Sturgeon* case law in light of judicial activism, Euroscepticism and eurolegalism' *Common Market Law Review*, 50(1) (2013), p. 15.

<sup>876</sup> M. Shapiro, 'The European Court of Justice' in P. Craig and G. De Búrca (eds.), *The Evolution of EU Law*, OUP (1999).

<sup>877</sup> It takes until Opinion 1/91 for the Court to replace the 'limited fields' of *Van Gend en Loos* by 'ever-wider fields'. Opinion 1/91 of 14 December 1991, *Accord EEE – I*, ECLI:EU:C:1991:490. The 'erosion of the principle of conferral' through the expansive approach to EU competence (and self-executing Treaty norms), leads to a situation where there 'simply is no nucleus of sovereignty that the Member States can invoke, as such, against the Community' (K. Lenaerts, 'Constitutionalism and the many faces of Federalism' *The American Journal of Comparative Law*, 38 (1990), p. 205). See J. Weiler, 'Transformation of Europe', *Yale Law Journal* (1991). This is an important part of the story of the constitutionalisation of EU law, but lies outside the scope of this chapter. NB: in the recent *RS* judgment the Court replaced 'ever wider fields' by 'in the fields defined by the Treaties' which may signal a change in approach to the conferral principle in the wake of the constitutional contestation discussed in this chapter. Judgment of 22 February 2022, Case C-430/21, *RS*, ECLI:EU:C:2022:99.



a re-organization/dispersion of (the exercise of) authority at the national and the international level, contained various politically ambitious elements. The preamble proclaimed that the Treaty laid the foundations of an “ever-closer Union” among “the peoples of Europe”, it created supranational institutions including a Parliamentary Assembly and a decision-making process that could break with the traditional veto of intergovernmentalism. But arguably (even) more important were two legally innovative elements: the mention of an instrument (the regulation) that would be “directly applicable” without national transposition, which literally interpreted would bypass the traditional monist/dualist question in international law, and moreover a procedure that allowed national courts to refer questions of interpretation and validity of EU law to the CJEU: the PRP.

If the text of the EEC Treaty itself, ambitious as it was, was still a very long way from creating anything that could warrant the label of truly ‘constitutional’,<sup>878</sup> that changed, as is well-known, with a string of landmark rulings amounting, taken together, to a constitutive constitutional claim, namely to an autonomous legal order that possesses authority that is final and direct, and that is inherently materially open-ended.<sup>879</sup> The PRP has played a crucial role in this development: directly and indirectly, theoretically and practically, legally and politically.

## 2.2 The PRP and Van Gend en Loos<sup>σ</sup>

In the seminal *Van Gend en Loos* judgment, where the Court developed the direct effect of EU law, as well as its autonomous nature, the Court uses the existence of the PRP as one of the main arguments to justify this doctrine. The Court reasons that having such a procedure confirms that EU law is supposed to have a direct meaning in national judicial proceedings. As such, it is one of the crucial elements that support the creation of both the landmark doctrine of direct effect – under which individuals can in national judicial proceedings directly rely on provisions of EU law that grant them rights which national court must protect – and the Court’s core constitutional statement that the EU is a “new legal order of international law for the benefit of which

---

<sup>878</sup> Many national constitutions included clauses permitting the participation in the European project, showing an awareness of the constitutional relevance of the integration project from the beginning. Yet none of these clauses supports a conception of the EU legal order and its authority as autonomously derived, independent from the national constitutions and the fundamental rights and principles therein. Instead, national constitutions set limitations – either implicitly or explicitly – to the authority of the EU, which is precisely against the CJEU’s claim. See for an overview Stefan Griller et al., ‘National Constitutional Law and European Integration’ (2011) Study for the European Parliament’s Committee on Constitutional Affairs, available at: [https://www.europarl.europa.eu/RegData/etudes/etudes/join/2011/432750/IPOL-AFCO\\_ET\(2011\)432750\\_EN.pdf](https://www.europarl.europa.eu/RegData/etudes/etudes/join/2011/432750/IPOL-AFCO_ET(2011)432750_EN.pdf).

<sup>879</sup> See in further detail S. Garben, ‘The constitutionalization of European integration as a single, protracted ‘constitutional moment’ towards the establishment of EU final authority’ in M. Dani, M. Goldoni and A.J. Menéndez, *The Legitimacy of European Constitutional Orders*, Edward Elgar (2024), pp. 259–281.

<sup>σ</sup> *Van Gend en Loos*: In addition, the task assigned to the Court of Justice under Article 177 [the PRP], the object of which is to secure uniform interpretation of the Treaty by national courts and tribunals, confirms that the states have acknowledged that Community law has an authority which can be invoked by nationals before those courts and tribunals. The conclusion to be drawn from this is that the Community constitutes a new legal order of international law for the benefit of which the states have limited their sovereign rights, albeit within limited fields, and the subjects of which comprise not only Member States but also their nationals. Independently of the legislation of Member States, Community law therefore not only imposes obligations on individuals but is also intended to confer upon them rights which become part of their legal heritage.

the States have limited their sovereign rights, albeit within limited fields, and the subjects of which comprise not only Member States but also their nationals”.

The PRP was not the only justification for the creation of the direct effect and autonomous legal order doctrines, but it is hard to see how these doctrines could have ever operated effectively without it. The question of the EU’s authority could – and probably would - have been raised by the European Commission through the centralised enforcement procedure, but any answer of the Court proclaiming direct effect of EU law on its own terms (i.e. disregarding national constitutional arrangements concerning the effect of international law in the domestic order) would in that scenario have had to be applied and enforced ‘traditionally’ via the national political and judicial institutions and procedures. Precisely this would have been unlikely to achieve the ‘autonomy’ of the authority of EU law – as also the next monumental preliminary reference, in *Costa v ENEL*, illustrates.

### 2.3 The PRP and *Costa v ENEL*<sup>σ</sup>

In *Costa v ENEL*, the preliminary question by the Italian Court inquired as to the compatibility of a law nationalizing the electricity industry in Italy with a number of provisions of the EEC Treaty. Probably precisely in awareness of the transformative potential of the PRP as unlocked by *Van Gend en Loos*, the Italian government argued that the preliminary reference in question was “absolutely inadmissible” because (i) the issue did not in reality concern the objective of the PRP, namely to procure an interpretation of EU law in order for the national court to be able to adjudicate the proceedings before it, but instead concerned an attempt to challenge the validity of a national law – something that should instead take place through the centralised enforcement procedure, and (ii) because there was a clear national law that applied, and in such as case a national court was obliged to apply the national law and could not avail itself of the PRP.

To the first argument, the CJEU replied that while indeed it does not have the jurisdiction under the PRP to apply the Treaty to a specific case or to decide upon the validity of a national provision in relation to the Treaty, it may reinterpret the question of the validity of national law as a question of interpretation of the respective Treaty provisions “in the context of the points of law” raised by the national court. As such, it confirmed the significant enforcement capacity of the PRP, which would help the EU legal order overcome some of the most fundamental limitations of international law.

As to the second argument, the Court held that by contrast with ordinary international Treaties, the EEC Treaty had created its own legal system which became an integral

---

<sup>σ</sup> *Costa ENEL*: It follows from all these observations that the law stemming from the Treaty, an independent source of law, could not, because of its special and original nature, be overridden by domestic legal provisions, however framed, without being deprived of its character as Community law and without the legal basis of the Community itself being called into question. The transfer by the states from their domestic legal system to the Community legal system of the rights and obligations arising under the Treaty carries with it a permanent limitation of their sovereign rights, against which a subsequent unilateral act incompatible with the concept of the Community cannot prevail. Consequently Article 177 [the PRP] is to be applied regardless of any domestic law, whenever questions relating to the interpretation of the Treaty arise.

part of the legal systems of the Member States and which their courts are bound to apply. Reinforcing the findings in *Van Gend en Loos* about the ‘new legal order’, the Court referred to “a Community of unlimited duration, having [...] real powers stemming from [...] a transfer of powers from the states to the Community”, which “carries with it a permanent limitation of their sovereign rights” and to “the law stemming from the Treaty, an independent source of law [of] special and original nature”, in order to conclude that in the face of such authority “a subsequent unilateral act incompatible with the concept of the Community cannot prevail” and that thus the preliminary reference had to be admissible.

What follows is that the precedence of EU law over conflicting national law is, in reasoning and in reality, intrinsically connected to the responsibilities of national courts under the PRP. Differently from international law, where the normative hierarchy in which international law outranks national law lacks direct legal teeth, primacy in EU law translates into actual precedence being given in concrete cases by national courts, an act in support of which they may rely on the PRP.

## 2.4 The PRP, the national constitution, and national (constitutional) courts: *Internationale Handelsgesellschaft* and *Simmenthal*<sup>σ</sup>

Although already in *Costa v ENEL* the Court held that EU law would take precedence over domestic legal provisions “however framed”, the sensitive issue of the relationship between EU law and national constitutions would be more explicitly addressed in the preliminary reference in *Internationale Handelsgesellschaft*.<sup>880</sup> The Court ruled that the primacy of EU law also applies to national constitutions, including the fundamental human rights laid down therein. In order to justify the disapplication of these most fundamental legal norms at national level, the Court proclaims that it will protect these as general principles of law at EU level. Nevertheless, the ‘absolute’<sup>881</sup> primacy of EU law that follows from this, where (ad absurdum) a technical provision in an EU regulation takes precedence over the most sacred norms of national constitutional law,<sup>882</sup> has proven controversial – as we shall discuss below.

---

<sup>σ</sup> *Internationale Handelsgesellschaft*: ...the validity of a Community measure or its effect within a Member State cannot be affected by allegations that it runs counter to either fundamental rights as formulated by the constitution of that State or the principles of a national constitutional structure.

<sup>880</sup> Judgment of 17 December 1970, Case 11-70, *Internationale Handelsgesellschaft*, ECLI:EU:C:1970:114.

<sup>881</sup> R. Schütze, ‘(Legal) Primacy’ in R. Schütze, *An Introduction to European Law*, OUP (2023).

<sup>882</sup> S. Weatherill, *Law and Integration in the European Union*, OUP (1995), p. 106.

The displacement of the national constitution as the locus of final authority in the national legal order that follows from the primacy doctrine as manifested in *Internationale Handelsgesellschaft* also entails a concordant displacement of national constitutional courts in relation to EU law. Furthermore, by stressing in *Simmenthal* that national rules that would reserve the power to disapply national legislation to a specific national court were not allowed and that all courts should have the power to disapply national legislation for conflict with EU law norms having direct effect, the duties of national courts under the PRP as interpreted by the CJEU displace the final authority of national constitutional/supreme courts 'internally' vis-à-vis lower courts, as these are directly empowered by EU law to bypass and 'overrule' higher courts when it comes to issues of EU law.<sup>883</sup>

### 3 The PRP and the reception of the EU's 'constitutional claim' by national courts

#### 3.1 The PRP as empowerment of (which) national courts?<sup>σ</sup>

As was discussed in the previous section, the PRP has been crucial for the theoretical foundation of the EU's 'pure', direct authority, and in more practical terms in the emancipation of the effect of this authority beyond the confines of traditional international law (reliant on "the notion and doctrinal apparatus of state responsibility, reciprocity and countermeasures"<sup>884</sup>) towards something akin to national, Federal authority: legal norms applied and enforced by the network of national courts, who have been turned into EU courts. The PRP has made individual litigants 'enforcers' of

---

<sup>883</sup> A national court which is called upon, within the limits of its jurisdiction, to apply provisions of Community law is under a duty to give full effect to those provisions, if necessary by refusing of its own motion to apply any conflicting provision of national legislation, and it is not necessary for the court to request or await the prior setting aside of such provision by legislative or other constitutional means'. Judgment of 7 February 1991, Case C-184/89, *Helga Nimz v Freie und Hansestadt Hamburg*, ECLI:EU:C:1991:50, building on Judgment of 9 March 1978, Case 106/77, *Simmenthal*, ECLI:EU:C:1978:49. See also Judgment of 19 November 2009, Case C-314/08, *Filipiak*, ECLI:EU:C:2009:719; Judgment of 8 September 2010, Case C-409/06, *Winner Wetten*, ECLI:EU:C:2010:503; Judgment of 22 June 2010, Joined cases C-188/10 and C-189/10, *Melki and Abdeli*, ECLI:EU:C:2010:363. Recently in Judgment of 22 February 2022, Case C-430/21, *RS*, ECLI:EU:C:2022:99, para. 75: "The national court, having exercised the discretion conferred on it by the second paragraph of Article 267 TFEU, must [...], if necessary, disregard the rulings of a higher national court if it considers, having regard to the interpretation provided by the Court, that they are not consistent with EU law, if necessary refusing to apply the national rule requiring it to comply with the decisions of that higher court".

<sup>σ</sup> Last but not least, noble ideas (such as the Rule of Law and European Integration) aside, the legally driven constitutional revolution was a narrative of plain and simple judicial empowerment. The empowerment was not only, or even primarily, of the European Court of Justice, but of the Member State courts, of lower national courts in particular. Whereas the higher courts acted diffidently at first, the lower courts made wide and enthusiastic use of the Article 177 procedure. This is immediately understandable both on a simple individual psychological level and on a deep institutional plane. Lower courts and their judges were given the facility to engage with the highest jurisdiction in the Community and thus to have de facto judicial review of legislation. For many this would be heady stuff. Even in legal systems such as that of Italy, which already included judicial review, the E.C. system gave judges at the lowest level powers that had been reserved to the highest court in the land. Institutionally, for courts at all levels in all Member States, the constitutionalization of the Treaty of Rome, with principles of supremacy and direct effect binding on governments and parliaments, meant an overall strengthening of the judicial branch vis-à-vis the other branches of government. And the ingenious nature of Article 177 ensured that national courts did not feel that the empowerment of the European Court of Justice was at their expense. See J. Weiler, 'Transformation of Europe', *Yale Law Journal* (1991), p. 2426.

<sup>884</sup> *ibid.*, p. 2418.

EU law,<sup>885</sup> compensating for the inherent weaknesses in the centralized infringement procedure, and forging a more direct and intimate relationship between the citizens and EU law compared to international law. Strikingly, this relationship becomes mediated by national courts, rather than states or governments. The PRP allowed many salient questions to arrive at the Court (or they could be reinterpreted as such), which the Court could use as an opportunity to further flesh out the features of the EU legal order, without this becoming as structurally politicized as it might have been through the vehicle of the centralized enforcement procedure.<sup>886</sup>

How can the responsiveness of national courts to these far-reaching implications be explained? After all, even if it is impossible to establish exactly how faithfully national courts applied the foundational doctrines in practice in the years after their rendering, preliminary questions continued to be referred. This in itself, at least partially, served to consolidate these foundational doctrines, and it allowed others to be developed in suit. It is the very ingenuity of the PRP itself that is considered to be one of the crucial factors in explaining the receptiveness of especially lower national courts. Many will argue that it was, at least in part, about jurisdictional self-empowerment.<sup>887</sup> The de facto power of judicial review for national courts emanating from *Van Gend en Loos*, *Costa v ENEL* and *Simmenthal* empowered them vis-à-vis national political institutions and gave them powers that they might not have had before, all through the PRP vehicle.

Higher courts, on the other hand, were less receptive, which can in part be explained by the fact that some of the empowerment of the CJEU and the lower national courts by the PRP and the doctrines of direct effect and primacy was at their expense. Not only did higher courts have to 'share' certain jurisdictional privileges with lower courts, but the latter could even bypass the former referring directly to the CJEU to challenge the former's case-law, fundamentally upsetting national judicial hierarchies.<sup>888</sup> Indeed, many higher courts took a very long time to participate in the PRP,<sup>889</sup> and developed counter-doctrines that placed caveats and limitations on the doctrines of primacy and

---

<sup>885</sup> See on this generally M. Broberg, 'Preliminary References as a Means for Enforcing EU Law' in A. Jakab and D. Kochenov (eds.), *The Enforcement of EU Law and Values: Ensuring Member States' Compliance*, OUP (2017), p. 44.

<sup>886</sup> National governments provide observations in the PRP but this is different from a MS being a direct respondent, which implies a much different type of engagement with the questions and their legal and political implications.

<sup>887</sup> See n.10, K. Alter, "Explaining national courts' acceptance of European Court jurisprudence: A critical evaluation of theories of legal integration", in Slaughter et al. (eds.), *The European Court and National Courts – Doctrine and Jurisprudence: Legal Change in its Social Context*, Northwestern University Press (1998).

<sup>888</sup> D. Piqani, 'The Simmenthal Revolution Revisited; What Role for Constitutional Courts?' in B De Witte et al. (eds.), *National Courts and EU Law. New Issues, Theories and Methods*, Edward Elgar (2016), p. 26; M. Bobek, 'The Impact of the European Mandate of Ordinary Courts on the Position of Constitutional Courts' in M Claes et al. (eds.), *Constitutional Conversations in Europe: Actors, Topics and Procedures*, Intersentia, (2012), p. 287; J. Komarek, In the Court(s) We Trust? On the Need for Hierarchy and Differentiation in the Preliminary Ruling Procedure, *European Law Review*, 32(4) (2007), p. 467.

<sup>889</sup> For instance, the French Conseil constitutionnel submitted a preliminary reference to the CJEU for the first time in 2013 (Judgment of 30 May 2013, Case C-168/13 PPU, *Jeremy F*, ECLI:EU:C:2013:358), the German Constitutional Court in 2014 (BVerfG, Order of the Second Senate of 14 January 2014 - 2 BvR 2728/13, ECLI:DE:BVerfG:2014:rs20140114.2bvr272813), the Portuguese Constitutional Court only in 2020.

(to a much lesser extent) direct effect.<sup>890</sup> In the following years, some of this resistance was abandoned,<sup>891</sup> some of it mutated,<sup>892</sup> and some of it has been (re-)asserted later.<sup>893</sup>

### 3.2 Outright rejections to apply a preliminary ruling

The past decade has witnessed a certain escalation of the formerly largely theoretical, or indirect, conflict between the EU and national conceptions of final (judicial) authority. Various high courts, from various Member States, have outright rejected the authority of EU law in a specific instance, by refusing to apply a preliminary ruling by the CJEU.

In *Slovak Pensions* (2012), the Czech Constitutional Court refused to apply the CJEU ruling in *Landtová*.<sup>894</sup> The Czech Constitutional Court argued that pensions accrued in Slovakia before the dissolution of Czechoslovakia were not 'foreign pensions' in the sense of EU social security coordination contrary to the CJEU's judgment and that the CJEU's ruling was ultra vires in relation to the national constitution. In *Ajos* (2016), the Danish Supreme Court refused to apply the preliminary ruling of the CJEU in *Dansk Industri*.<sup>895</sup> At issue was the application of the CJEU's *Mangold*<sup>896</sup> doctrine that gives horizontal direct effect to the general principle of non-discrimination on grounds of age, 'against' a private employer. The Danish Supreme Court found this irreconcilable with the Danish Constitution, legal certainty and legitimate expectations. The German Constitutional Court's (GCC) *PSPP* judgment (2020) concerned bond-buying by the ECB, challenged before the GCC, who referred a preliminary reference to the CJEU (*Weiss*).<sup>897</sup> The CJEU held that the ECB has acted within its competence. The GCC instead considered the judgment of the CJEU ultra vires as it did not conduct a thorough proportionality review (which should include an assessment of effects on other policy areas), and thus considered itself not bound by the ruling. The GCC conducted its own assessment and considered that the ECB needed to conduct a proportionality assessment of the economic effects of its monetary policy.

In 2021, the Polish Constitutional Tribunal rendered a ruling that stated that EU law in so far as it (i) goes outside the competences conferred on it by Poland through the Treaties, (ii) would displace the Polish Constitution as the supreme law of Poland, and (iii) prevents Poland from functioning as a sovereign and democratic state, is incompatible with the Constitution. Specifically, it does not allow lower national courts

---

<sup>890</sup> The Semoules and Cohn-Bendit judgments of the Conseil d'Etat, the Solange I and Maastricht rulings of the Bundesverfassungsgericht, the Frontini judgment by the Italian Constitutional Court, and the Danish Constitutional Court's judgment in the Carlsen case are all well-known examples of national courts' refusal to accept the ECJ's case-law, especially its claims to supremacy and ultimate authority.

<sup>891</sup> Cour de Cassation (France) of 23 May 1975, *Jacques Vabre*; Conseil d'Etat (France) of 20 October 1989, *Nicolo*.

<sup>892</sup> For instance, Corte costituzionale (Italy) of 8 June 1984, Case No 170/1984, *Granital*, ECLI:IT:COST:1984:170.

<sup>893</sup> For instance Belgian Constitutional Court of 18 November 2010, Case No 130/2010. See for an overview M. Claes and J. Reestman, 'The Protection of National Constitutional Identity and the Limits of European Integration at the Occasion of the Gauweiler Case', *German Law Journal* 16(4) (2015), p. 917.

<sup>894</sup> Judgment of 22 June 2011, Case C-399/09, *Landtová*, ECLI:EU:C:2011:111.

<sup>895</sup> Judgment of 19 April 2016, Case C-441/14, *Dansk Industri*, ECLI:EU:C:2016:278.

<sup>896</sup> Judgment of 22 November 2005, Case C-144/04, *Werner Mangold*, ECLI:EU:C:2005:709.

<sup>897</sup> Judgment of 11 December 2018, Case C-493/17, *Weiss*, ECLI:EU:C:2018:1000.

to overrule, bypass or disapply the rulings of the Supreme Court, especially concerning the national organisation of justice. In the same year, the Romanian Constitutional Court, in reply to the CJEU ruling on a Special Prosecutor's office,<sup>898</sup> held that primacy accorded to EU law is limited in the Romanian legal order by the requirement of respect for national constitutional identity, and the Constitutional Court had to ensure the supremacy of the Romanian Constitution on Romanian territory. Consequently, it denied ordinary courts' jurisdiction to examine the conformity with EU law of a national provision which has been found to comply with Article 148 of the Romanian Constitution (the provision governing the primacy of EU law in the national constitution) by the Constitutional Court. The Constitutional Court declared unfounded the Judgment of the CJEU on a Special Prosecutor's office in light of the Romanian Constitution.

### 3.3 How to understand the conflict<sup>o</sup>

As always, there are many specific factors that may explain these judgments in their context. Commentators have argued that the *Slovak Pensions* ruling was collateral damage in relation to an internal power struggle between the Supreme Administrative Court, the Constitutional Court and the government.<sup>899</sup> The *Ajos* ruling concerns the horizontal direct effect of general principles of law, a doctrine which has been criticized more generally in EU legal circles. The *PSPP* judgment may have to be analysed against the complicated background of the euro crisis,<sup>900</sup> or as a parting statement by the GCC President,<sup>901</sup> and the judgments from the Polish and Romanian courts respectively are at the heart of the rule of law conflict, and many would argue that this affects the credibility of these judgments.

Yet, although these judgments 'crossed the Rubicon' of outright conflict which to that point had been considered unlikely to happen, the underlying rejection of the

---

<sup>898</sup> Judgment of 18 May 2021, Joined cases C-83/19, C-127/19, C-195/19, C-291/19, C-355/19 and C-397/19, *Asociația 'Forumul Judecătorilor din România'*, ECLI:EU:C:2021:393.

<sup>o</sup> The position of the ECJ is that the direct effect and primacy of EU law is based on the nature of European Union law itself. One (...) interpretation would be that national courts have no choice and that they simply cannot resist the authority of EU law. The latter reading implies that national courts, when acting on the duties imposed on them by the ECJ, are exercising a jurisdiction attributed to them directly by Union law, and not a jurisdiction given to them by their own constitution. Many EU law scholars, particularly those of France and the Benelux countries, adopted this view, but there is hardly any evidence of national courts adopting this radical approach. National courts rather see themselves as organs of their state, and try to fit their European mandate within the framework of the powers attributed to them by their national legal system. For them (and, indeed, for most constitutional law scholars throughout Europe), the idea that EU law can claim its primacy within the national legal orders on the basis of its own authority seems as implausible as Baron von Munchhausen's claim that he had lifted himself from the quicksand by pulling on his bootstraps. The national courts (with the possible exception of those of the Netherlands) see EU law as rooted in their constitution and seek a foundation for the primacy and direct effect of EU law in that constitution. See B. de Witte, 'Direct effect, primacy and the nature of the legal order' in P. Craig and G. de Búrca, *The Evolution of EU Law*, OUP (2021), p. 216.

<sup>899</sup> J. Komarek, 'Czech Constitutional Court Playing with Matches: the Czech Constitutional Court Declares a Judgment of the Court of Justice of the EU Ultra Vires; Judgment of 31 January 2012, Pl. ÚS 5/12, *Slovak Pensions XVII*', *European Constitutional Law Review*, 8(2) (2012), p. 323.

<sup>900</sup> A. Bobic and M. Dawson, 'Making sense of the "incomprehensible": The PSPP Judgment of the German Federal Constitutional Court', *Common Market Law Review*, 57(6) (2020), p. 1953.

<sup>901</sup> As Euractiv predicted shortly before the ruling: 'if lead judge Voskuhle hopes to go out with a bang before his last day in office on Wednesday, now could be his moment'. <https://www.euractiv.com/section/economy-jobs/news/top-german-judges-to-rule-on-massive-ecb-economic-support/>

'constitutional claim' as developed in the foundational rulings is not new, and it is this that allows these courts to take the step of outright confrontation. Although each jurisdiction has its own approach in this regard, there is a red thread, that binds the position of all (but one – the Netherlands<sup>902</sup>) national constitutional/supreme courts: they reject that the EU's authority is sourced autonomously by the Treaties as interpreted by the CJEU and instead "see EU law as rooted in their constitution and seek a foundation for the primacy and direct effect of EU law in that constitution"<sup>903</sup>. This implies that ultimately the national Constitution – as interpreted by the competent national court – conditions the authority/application of EU law in the national legal order, and crucially – for not all but certainly some of them – not only on the occasion of the ratification of a new Treaty, but also in the exercise of EU authority on the basis of the existing Treaty framework.

One way to approach the above-mentioned national rulings is to consider them illegal. As the CJEU reiterated recently in *RS* in reaction to the Romanian ruling, a judgment delivered in the context of the PRP is binding on the national court as regards the interpretation of EU law for the purposes of resolving the dispute before it.<sup>904</sup> In this spirit, the European Commission launched infringement proceedings against Germany following the *PSPP* ruling of the GCC, considering "that the German Court deprived a judgment of the European Court of Justice of its legal effect in Germany, breaching the principle of the primacy of EU law" and that this judgment in itself "constitutes a serious precedent, both for the future practice of the German Constitutional court itself, and for the supreme and constitutional courts and tribunals of other Member States".<sup>905</sup> It closed these proceedings only after receiving from the German government a firm commitment to the primacy of EU law.<sup>906</sup>

Yet, such an approach sits uneasily with the unsettled nature of primacy in the compound EU constitutional order. Primacy has not been codified. After an attempt to prominently include it (albeit still ambiguously worded) in the Constitutional Treaty failed, it was relegated to a non-binding declaration. The CJEU has recently stated that when the Lisbon Treaty was adopted, "the conference of representatives of the governments of the Member States was keen to state expressly, in its Declaration No 17 concerning primacy [...] that in accordance with settled case-law of the Court, the Treaties and the law adopted by the Union on the basis of the Treaties have primacy over the law of the Member States, under the conditions laid down by that case-law".<sup>907</sup> The non-binding Declaration that replaced the actual codification attempt does, indeed, contrary to the primacy clause in the Constitutional Treaty, refer to the Court's case-law. This stands in stark contrast however to the legal status of

---

<sup>902</sup> See L. Besselink and M. Claes, 'The Netherlands: The Pragmatics of a Flexible, Europeanised Constitution' in A Albi and S Bardutzky (eds.), *National Constitutions in European and Global Governance: Democracy, Rights, the Rule of Law*, TMC Asser Press (2019), p. 191.

<sup>903</sup> B. de Witte, 'Direct effect, primacy and the nature of the legal order' in P. Craig and G. de Búrca, *The Evolution of EU Law*, OUP (2021), p. 216.

<sup>904</sup> Judgment of 22 February 2022, Case C-430/21, *RS*, ECLI:EU:C:2022:99.

<sup>905</sup> European Commission, press release, [https://ec.europa.eu/commission/presscorner/detail/en/inf\\_21\\_2743](https://ec.europa.eu/commission/presscorner/detail/en/inf_21_2743).

<sup>906</sup> European Commission, press release, [https://ec.europa.eu/commission/presscorner/detail/en/inf\\_21\\_6201](https://ec.europa.eu/commission/presscorner/detail/en/inf_21_6201).

<sup>907</sup> Judgment of 21 December 2021, Joined cases C-357/19, C-379/19, C-547/19, C-811/19 and C-840/19, *Euro Box Promotion and Others*, ECLI:EU:C:2021:1034.



this Declaration, which is formally naught. The ‘keenness’ referred to by the Court on the part of the drafters may instead be understood as a concern to prevent the remarkable removal of primacy from the Lisbon Treaty – which on all other important substantive legal matters copied the Constitutional Treaty – as being interpreted as an outright rejection of it.

What was (ever more) prominently included in the Lisbon Treaty was the many iterations of the principle of conferral, expressing the idea that the EU’s powers are not autonomous and a priori unlimited but instead circumscribed and conditional, ultimately belonging to the Member States, as well as the EU’s obligation to respect “national identities, inherent in Member States’ fundamental structures, political and constitutional”. And regardless of the text of the Treaties, upon the view of many of the national constitutional orders of the Member States, it would be impossible to accept the full ‘constitutional claim’ to final authority as proclaimed in the foundational rulings within their current constitutional frameworks – the alternative would be to find a truly Constitutional (re-)settlement at EU level.

The most important, yet oftentimes overlooked, piece of the primacy puzzle is that of popular sovereignty. In any constitutional democracy, in any legitimate polity, authority is sourced by the People (in a Federal system the compound People(s)). Yet the question of primacy, or where final authority lies, has not been explicitly decided by the People(s) of Europe: the experience of the Constitutional Treaty should not be taken as a conclusive rejection but neither can the Lisbon Treaty be taken as anything close to acceptance.<sup>908</sup> Until we finally procure a deliberated decision by a sufficiently mobilized European People(s) on this issue, we cannot consider the EU’s constitutional claim as settled, and instead – as many scholars have argued over the years – we live in a state of constitutional pluralism.<sup>909</sup>

## 4 The PRP in the context of the pluralism of the compound European constitutional order

### 4.1 Constitutional pluralism and the PRP

Faced with the reality of competing claims to constitutional authority, many scholars have argued that this pluralism needs to be accepted (and perhaps even welcomed), as it befits the specific nature of the compound and diverse European legal order. The PRP takes a central place in this approach. Judicial openness, dialogue and cooperation are generally considered the best way to, on the one hand, reap the benefits of such pluralism (mutual learning, increased quality of reasoning, better legal outcomes) and on the other hand mitigate the possible negative consequences

---

<sup>908</sup> See further S. Garben, ‘The constitutionalization of European integration as a single, protracted ‘constitutional moment’ towards the establishment of EU final authority’ in M. Dani, M. Goldoni and A.J. Menéndez, *The Legitimacy of European Constitutional Orders*, Edward Elgar (2024), pp. 259–281.

<sup>909</sup> See generally N. MacCormick, *Questioning Sovereignty*, OUP (1999); N. Walker (ed), *Sovereignty in Transition*, Hart (2003); N. Walker, ‘Constitutional Pluralism Revisited’ (2016) 22 *European Law Journal* 333. For a collection of (sometimes contrasting) views on constitutional pluralism: M. Avbelj and J. Komarek (eds.), *Constitutional Pluralism in the European Union and Beyond*, Hart (2012).

(escalation, contradiction, legal uncertainty) – and the PRP is the vehicle for such dialogue.

The *Taricco* saga is often considered to be a good example thereof.<sup>910</sup> In a preliminary ruling the CJEU had initially held that the provisions of the Italian Criminal Code, in so far as they provided that the interruption of criminal proceedings concerning serious fraud in relation to Value Added Tax (VAT) had the effect of extending the limitation period by only a quarter of its initial duration, were liable to have an adverse effect on the fulfilment of the Member States' obligations under Article 325(1) and (2) TFEU if those national rules prevent the imposition of effective and dissuasive penalties in a significant number of cases of serious fraud affecting the financial interests of the EU and that the national court had to give full effect to Article 325(1) and (2) TFEU, if need be by disapplying the provisions of national law.<sup>911</sup> The Italian Constitutional Court considered this may be contrary to its own Constitutional principles and used the PRP to invite the CJEU to revisit its approach in *Taricco I*, by identifying possible ways to 'clarify' that prior ruling. The CJEU accepted the invitation, concluding that if "the national court were thus to come to the view that the obligation to disapply the provisions of the Criminal Code at issue conflicts with the principle that offences and penalties must be defined by law, it would not be obliged to comply with that obligation, even if compliance with the obligation allowed a national situation incompatible with EU law to be remedied [...]. It will then be for the national legislature to take the necessary measures".<sup>912</sup>

The *Taricco* example shows that through constructive judicial dialogue between national courts and the CJEU a win-win can be created, where outright conflicts can be avoided or resolved, and the legal order can thrive precisely because of the pluralistic approach. The dialogue resulted in a solution that was acceptable to all: no impunity for Italy since the legislator remained responsible, but national courts not required to act contrary to a fundamental principle of their constitution, which was ultimately a value also protected at EU level.

The crucial importance of a well-functioning PRP to successfully accommodate constitutional pluralism is illustrated by the fact that several of the aforementioned cases of outright conflict have been attributed to a preventable failure of dialogue via the PRP. Elkan and others argue with respect to *Ajos* that "the judgments of the ECJ and of the Danish Supreme Court are both legally sound and understandable when read from each courts' legal perspective" but that "regrettably, both courts failed in carrying out a judicial dialogue in the spirit of good faith", as "instead, the preliminary reference procedure was used in a way that gradually built up tensions and ended in a clear clash".<sup>913</sup> Komarek has described in relation to *Slovak Pensions* how the Czech Constitutional Court apparently misunderstood the PRP, as instead of referring a preliminary question it sent a letter to the CJEU wanting to explain its case-law in the context of the *Landtová* case – and was then deeply insulted when in accordance

---

<sup>910</sup> See e.g. M. Bonelli, 'The Taricco Saga and the Consolidation of Judicial Dialogue in the European Union' (2018) *Maastricht Journal of European and Comparative Law* 25, p. 357.

<sup>911</sup> Judgment of 8 September 2015, Case C-105/14, *Taricco*, ECLI:EU:C:2015:293.

<sup>912</sup> Judgment of 5 December 2017, Case C-42/17, *M.A.S. and M.B. (Taricco II)*, ECLI:EU:C:2017:936.

<sup>913</sup> D. Elkan, R. Holdgaard, G. Krohn Schaldemose, From cooperation to collision: The ECJ's *Ajos* ruling and the Danish Supreme Court's refusal to comply, *Common Market Law Review* 55(1) (2018), p. 17.

with the rules of procedure the letter was sent back by the Registry of the CJEU.<sup>914</sup> Tuori has framed the longstanding contradiction between the GCC and the CJEU as open to both a “pronouncedly conflictual account, where the emphasis lies on successive efforts to enhance the jurisdictional authority of the respective courts” as well as a ‘dialogical version’ which takes note of “assurances of readiness for sincere cooperation and respect for viewpoints embraced by the interlocutor, as well as references to normative and methodological common ground” and that recounts “a cooperative search for comprehensive fundamental rights protection in European legal and constitutional space”.<sup>915</sup> The *PSPP* ruling is certainly a more conflictual episode in the story.

Recently, concerns about the rule of law in – inter alia – Hungary, Poland and Romania have spurred criticism of the constitutional pluralism-approach, with the judgement of the Polish Constitutional Tribunal denouncing the primacy of EU law used as an example of the consequences of allowing challenges to the supremacy of EU law.<sup>916</sup> However, it is important to separate the rule of law conflict from the legitimate contestation by national courts of certain hierarchical implications of the EU judicial order as outlined in the case-law. It is unfortunate that concerns about the rule of law and judicial independence in the Member States on the one hand, and contestation of the final source of EU authority on the other hand, become perceived as mutually exclusive. What matters, ultimately, is the legitimacy of the exercise of authority on the basis of the principles of democracy and constitutionalism – the latter comprising the rule of law and fundamental rights. On those grounds, there are of course legitimate reasons to be critical of the (reforms of the) judicial systems in inter alia Poland and Romania. But not because their higher courts reject the final authority of EU law – all (but one) national constitutional systems do so. And with reasons precisely grounded in the principles of democracy and constitutionalism. Not only is it unlikely that the rule of law conflict can be resolved through the enforcement of absolute primacy through the PRP, it would furthermore be inappropriate to use the rule of law conflict to enforce absolute primacy on all higher national courts. These matters should thus be distinguished and kept separate.

## 4.2 The PRP and the uniformity of the interpretation of EU law

The complication in a re-conception of the PRP as a platform for constitutional pluralism is the quest for the uniformity of the interpretation of EU law, which from the very beginning has been conceived by the CJEU as its main purpose. In *Van Gend en Loos*, the Court stated that “the task assigned to the Court of Justice under Article 177 [the PRP], the object of which is to secure uniform interpretation of the Treaty by national courts and tribunals”, and it has repeated this on countless occasions. An important recent restatement can be found in *RS*. “[The PRP], which is the keystone

<sup>914</sup> J. Komarek, *Playing With Matches: The Czech Constitutional Court's Ultra Vires Revolution*, <https://verfassungsblog.de/playing-matches-czech-constitutional-courts-ultra-vires-revolution/>.

<sup>915</sup> K. Tuori, ‘From pluralism to perspectivism’ in G. Davies & M. Avbelj (eds.), *Research Handbook on Legal Pluralism and EU Law*, Edward Edgar (2018), p. 50.

<sup>916</sup> D. Kelemen and L.t Pech, ‘The Uses and Abuses of Constitutional Pluralism: Undermining the Rule of Law in the Name of Constitutional Identity in Hungary and Poland’ (2019) *Cambridge Yearbook of European Legal Studies*, 21, p. 59.

of the judicial system established by the Treaties, sets up a dialogue between one court and another, specifically between the Court of Justice and the courts of the Member States, having the object of securing uniform interpretation of EU law, thereby serving to ensure its consistency, its full effect and its autonomy as well as, ultimately, the particular nature of the law established by the Treaties.”<sup>917</sup>

If complete uniformity is the core objective, then from that flows logically that the CJEU is to have the last word in all cases and should be asked in all cases. But why is the uniformity of EU law so important? Is it because, “any weakening, even if only potential, of the uniform application and interpretation of Community law throughout the Union would be liable to give rise to distortions of competition and discrimination between economic operators, thus jeopardizing equality of opportunity as between those operators and consequently the proper functioning of the internal market”?<sup>918</sup> Is it because of the equality between the Member States, as “respect for the equality of Member States before the Treaties [...] precludes the possibility of relying on, as against the EU legal order, a unilateral measure, whatever its nature”?<sup>919</sup>

No legal system aims at, or achieves, full ‘uniformity’<sup>920</sup> in the judicial interpretation and application of the law. Ideally, a mature highest court will provide sufficiently clear steer on crucial points of legal principle that ensures a necessary degree of coherence and equality across the system, without the illusion that this eliminates all differences and settles all discord. In fact, the EU legal order allows itself a great deal of differentiation, through a variety of opt-outs and derogations in both primacy and secondary law, through minimum harmonisation measures, as well as through the texture of the Court’s case-law especially in the internal market through its wide conception of *prima facie* restrictions of free movement (potentially capturing all rules on economic activity) and its open-ended (and unpredictable) approach to justification thereof. Furthermore, despite the structural and procedural implications of primacy, there remains a great deal of national procedural divergence, and – perhaps under the radar – a great deal of opportunity for national courts to side-step or avoid EU law simply through the way they choose to solve the case before them.

Perhaps one would be tempted to argue that precisely because of this differentiation and diversity, there should be a strong insistence on legal uniformity in the PRP. But at a more fundamental level, the normative claim that would justify such uniformity in the first place is unsettled. The EU’s claim to final authority has not been decided by the only legitimate source of that authority: the People(s) of Europe. Until that time, it would seem that an approach to the PRP that facilitates constitutional pluralism, rather than forces a uniform acceptance of EU primacy, is the most legitimate way forward.

---

<sup>917</sup> Judgment of 22 February 2022, Case C-430/21, *RS*, ECLI:EU:C:2022:99, para. 73.

<sup>918</sup> Report of the Court of Justice on certain aspects of the application of the Treaty on European Union, 1995, point 11.

<sup>919</sup> Judgment of 22 February 2022, Case C-430/21, *RS*, ECLI:EU:C:2022:99.

<sup>920</sup> See for an extensive discussion of this J. Komarek, In the Court(s) We Trust? On the Need for Hierarchy and Differentiation in the Preliminary Ruling Procedure, *European Law Review*, 32(4) (2007), p. 467.

#### 4.3 Towards 'unity in diversity' in the PRP in a spirit of mutual judicial trust?

What is crucial in ensuring that the EU legal system works well is that (i) there is a degree of trust between the judicial actors, that (ii) judicial dialogue on the one hand avoids outright clashes as much as possible and on the other hand leads to improved legal outcomes thanks to mutual learning and understanding, and that (iii) national courts want to use EU law as part of their own legal system to provide good legal solutions to real legal problems.

Van Gestel and De Poorter soberingly find that with regard to Supreme Administrative Courts and the CJEU "[d]rawing up the balance from the literature, case law, and interviews, one must conclude the communication between courts in the preliminary reference procedure does not represent a dialogue going (much) beyond one side asking questions, while the other side tries to answers them. Procedural mechanisms [...] that could enhance cooperation and communication are scarcely used to facilitate co-actorship. There are not only practical reasons for this. The lack of dialogue also partly results from a lack of faith in each other's competence, reliability, and intentions."<sup>921</sup>

There may be some valid reasons for the lack of trust on both sides, but something will have to be done to move beyond it.

It would seem that at least partially, the difficult relationship between the CJEU and national highest course is that the latter's authority has been displaced: not only by making EU law the highest law of their land but by allowing lower courts to bypass and challenge them. Perhaps the dialogue would be improved if the status of highest national courts in the EU judicial order would be reinforced.

One far-reaching way would be to restore internal judicial hierarchies, by limiting preliminary references on the interpretation (not validity) of EU law to the highest courts, as proposed by Komarek.<sup>922</sup> Another way would be to establish a new, separate procedure for constitutional dialogue between (members of) the highest national courts and the CJEU. Weiler and Sarmiento have proposed the creation of a separate chamber at the CJEU for similar purposes.<sup>923</sup>

Admittedly, there seems little appetite for a reform in this direction at the CJEU. Advocate General Bobek<sup>924</sup> made an altogether modest proposal to revisit the PRP, that would have provided a bit more autonomy to courts of last instance and would have relieved the Court's workload.<sup>925</sup> It was not followed by the Court. The CJEU has

---

<sup>921</sup> R. van Gestel and J. de Poorter, Trust and Dialogue in *In the Court We Trust - Cooperation, Coordination and Collaboration between the ECJ and Supreme Administrative Courts*, CUP (2019).

<sup>922</sup> J. Komarek, In the Court(s) We Trust? On the Need for Hierarchy and Differentiation in the Preliminary Ruling Procedure, *European Law Review*, 32(4) (2007), p. 467.

<sup>923</sup> J. Weiler and D. Sarmiento, The EU Judiciary After Weiss – Proposing a New Mixed Chamber of the Court of Justice, <https://eulawlive.com/app/uploads/j-h-h-weiler-and-daniel-sarmiento.pdf>.

<sup>924</sup> Opinion of AG Bobek on 15 April 2021, Case C-561/19, *Consorzio Italian Management*, ECLI:EU:C:2021:291.

<sup>925</sup> There would only be an obligation to refer if the case raises a general issue of interpretation of EU law, there may reasonably be more than one interpretation and it cannot be inferred from the case law of the CJEU.

instead proposed to solve its case overload by transferring part of its jurisdiction to give preliminary rulings to the General Court – which will do nothing to address the more profound challenges of the PRP as set out in the foregoing.

## 5 Conclusion

If the PRP did not exist, it would have to be invented. Fortunately it does, but this should not prevent us from reinventing it, to better suit the needs of our constitutionally complicated compound legal order – in which the PRP sits at the very heart. This chapter has argued that there are good reasons to reconsider the hierarchical organisation of the EU judicial order in favour of a more heterarchical approach: to forego a degree of (the pursuit of) ‘uniformity’ in favour of ‘unity in diversity’.<sup>926</sup> Reforms of the PRP that would give the highest national courts pride and place in the EU judicial system, would be likely to improve the quality of dialogue and trust, and would do justice to the unsettled nature of the EU’s final authority claim.

---

<sup>926</sup> Echoing in this regard: J. Komarek, In the Court(s) We Trust? On the Need for Hierarchy and Differentiation in the Preliminary Ruling Procedure, *European Law Review*, 32(4) (2007), p. 467.

# Developments of the preliminary reference procedure in a historical perspective

Vittorio Di Bucci\*

## 1 Preliminary rulings: their development and their acceptance

In her chapter, Professor Garben has dealt with the historical development of preliminary references. In the first part of my contribution, I would like to present, in a very concise manner, a different view of the way this tool has been used by the Court of Justice of the European Union (CJEU) over six decades, and of the reactions that the Court's case-law has elicited.

### 1.1 The preliminary reference as a flexible instrument, developed through judicial cooperation

Over the years, this instrument has shown to be extremely flexible and versatile, and, contrary to what is often claimed, the way the Court has dealt with it was widely accepted.

It is well-known that the initial intention in the European Coal and Steel Community (ECSC) Treaty was to complement other remedies available against the Community institutions by allowing national courts to send to the Court of Justice references for validity (only)<sup>927</sup>. The drafters of the Rome Treaties went a very considerable step further by establishing references on interpretation of Community law as an instrument to ensure uniform interpretation and application of European Union (EU) law. This remarkable innovation allowed the Court of Justice to perform a number of different functions when replying to preliminary references: (i) assessing (indirectly) the compatibility of national rules with EU law, (ii) establishing the constitutional foundations of the EU legal order, (iii) clarifying the respective competences of the EU and of the Member States, (iv) laying down requirements on national legal orders and national judiciaries and, importantly, (vi) protecting fundamental rights not only vis-à-vis EU institutions, but also vis-à-vis Member States when the latter act within the scope of the EU Treaties. Preliminary references thus became the essential tool to build a European legal order.

---

\* Registrar at the General Court of the European Union. All views expressed reflect the personal opinions of the author

<sup>927</sup> The Court first held that it had jurisdiction to rule on references for interpretation under the ECSC Treaty in Case C-221/88, *Acciaierie e Ferriere Busseni*, ECLI:EU:C:1990:84.

This expansive reading of Article 267 Treaty on the Functioning of the European Union (TFEU) was made possible by an intensive and fruitful dialogue with national courts. Only the latter, of course, could ask the Court of Justice to rule on their questions and were therefore at the origin of all these developments, but in most cases they went further: they also invited the Court to choose, or at least to consider, an expansive reading of the scope of the procedure for preliminary references. In all but very few cases, they also accepted to follow the approach and the interpretation provided by the Court, or even encouraged further steps by asking additional questions.

## 1.2 Acceptance by the Member States

A second aspect that it is worth to underline is that, in a large number of cases, the so-called *Herren der Verträge*, namely the Member States, expressly or at least implicitly accepted and confirmed these developments when amending the Treaties. In particular, Article 19(1) Treaty on European Union (TEU), when providing that “Member States shall provide remedies sufficient to ensure effective legal protection in the fields covered by Union law”, draws the lessons of judgments such as: (i) *Rewe*<sup>928</sup> and *San Giorgio*<sup>929</sup> on the principles of effectiveness and equivalence of national remedies, (ii) *Factortame I*<sup>930</sup> on interim measures, or (iii) *Francovich*<sup>931</sup> and *Brasserie du Pêcheur and Factortame II*<sup>932</sup> on state liability for violations of Community law. Article 51(1) of the Charter of Fundamental Rights, specifying that Member States shall respect the rights, observes the principles and promote the application of the provisions of the Charter when they are implementing EU law, and it embraces the Court’s approach in judgments like *Wachauf*<sup>933</sup> and *ERT*<sup>934</sup>, as expressly stated in the official Explanations of the Charter. Declaration No 17 concerning primacy confirms the “well settled case law of the Court of Justice”, and even quotes an excerpt of a note of the Council Legal Service on the *Costa v ENEL* judgment<sup>935</sup>, where the latter is defined as “a cornerstone principle of Community law”. The fact that such support for primacy is to be found in a declaration, rather than in a provision of the Treaty, does not detract from its strong significance – not only political but eminently legal – even if one were to apply the international law principles concerning the interpretation of treaties, as expressed in Articles 31(2)(b)<sup>936</sup> and (3)(b)<sup>937</sup> of the Vienna Convention on the Law of Treaties.

---

<sup>928</sup> Case 33-76, *Rewe-Zentralfinanz*, ECLI:EU:C:1976:188.

<sup>929</sup> Case 199/82, *San Giorgio*, ECLI:EU:C:1983:318.

<sup>930</sup> Case C-213/89, *Factortame*, ECLI:EU:C:1990:257.

<sup>931</sup> Joined cases C-6/90 and C-9/90, *Francovich and Bonifaci*, ECLI:EU:C:1991:428.

<sup>932</sup> Joined cases C-46/93 and C-48/93, *Brasserie du Pêcheur and Factortame*, ECLI:EU:C:1996:79.

<sup>933</sup> Case 5/88, *Wachauf*, ECLI:EU:C:1989:321.

<sup>934</sup> Case C-260/89, *Elliniki Radiophonia Tiléorassi and Others*, ECLI:EU:C:1991:254.

<sup>935</sup> Case 6-64, *Costa v ENEL*, ECLI:EU:C:1964:66.

<sup>936</sup> Articles 31(2)(b) states as follows: “2. The context for the purpose of the interpretation of a treaty shall comprise, in addition to the text, including its preamble and annexes: [...] (b) any instrument which was made by one or more parties in connection with the conclusion of the treaty and accepted by the other parties as an instrument related to the treaty”.

<sup>937</sup> Articles 31(3)(b) states as follows: “3. There shall be taken into account, together with the context: [...] (b) any subsequent practice in the application of the treaty which establishes the agreement of the parties regarding its interpretation; [...]”.



Even protocols that are – or rather were – aimed at limiting certain possible effects of the Court’s case-law, like Protocol No 33 on the *Barber* judgment<sup>938</sup> or Protocol No 35 on abortion in Ireland after *Grogan*<sup>939</sup>, did not put into question the judgments themselves. Moreover, they were obviously based on the premise that the Court’s interpretation in a preliminary ruling can normally be relied upon to prevent the application of conflicting national rules; in other words, they took primacy for granted. This, again, shows that Member States, even when they were concerned with specific elements of the case-law of the Court of Justice, never put into question the primacy of EU law and the binding character of the Court’s preliminary rulings.

### 1.3 Limited or unsuccessful rebellions and fruitful dialogue

Certainly, some clashes with some national supreme or constitutional courts should not be ignored. At this juncture, we should leave aside objections to preliminary rulings, or to the principles of primacy and direct effect, that were raised decades ago by certain national courts and were subsequently abandoned or redefined to establish a mutually satisfactory *modus vivendi* between those courts and the Court of Justice. Of course, national courts, and in particular constitutional courts, will rely on their constitution to find a basis for primacy and direct effect of EU law, and this will inevitably create tensions in the very few cases where a direct conflict appears between EU law and national constitutional provisions. Even in such exceptional situations, as shown below, a solution may be found case by case in a constructive judicial dialogue.

One should rather focus on more recent episodes of outright rebellion vis-à-vis the Court of Justice, such as the rejection by the Czech Constitutional Court in 2012 of the *Landtová* judgment of the CJEU on “Slovak pensions”<sup>940</sup>, the Danish Supreme Court’s refusal to follow the CJEU in the *Ajos* Case<sup>941</sup>, the *Weiss* judgment of the German Constitutional Court and the ongoing confrontations between the Romanian Constitutional Court<sup>942</sup> and the Polish Constitutional Court<sup>943</sup>, on the one hand, and the Court of Justice, on the other hand.

However, a closer look at those judicial decisions shows that they constitute quite exceptional occurrences, that they concern a tiny minority of Member States, that they are extremely heterogeneous and that, with the possible exception of the Polish and Romanian situation, they do not really put into question the fundamental features of the EU’s constitutional order.

---

<sup>938</sup> Case C-262/88, *Barber*, ECLI:EU:C:1990:209.

<sup>939</sup> Case C-159/90, *Society for the Protection of Unborn Children Ireland*, ECLI:EU:C:1991:378.

<sup>940</sup> Czech Constitutional Court, *Holubec (Slovak Pensions XVII)*, Pl ÚS 5/12.

<sup>941</sup> Danish Supreme Court, Case No 15/2014, UfR 2017.824H; for an English translation see <https://domstol.dk/hoejesteret/decided-cases-eu-law/2016/12/the-relationship-between-eu-law-and-danish-law-in-a-case-concerning-a-salaried-employee/>.

<sup>942</sup> Romanian Constitutional Court, Case No 390/2021 (OJ No 612/2021).

<sup>943</sup> See, in particular, the rulings of the Polish Constitutional Court of 14 July 2021 (Case No P 7/20) and 7 October 2021 (Case No K 3/21).

Starting with the less recent cases, the Czech rebellion about Slovak pensions had little to do with the CJEU, and it was rather the outcome of a conflict between the Czech Constitutional Court and the Czech Supreme Administrative Court, which had referred the *Landtová* case. The conflict was ultimately solved in line with the interpretation provided by the Court of Justice.<sup>944</sup>

The Danish Supreme Court's refusal to apply the *Dansk Industri* judgment of the CJEU was, admittedly, a more serious incident, but it had a limited scope, putting into question only the so-called horizontal effect of general principles of EU law, and had no further consequences.

The *Weiss* judgment of the Constitutional Court in Karlsruhe was, of course, a much more conspicuous, indeed spectacular, act of rebellion and defiance vis-à-vis the CJEU, even though it only concerned a divergence on the standard of review of a specific, if important, act of the European Central Bank (ECB), namely the decision on the public sector asset purchase programme (PSPP). As to the merits of the judgment, it has already been shown that the attitude of the German Constitutional Court and its criticism of the way the Court of Justice had dealt with the control of proportionality was based on a misunderstanding of the rules on the allocation of competences between the Member States and the EU. In accordance with Article 5 TEU, proportionality is a crucial parameter for assessing the legality of the use of EU competences, but it plays no role in determining whether the EU institutions have been entrusted with such competences in accordance with the principles of conferral.<sup>945</sup> I would just add three remarks: first, the German constitutional judges met with harsh criticism across Europe, and perhaps unexpectedly, also in the German legal debate; second, the German Constitutional Court itself found, one year later, that there was no issue of competence after all, because the ECB had properly assessed the proportionality of the PSPP; and, third, the outcome of the infringement procedure launched by the European Commission was "nothing less than a complete disavowal of the [*Weiss*] judgment"<sup>946</sup> by the German government. The latter "formally declared that it affirms and recognises the principles of autonomy, primacy, effectiveness and uniform application of Union law"; it "explicitly recognise[d] the authority of the Court of Justice of the European Union, whose decisions are final and binding" and considered that "the legality of acts of Union institutions cannot be made subject to the examination of constitutional complaints before German courts but can only be reviewed by the Court of Justice"<sup>947</sup>. In other words, the German government unequivocally chose the side of the Luxembourg judges and expressly considered that their Karlsruhe counterparts had exceeded their competences. One could argue that, if the *Weiss* judgment provoked a constitutional crisis within the EU, it triggered an

---

<sup>944</sup> The Czech Supreme Administrative Court actually reacted to the judgment of the Constitutional Court by addressing a new reference to the CJEU in Case C-253/12, *JS*, ECLI:EU:T:2015:811. The reference was later withdrawn, because the Czech authorities had recognised the entitlement to a pension in accordance with the judgment of the Court of Justice.

<sup>945</sup> See, in particular, Lenaerts, K. (2022), "Proportionality as a matrix principle promoting the effectiveness of EU law and the legitimacy of EU action", in *Continuity and change – how the challenges of today prepare the ground for tomorrow – ECB Legal Conference 2021*, European Central Bank, p. 27.

<sup>946</sup> The quote is from a comment by Giegerich, T. (2021), "All's well that ends well? – European Commission closes infringement procedure against Germany on PSPP judgment of the Federal Constitutional Court", *Jean-Monnet-Saar*, available at [https://jean-monnet-saar.eu/?page\\_id=125638](https://jean-monnet-saar.eu/?page_id=125638).

<sup>947</sup> See European Commission (2021), 'December infringements package: key decisions', press release of 2 December 2021, available at [https://ec.europa.eu/commission/presscorner/detail/en/inf\\_21\\_6201](https://ec.europa.eu/commission/presscorner/detail/en/inf_21_6201).

even more serious one in Germany, which the drafters of that judgment may not have anticipated, and dealt a blow to the standing and reputation of the German Constitutional Court, rather than to the Court of Justice.

In 2021, the Romanian Constitutional Court refused to comply with a ruling of the Grand Chamber of the Court of Justice concerning requirements flowing from EU law as to the organisation of justice in Romania, the financial liability of the State and the personal liability of judges for the damage caused by a judicial error and – crucially – the power for any national court to disapply of its own motion a national provision which it considers contrary to EU law<sup>948</sup>. The Romanian Constitutional Court, on the contrary, found that, when it declares national legislation consistent with Article 148 of the Romanian Constitution that requires compliance with the principle of primacy of EU law, ordinary courts no longer have jurisdiction to examine the conformity of that legislation with EU law. This stance was immediately contested by the Court of Appeal of Craiova, which submitted a reference to the Court of Justice. The latter reacted first in its *Euro-Box* judgment<sup>949</sup>, dealing with previous references by the Romanian Supreme Court, and then in *RS*<sup>950</sup> and in further judgments<sup>951</sup>. The Court of Justice unsurprisingly reiterated its previous stance, going back to the *Simmenthal* judgment of 1978<sup>952</sup>, holding that EU law precludes national rules or a national practice under which the ordinary courts of a Member State have no jurisdiction to examine the compatibility with EU law of national legislation which the constitutional court of that Member State has found to be consistent with a national constitutional provision that requires compliance with the principle of the primacy of EU law. The Court of Justice further shielded the referring judges from disciplinary measures, adding that EU law precludes national rules or a national practice under which a national judge may incur disciplinary liability on the ground that he or she has applied EU law, as interpreted by the Court, thereby departing from case-law of the constitutional court of the Member State concerned that is incompatible with the principle of the primacy of EU law.

Finally, by its two judgments of 2021, the Constitutional Court of Poland chose an outright collision course with the Court of Justice, putting into question the principles of primacy, autonomy, effectiveness and uniform application of EU law. Without discussing the substantive issues, the legitimacy of the Polish Constitutional Court is highly doubtful and strongly contested even within Poland, because of irregularities in its composition,<sup>953</sup> in addition to the fact that its aggressive stance has found very little support outside Poland. Meanwhile, the European Commission has brought before the Court of Justice an infringement procedure against Poland in respect of these two judgments, now pending before the CJEU.<sup>954</sup>

---

<sup>948</sup> Joined Cases C-83/19, C-127/19, C-195/19, C-291/19, C-355/19 and C-397/19, *Asociația 'Forumul Judecătorilor din România' and Others*, ECLI:EU:C:2021:393.

<sup>949</sup> Joined Cases C-357/19, C-379/19, C-547/19, C-811/19 and C-840/19, *Euro Box Promotion and Others*, ECLI:EU:C:2021:1034.

<sup>950</sup> Case C-430/21, *RS*, ECLI:EU:C:2022:99.

<sup>951</sup> Joined Cases C-615/20 et C-671/20, *YP and Others*, ECLI:EU:C:2023:562, and Case C-107/23 PPU, *Lin*, ECLI:EU:C:2023:606.

<sup>952</sup> Case 106/77, *Simmenthal*, ECLI:EU:C:1978:49.

<sup>953</sup> European Court of Human Rights, *Case of Xero Flor w Polsce sp. z o.o. v. Poland*, (Application No 4907/18).

<sup>954</sup> Case C-448/23, *Commission v Poland*, (pending, see notice in OJ C 304, 28.8.2023, p. 17).

Other experiences show that European and national judges can find solutions to difficult problems through dialogue and mutual efforts. In the *Taricco* saga, after delivering a first judgment<sup>955</sup> that could put into question the principle of *nulla poena sine lege* enshrined in the Italian Constitution and applicable to limitation periods, the Court of Justice took into account the objections that the Italian Constitutional Court had formulated in a further reference<sup>956</sup>. It concluded that national courts were not required to disapply limitation periods if that disapplication entails a breach of the principle that offences and penalties must be defined by law because of the lack of precision of the applicable law or because of the retroactive application of legislation imposing conditions of criminal liability stricter than those in force at the time the infringement was committed. Further dialogue and mutual understanding between the two courts has prevented a major conflict.

In *La Quadrature du Net*, drawing the consequences of a ruling of the Court of Justice on limits to the retention of personal data imposed by EU legislation and by the Charter of Fundamental Rights,<sup>957</sup> the French *Conseil d'Etat* rejected the surprising suggestion made by the French government that it should disregard that ruling, by stating that “contrary to the argument made by the French Prime Minister, it is not the responsibility of the administrative tribunals and courts to ensure that law derived from the European Union or the Court of Justice itself complies with the distribution of powers between the European Union and the Member States. They cannot therefore exercise control over the compliance of the decisions of the Court of Justice with EU law and in particular, deprive such decisions of their inherent binding force [...] on the grounds that the Court has exceeded its authority by conferring scope on a principle or act of EU law that exceeds the scope provided for in the treaties”. Instead, in its judgment the *Conseil d'État* used the residual margin left to Member States in the matter of data retention to safeguard national security<sup>958</sup>, mentioning that “it is the responsibility of the administrative tribunals and courts, if necessary, to take from the interpretation that the Court of Justice of the European Union has applied to the obligations derived from EU law the reading that complies most closely with [the] requirements [of the French Constitution], insofar as the wording of the Court’s judgments allow it”.

## 1.4 No need for new procedures and bodies

Following the *Weiss* judgment of the German Constitutional Court, very distinguished commentators<sup>959</sup> have suggested that, in the future, cases concerning “the delineation of the jurisdictional line between the Member States and the EU” should be judged by a new appeal jurisdiction, established to review the judgments of the Court of Justice. That court would be composed by an equal number of judges of the Court of Justice

<sup>955</sup> Case C-105/14, *Taricco and Others*, ECLI:EU:C:2015:555.

<sup>956</sup> See Case C-42/17, *M.B and M.A.S.*, ECLI:EU:C:2017:936.

<sup>957</sup> Joined Cases C-511/18, C-512/18 and C-520/18, *La Quadrature du net and Others*, ECLI:EU:C:2020:791.

<sup>958</sup> Conseil d'État, Assemblée No 393099, ECLI:FR:CEASS:2021:393099.20210421.

<sup>959</sup> Sarmiento, D. and Weiler, J.H.H. (2020), “The *EU* Judiciary After *Weiss*: Proposing A New Mixed Chamber of the Court of Justice”, *VerfBlog*, available at <https://verfassungsblog.de/the-eu-judiciary-after-weiss/>.

and of constitutional or supreme courts of the Member States, it would be presided by the President of the Court of Justice or by another judge of that Court who has not participated in the decision under appeal and – oddly – it could only confirm the judgment of the Court of Justice by a qualified majority. My view is that such a suggestion should be rejected. It is premised on the surprising assumption that the boundaries between the EU and national legal orders depend on the composition of the organ called upon to decide, and on voting rules within that organ, rather than on the rules to be applied. I beg to differ: the rules determine the outcome, and this precisely explains the occasional divergences between the (constitutional) courts of the Member States, which apply their respective national rules, and the Court of Justice, which applies EU law. However, I believe that “jurisdictional line” can only be delineated by applying EU law, unless we wish to end up with 27 different versions of the EU legal order as designed on the basis of the constitutional system of each Member States concerned. If so, there is a jurisdiction that was precisely established to interpret and apply EU law, that is perfectly equipped to do so and whose members are appointed by common accord of the governments of the Member States, *de facto* only if the candidates receive a favourable opinion on their suitability by a panel composed, *inter alia*, of members of the national supreme courts.<sup>960</sup> Arguing that EU law should be interpreted by a different court in the most delicate cases would be tantamount to appoint a legal guardian for the Court of Justice, to create a new brand of EU law and to put an end to the autonomy of the EU legal order.

More fundamentally, I am not persuaded that we have witnessed widespread “constitutional contestation”, nor that its tenants have been very convincing or successful so far. In my view, the public debate on the episodes we have discussed, and in particular on the German, Romanian and Polish cases, rather shows extensive support for the CJEU and for its handling of preliminary references. I would draw the consequence that there is no need for new, *ad hoc* procedures and bodies to prevent and resolve constitutional clashes – leaving aside the difficulties to define their respective scope and competences. It would be particularly wrong to even consider such reforms as a reply to ill-conceived attacks like *Weiss* or to the attitude of courts that have become an instrument in the political fight to undermine the rule of law in Europe. What is needed is a strong commitment from all sides to a genuine and respectful judicial dialogue which, as we have seen, has been far more productive.

## 2 Future developments: the transfer of competences to the General Court

Coming to current and future developments, I would like to briefly flag an interesting phenomenon that is already before our eyes. According to Article 23 of the Statute of the CJEU, only the parties to the national case, the Member States, the European Commission and the institution, body, office or agency which adopted the relevant act are entitled to submit written observations to the Court. No provision is made for *amicus curiae* briefs. Indeed, official submissions by third parties, with the need for translation and notification, would probably cause significant delays in a procedure,

---

<sup>960</sup> I am referring, of course, to the panel established by Article 255 TFEU.

that, being an incident in the national case, must remain reasonably swift. However, since 2020 the Court of Justice has published the orders for reference in their original language version, together with a French translation and a meaningful summary in all other official languages, as soon as they become available. Thanks to this practice, we are witnessing an increasing trend to publish comments on pending references. At least for academia, but also for interested parties, such informal participation in the procedure through blogs and online articles seems to represent a practical solution to express views and a remedy to the impossibility to lodge *amicus curiae* briefs.

But of course, the main item I should discuss in this context is the Court's request to transfer preliminary references in certain areas to the General Court. While in the past the Court had resisted this idea, it has now embraced it to ensure that this precious instrument of judicial cooperation remains viable and operational. The Court of Justice has now reached the limits of the workload it can reasonably handle with 27 judges, while the 54 judges of the General Court can deal with additional cases. Therefore, on 30 November 2022, it transmitted to the European Parliament and to the Council a request under Article 281 TFEU for an amendment of Protocol No 3 on the Statute of the CJEU.<sup>961</sup>

The legislative procedure on the request of the Court is ongoing. The European Commission delivered a favourable opinion on the request by the Court of Justice on 10 March 2023.<sup>962</sup> The Council adopted its general approach in the meeting of 8 and 9 June 2023.<sup>963</sup> The JURI Committee of the European Parliament approved its report on 27 September 2023.<sup>964</sup> Quadrilogues are now taking place, and there is hope for a swift political agreement.

Once the amendment of Protocol No 3 on the Statute of the CJEU is adopted, the Court of Justice and the General Court will seek the approval of the Council for the amendment of their respective Rules of Procedure. For the Court of Justice, it will only be necessary to establish detailed rules for the functioning of the one-stop shop and of the review procedure. The General Court, in agreement with the Court of Justice, will have to insert a number of new organisational rules and a whole new title with the procedural rules to be applied to references for a preliminary ruling. The plan is to adopt the new rules before summer 2024, so that the one-stop shop can start allocating references between the two courts in autumn 2024.

Only references that come exclusively within certain specific areas will be transferred to the General Court. These areas have been selected on the basis of the following

---

<sup>961</sup> See Council of the European Union, "Note on the Amendment to Protocol No 3 on the Statute of the Court of Justice of the European Union" (ST 15936, 12 December 2022).

<sup>962</sup> European Commission, "Opinion on the draft amendment to Protocol No 3 on the Statute of the Court of Justice of the European Union, presented by the Court of Justice on 30 November 2022" (COM(2023) 135 final, 10 March 2023).

<sup>963</sup> Council of the European Union, "I/A Item Note on the Amendment of Protocol No 3 on the Statute of the Court of Justice of the European Union - General approach" (ST 9742/23, 26 May 2023) and Council of the European Union, "I/A Item Note on the Amendment of Protocol No 3 on the Statute of the Court of Justice of the European Union - General approach" (ST 9742/23 COR 1, 13 June 2023). See also Council of the European Union, "List of 'A' items" (9919/23 PTS A 41, 7 June 2023), and Council of the European Union, "List of adopted 'A' items" (CM 3345/23 PTS A, 9 June 2023).

<sup>964</sup> European Parliament, "Report on the draft regulation of the European Parliament and of the Council amending Protocol No 3 on the Statute of the Court of Justice of the European Union" (07307/2022 – C9-0405/2022 – 2022/0906(COD), 27 September 2023).

criteria: (i) they are clearly identifiable and sufficiently separable from other areas, (ii) they raise few issues of principle and have seen the development of a substantial body of case-law of the Court of Justice, and (iii) taken together, they represent a sufficiently high share of the references to have a real impact on the Court's workload. The Court's request lists the following six areas: (i) the common system of value added tax, (ii) excise duties, (iii) the Customs Code and (iv) the tariff classification of goods under the Combined Nomenclature, (v) compensation and assistance to passengers, and (vi) the scheme for greenhouse gas emission allowance trading. Taken together, the cases transferred to the General Court should account for roughly 20 % of all requests for a preliminary ruling. It is a sizeable share and the topics are far from insignificant, but it is also clear that the most controversial areas will remain within the province of the Court of Justice. Of course, depending on the outcome of this initial experience, further adjustments are possible.

I will just mention the most salient points of the mechanism that should result from the amendment of the Statute of the Court and the consequential adaptations of the Rules of Procedure of both Courts. The objective is to ensure uniform interpretation and application of EU law, irrespective of which court is called upon to rule on the request for a preliminary ruling. First, there will be a 'one-stop shop' (*guichet unique*), which will allow the Court of Justice to decide, in accordance with objective criteria, which court should deal with each incoming case. Second, the General Court will have the possibility to refer to the Court of Justice a case that "requires a decision of principle likely to affect the unity or consistency of Union law". Third, the Court of Justice may decide to review the decision of the General Court "where there is a serious risk of the unity or consistency of Union law being affected". Fourth, within the General Court references for a preliminary ruling will be assigned to chambers designated for that purpose, and initially to chambers composed of five judges, rather than three as for direct actions. Fifth, important requests for a preliminary may be assigned to an "intermediate chamber", having an intermediate size between the chambers of five judges and the Grand Chamber of 15 judges (the General Court envisages nine judges). Sixth, an Advocate General will be designated in each preliminary ruling case before the General Court; at this stage, it is envisaged that the Advocates General will be elected among the judges for three years and, during that period, will not deal with preliminary references as a judge. All these mechanisms should allow the General Court to reply to preliminary references expeditiously and to deliver rulings of the same quality as the Court of Justice. It may even be anticipated that the judges of the General Court sitting in those cases will quickly become experts in the areas covered by the transfer and will be able to devote more care and attention to preliminary references in these areas than the judges of the Court of Justice can do today.

The transfer of the competences to deliver preliminary rulings in certain areas from the Court of Justice to the General Court, more than 20 years after the entry into force of the Treaty of Nice which first provided for this possibility, will allow the former to concentrate its attention on cases of a greater importance, often with a constitutional dimension, and in that context to enhance the dialogue with national courts; at the same time, it will enable the latter to become a court with general jurisdiction, and not only the administrative court of the EU. This reform will not fundamentally change the nature of the preliminary ruling procedure, but it will show that this instrument has now

become so familiar and well-established that the Court of Justice no longer feels the need to keep it under full control and can entrust its operation to the other court of the EU, subject to certain safeguards for exceptional cases. Of course, national courts will have to accept this change, but they should be ready to cooperate with the General Court as they have done with the Court of Justice for over 60 years. Hopefully, they should soon realise that the quality of the case-law will not decrease and that the reform will allow the two European Courts, together, to continue dealing with preliminary references in a reasonable time. If that is so, the new allocation of cases, and most likely further transfers at a later stage, will ensure that this mechanism remains as successful in the future as it has been until now.



# Effective judicial review in the banking union

Lucia Serena Rossi\*

## 1 The judicial protection in the banking union

Ten years have passed since the establishment of a banking union, founded on the two pillars of the Single Supervisory Mechanism (SSM) and the Single Resolution Mechanism (SRM).<sup>965</sup>

These pillars provide for the intervention of several administrative and judicial authorities, operating at European Union (EU) and at the national level.<sup>966</sup> However, the banking union is based on the fundamental principle that the supervisory and resolution mechanisms must be, as their names suggest, single.<sup>967</sup>

EU and national authorities (NAs) must therefore cooperate in the exercise of their respective tasks and powers.<sup>968</sup> In the recent judgment *Versobank v ECB*,<sup>969</sup> while stressing that the European Central Bank (ECB) has exclusive competence to withdraw authorisation for all credit institutions, irrespective of their size, the Court of Justice (ECJ) explained how the cooperation between the ECB and the National Competent Authorities works in the frame of the SSM regulation. Such cooperation entails, on the one hand, an obligation for the ECB to consult the NAs before withdrawing the authorisation to a non-significant bank on its own initiative, and, on the other hand, the possibility for those authorities to propose such a withdrawal.

EU and NAs must also follow common rules (the so-called single rulebook) and respect common principles, such as the principles of loyal cooperation,<sup>970</sup> non-

---

\* Judge at the ECJ. All opinions hereby expressed are personal and do not bind the institution in any way.

<sup>965</sup> Council Regulation (EU) No 1024/2013 of 15 October 2013 conferring specific tasks on the European Central Bank concerning policies relating to the prudential supervision of credit institutions (OJ L 287, 29.10.2013, p. 63) (SSM Regulation) and Regulation (EU) No 806/2014 of the European Parliament and of the Council of 15 July 2014 establishing uniform rules and a uniform procedure for the resolution of credit institutions and certain investment firms in the framework of a Single Resolution Mechanism and a Single Resolution Fund and amending Regulation (EU) No 1093/2010 (OJ L 225, 30.7.2014, p. 1) (SRM Regulation). A third pillar that should complete the banking union, the European Deposit Insurance Scheme (EDIS), has not yet been established (see, <https://www.consilium.europa.eu/en/policies/banking-union/#pillars>).

<sup>966</sup> See e.g., recitals 13, 15, 28, 60, 60, 67, and 71 and Articles 4, 6 and 24, of the SSM Regulation.

<sup>967</sup> See, to this effect, Article 6(1) of the SSM Regulation: "The ECB shall carry out its tasks within a single supervisory mechanism composed of the ECB and national competent authorities. The ECB shall be responsible for the effective and consistent functioning of the SSM".

<sup>968</sup> See recitals 29 and 47 and, above all, Article 6(2) of the SSM Regulation ("Both the ECB and national competent authorities shall be subject to a duty of cooperation in good faith, and an obligation to exchange information").

<sup>969</sup> Judgment of 7 September 2023, *Versobank v ECB*, C-803/21 P, ECLI:EU:C:2023:630, paras. 139-141.

<sup>970</sup> See e.g., Judgment of 19 December 2018, *Berlusconi and Fininvest*, C-219/17, ECLI:EU:C:2018:102, para. 47.

discrimination – notably between depositors and shareholders of significant and non-significant banks<sup>971</sup> – and effective judicial protection.

In particular, the principle of effective judicial protection – in its dual dimension of fundamental right, granted by Article 47 of the Charter of Fundamental Rights of the European Union (Charter), and of general principle of EU law, stemming from both the constitutional traditions common to the Member States and from Article 6 of the European Convention on Human Rights (ECHR) – plays an essential role in the development of the ECJ case-law on the banking union.

As the *Trasta* judgment shows,<sup>972</sup> this principle applies not only to EU institutions and bodies when they exercise their supervisory and resolution powers, but also to national competent authorities when they act in this area and are implementing EU law within the meaning of Article 51(1) of the Charter.

The effective judicial review provided by the Court of Justice of the European Union (CJEU) in the banking union field is guaranteed not only by means of direct actions (and, notably, action for annulment) brought before the General Court (GC), but also through preliminary references on interpretation and on validity brought before the ECJ. This contribution will be therefore focused on the case-law on the banking union rendered by both the jurisdictions of the CJEU, that is, the ECJ on preliminary rulings and appeals, and the GC on direct actions.

Even if the case-law of the ECJ rendered on preliminary rulings mostly concerns requests of interpretation, this contribution stresses the importance of the preliminary rulings of validity for judicial review in the banking union. As the judgment in *Fédération bancaire française* (FBF)<sup>973</sup> shows, individuals can bring to the Court, through preliminary ruling filled in by national judges, also cases concerning non-binding acts that are not of direct concern to them. In this case, the Court held, in essence, that, despite the fact that European Banking Authority (EBA) guidelines do not produce binding legal effects and, therefore, cannot be subject to an action for annulment under Article 263 TFEU, their validity can be nonetheless be assessed under Article 267 TFEU.<sup>974</sup>

This judgment is particularly important in that it allows the ECJ to extend its jurisdiction to acts adopted by EU agencies (EBA and Single Resolution Board (SRB)), which, in most cases, are non-binding acts, and fall therefore outside the scope of Article 263 TFEU. However, by complementing and clarifying the single rulebook applicable to all

---

<sup>971</sup> The *Novo Banco* case (C-498/22 to C-500/22), currently pending before the ECJ, offers a concrete example of another kind of discrimination, based on residence. In this case, *inter alia*, some Portuguese depositors and shareholders argue that they were not able to appeal a decision adopted by the NA in the proper delay, because of an incorrect fulfillment of the publication requirements. In fact, the NA published the decisions in Spain, where the seat of the parent-bank is located, but not in Portugal, where a branch of the latter is located. The Court will therefore be called upon to assess whether the chosen form complies with the principle of non-discrimination between depositors and shareholders residing in different countries. In particular, shareholders and depositors (backed by the referring court) rely on Articles 17, 21, 38 and 47 of the Charter. The case shows that the Charter can increasingly become a benchmark for individual rights also in banking matters.

<sup>972</sup> Judgment of 5 November 2019, *ECB and Others v Trasta Komerckbanka and Others*, C-663/17 P, C-665/17 P and C-669/17 P, ECLI:EU:C:2019:923, para. 59.

<sup>973</sup> Judgment of 15 July 2021, *FBF*, C-911/19, ECLI:EU:C:2021:599.

<sup>974</sup> *ibid.*, paras. 39 to 50 and paras. 52 to 55, respectively.

credit institutions, non-binding acts adopted by EBA are essential to ensure the unity and effectiveness of banking supervision and resolution, and, at the same time, the non-discrimination between shareholders and depositors.

The possibility for national and legal persons to challenge such acts – even when they are not of direct and individual concern to those persons – and the competence of the CJEU to examine the validity of such acts is therefore essential to ensure an effective legal protection in the banking union field. The preliminary ruling procedure thus plays a fundamental role as “closing rule” of the system of EU judicial remedies in banking union, as the present contribution will show.

A distinctive feature of the banking union procedures is their complexity. Complex procedures are inherent to the banking union, and may take two different forms. On the one hand, when both European institutions or agencies and NAs are involved in the adoption of an EU legal act (vertical procedures). On the other hand, when various European authorities participate in the procedure leading to the adoption of an EU legal act (horizontal procedures).

This contribution will focus on various issues concerning the judicial review of vertical (section 2) and horizontal (section 3) complex procedures, and then on the scope and intensity of judicial review by EU Courts over the discretionary powers of the banking Union institutions (section 4). Finally, it will be briefly considered whether the envisaged reform of the EU judiciary could have an impact in the banking union field (section 5).

## 2 Judicial review of complex vertical procedures in banking union

The judicial review of complex “vertical” procedures, that is, the procedures which involve EU and NAs, raises two essential issues concerning: (i) which acts are subject to judicial review (i.e., the scope of jurisdiction of EU Courts) and, by consequence, before which court such review is to be exercised (i.e. the distribution of jurisdiction among EU and national judges), and (ii) what are the remedies that can be used in the context of such judicial review. These issues, all preliminary to the judicial review, are intrinsically linked to the effectiveness of this review and to the judicial protection under Article 47 of the Charter.

### 2.1 The scope of jurisdiction of EU Courts and the distribution among EU and national judges

The preparatory or definitive nature of the national act adopted in the context of the complex procedure determines not only the ability to review its legality, but also the

judge (EU or national) competent to do so. Both these issues were addressed by the ECJ in the *Berlusconi* and *Fininvest*<sup>975</sup> ruling.

Building upon its previous case-law, the Court clarified that, in the context of complex procedures involving EU and NAs, the fundamental criterion is whether the decision-making power of the EU authority is exclusive. This is measured based on the discretionary power of the EU authority adopting the final EU act with respect to the national preparatory act.

Where the EU authority exercises, alone, the final decision-making power without being bound by the preparatory acts or the proposals of the NAs, and the national act is therefore merely preparatory, then the CJEU has exclusive jurisdiction.

Hence, the CJEU is competent not only to review the legality of the final EU act, but also to examine any defects vitiating the preparatory acts or the proposals of the NAs that would be such as to affect the validity of that final decision. Correspondingly, the national courts are deprived of any jurisdiction, with respect not only to the final act (*Foto-frost*),<sup>976</sup> but also to the national preparatory acts.<sup>977</sup>

A single judicial review is necessary to guarantee the unity and exclusivity of judicial control, symmetrically to the unity and exclusivity of the decision-making power of the EU authority at stake:

“48. Where the EU legislature opts for an administrative procedure under which the national authorities adopt acts that are preparatory to a final decision of an EU institution which produces legal effects and is capable of adversely affecting a person, it seeks to establish between the EU institution and the national authorities a specific cooperation mechanism which is based on the exclusive decision-making power of the EU institution.

49. In order for such a decision-making process to be effective, there must necessarily be a single judicial review, which is conducted, by the EU Courts alone, only once the decision of the EU institution bringing the administrative procedure to an end has been adopted, a decision which is, alone, capable of producing binding legal effects such as to affect the applicant’s interests by bringing about a distinct change in his legal position.

50. If national remedies against preparatory acts or proposals of Member State authorities in this type of procedure were to exist [...], the risk of divergent assessments in one and the same procedure would not be ruled out and, therefore,

---

<sup>975</sup> Judgment of 19 December 2018, *Berlusconi and Fininvest*, C-219/17, ECLI:EU:C:2018:1023.

<sup>976</sup> Judgment of 22 October 1987, *Foto-Frost*, 314/85, ECLI:EU:C:1987:452, para. 17.

<sup>977</sup> Judgment of 19 December 2018, *Berlusconi and Fininvest*, C-219/17, ECLI:EU:C:2018:1023, paras. 43, 44 and 47, respectively. On the contrary, as the Court had already clarified in the judgment of 3 December 1992, *Oleificio Borelli v Commission*, C-97/91, ECLI:EU:C:1992:491, paras. 9 to 13, where (i) the complex procedure provides for a division of powers between national and European authorities, and (ii) the act adopted by the national authority is a necessary stage of a procedure for adopting an EU act in which the EU institutions have only a limited or no discretion, so that the national act is binding on the EU institution – that is, when the national act is preliminary and distinct from the final act, not merely preparatory to it – then it is up to the national judges to exercise judicial review over the national preliminary act, on the same terms on which they review any definitive measure adopted by that national authority; see, to this effect, Judgment of 19 December 2018, *Berlusconi and Fininvest*, C-219/17, cit., paras. 46-47.

the Court's exclusive jurisdiction to rule on the legality of that final decision could be compromised [...]."

Insofar as the complex vertical procedures established in the framework of the SSM are concerned, the ECJ then held that NAs acts concerning significant banks are merely preparatory to ECB's decisions. The ECB is not bound by the proposals of NAs, and has alone the competence to exercise the powers conferred by the SSM Regulation.<sup>978</sup>

The Court therefore ruled that the ECJ has exclusive jurisdiction over ECB's act, which extends to determining whether the preparatory national acts are vitiated by defects, such as to affect the validity of the ECB's decision, and that national courts are precluded to do so, including when national decisions allegedly disregard national judicial decisions:

"57. Consequently, it must be held that the EU Courts alone have jurisdiction to determine, as an incidental matter, whether the legality of the ECB's decision [...] is affected by any defects rendering unlawful the acts preparatory to that decision that were adopted by the Bank of Italy. That jurisdiction excludes any jurisdiction of national courts in respect of those acts [...]

58. [...] the ECB's exclusive competence to decide [...] and the corresponding exclusive jurisdiction of the EU Courts to review the validity of such a decision and, as an incidental matter, to determine whether the preparatory national acts are vitiated by defects such as to affect the validity of the ECB's decision, preclude a national court from being able to hear an action [...].

59. [...] it is immaterial in that regard that a specific action for a declaration of invalidity on the ground of alleged disregard of the force of *res judicata* attaching to a national judicial decision has been brought before a national court."

Shortly afterwards, in *Iccrea Banca*,<sup>979</sup> the ECJ transposed the conclusions reached for the SSM to the other pillar of the banking union, i.e. the SRM. Recalling almost verbatim the reasoning developed in *Berlusconi* and *Fininvest*, the ECJ affirmed the exclusive jurisdiction of the CJEU over SRB acts and national preparatory acts:

"48. Consequently, the EU Courts alone have jurisdiction to determine, when reviewing the legality of a decision of the Board setting the amount of the individual *ex ante* contribution to the SRF of an institution, whether an act adopted by a national resolution authority that is preparatory of such a decision is vitiated by defects capable of affecting that decision of the Board, and no national court can review that national act."

---

<sup>978</sup> Judgment of 19 December 2018, *Berlusconi and Fininvest*, C-219/17, ECLI:EU:C:2018:1023, paras. 53-55.

<sup>979</sup> Judgment of 3 December 2019, *Iccrea Banca*, C-414/18, ECLI:EU:C:2019:1036, paras. 37-48.

## 2.2 The available remedies

Finally, given that the ECJ has exclusive jurisdiction over final and preliminary acts adopted in the framework of the banking union but also, incidentally, over preparatory acts, and that these acts may also include national acts, what kind of remedies should the ECJ use for this purpose? Besides that, when the ECJ is confronted with national law, whether it is a question of incidentally reviewing national preparatory acts or when it is a question of controlling the way in which the ECB has applied national law transposing EU directives,<sup>980</sup> what is the relevance of the preliminary ruling procedure “toolbox” (i.e. consistent interpretation and setting aside of conflicting national law)?

The answer will probably come from the appeal in the *Corneli v ECB* case,<sup>981</sup> which is currently pending before the ECJ. This case concerns a decision of the ECB to place a bank under temporary administration, based on a provision of national law. The applicant maintains that the GC erred in law in applying that national provision to a situation that did not expressly fall within its scope of application.

When checking the legality of the contested ECB’s decision, the GC treated the ECB as a national judge. The GC considered that, when the ECB’s acts as the competent supervisory authority and is confronted with a situation governed by a directive, it is obliged to apply (only) national legislation transposing that directive. In so doing, the ECB is – much like a national court – under an obligation to interpret national law in conformity with EU law. However, this obligation cannot serve as the basis for an interpretation of national law *contra legem*.

According to the GC, when adopting the contested decision, the ECB went beyond a consistent interpretation of national provisions in the light of Directive 2014/59 and against the letter of the applicable national provision. The GC concluded that the ECB erred in law and annulled the decision. Moreover, mentioning the horizontal effect that the directive would have had, the GC implicitly excluded that the ECB could set aside the national law.

In the appeal, the ECJ will therefore be called upon to decide not only whether the ECB can be assimilated to a national authority (be it judicial or administrative) when exercising supervisory powers on the basis of national law, but also how the ECB must apply national law in this context. In particular, the ECJ must verify, on the one hand, whether the national law “incorporated” by EU law sets the same limits to the obligation of consistent interpretation and, on the other hand, whether the ECB is subject to the same limits as the NAs with respect to the setting aside of this “incorporated” national law, when it conflicts with EU law.

In my personal view, when applying national law transposing EU law, the ECB should not be compared to a jurisdiction, but rather to an administrative authority. Thus, it should follow the principles that the ECJ has established for national administrative

---

<sup>980</sup> Article 4(3) of the SSM Regulation provides in particular that, to carry out its supervisory tasks, the ECB should apply “all relevant EU law”. When it consists of Directives, the ECB should also apply the national transposing legislation. Similarly, when Regulations grant options for the Member States, the ECB should apply the national legislation exercising such options.

<sup>981</sup> Case C-777/22 P; the appeal has been brought against the Judgment of 12 October 2022, *Corneli v ECB*, T-502/19, ECLI:EU:T:2022:627.

authorities since *Costanzo*.<sup>982</sup> The ECB should therefore not only interpret the applicable national law as far as possible in conformity with EU law, but also set aside this national law when this proves impossible.

In this latter respect, it remains however to be seen whether the obligation to set aside conflicting national law is conditional upon the direct effect of the EU law provision at stake. To this regard, the possible impact of the “incorporation” of national law by EU law on the applicability of the *Popławski II* case-law<sup>983</sup> should notably be assessed. The Court will have to decide whether, in this particular context, the principle of primacy and its corollaries, including the obligation to set aside conflicting national law, could prevail over that of direct effect.

### 3 Judicial review of complex “horizontal” procedures

Obviously, complex horizontal procedures involving EU authorities only do not pose the same problems of vertical distribution of jurisdiction between EU and national courts that complex vertical procedures raise. All acts adopted in the context of complex horizontal procedures are in fact subject to the exclusive jurisdiction of the CJEU. Nonetheless, these latter procedures raise the issue of the scope of this jurisdiction, and, more particularly, of the possible judicial review of preparatory acts.

Since *IBM*,<sup>984</sup> the Court clarified that, in principle, in the context of complex horizontal procedures, preparatory acts with respect to the final decision cannot be the subject of autonomous judicial review. Any defects vitiating them may therefore only be relied upon in action against the final act. On the contrary, preliminary acts to a final decision that definitely lay down the position of the institution and are adopted by means of a distinct procedure may be subject to autonomous review.

Against this background, two separate but intertwined issues arise in the context of SRM.

The first issue is whether, in the context of the resolution procedure, the authority of the institution (ECB) adopting an act that is preparatory to the final decisions adopted by another institution or agency (SRB) may render this preparatory act amenable to autonomous judicial review as a “binding act”, in that the SRB will likely endorse the ECB’s assessment.

In *ABLV*<sup>985</sup> (C-551/19 P and C-552/19 P), the ECJ dealt with the question whether ECB’s acts directed to a final decision of the SRB can be challenged under Article 263 TFEU. In that case, an assessment of the ECB (of whether an entity is failing or is likely to fail) led to a decision (to adopt a resolution scheme) taken by the SRB. The applicants claimed that the ECB’s assessment, publicly announced and

---

<sup>982</sup> Judgment of 22 June 1989, *Costanzo*, 103/88, ECLI:EU:C:1989:256.

<sup>983</sup> Judgment of 24 June 2019, *Popławski*, C-573/17, ECLI:EU:C:2019:530; see also judgment of 18 January 2022, *Thelen Technopark Berlin*, C-261/20, ECLI:EU:C:2022:33.

<sup>984</sup> Judgment of 11 November 1981, *IBM v Commission*, 60/81, ECLI:EU:C:1981:264, paras 10-12.

<sup>985</sup> Judgment of 6 May 2021, *ABLV Bank and Others v ECB*, C-551/19 P and C-552/19 P, ECLI:EU:C:2021:369.

communicated to the credit institutions, affected its legal situation in a direct way, and filed an action for its annulment.

Following the rationale of *IBM*, the GC dismissed the action,<sup>986</sup> and the ECJ upheld the GC's decision. The ECJ held, in essence, that, in order to determine whether an act is preparatory or definitive, it is necessary to look at the "actual substance" and not at the authority from which the act originates. In the complex administrative procedure of banking resolution, the binding legal effect arose not from the ECB's assessment but from the adoption (by the SRB) and the subsequent entry into force (after the scheme is endorsed by the Commission/Council) of a resolution scheme. Even if, in most cases, the SRB will probably endorse the ECB's assessment, this does not put the SRB in a position where its powers in respect of that assessment are circumscribed.<sup>987</sup>

Therefore, the likely "conforming" effect resulting from the *auctoritas* of the ECB should not be taken into consideration. Indeed, what matters is only the *potestas* at stake, which exclusively resides in the SRB's final decision:

"69. It is true that, in fact, the ECB's expertise and its knowledge of supervisory information relating to the entity concerned are such that the SRB will probably in most cases endorse the ECB's assessment. However, [...] while there is 'no objection to the assumption that the ECB's assessment may carry *auctoritas* within the classical sense of that term, and that the SRB could not refrain from taking it into account or reject its content uncritically', 'this does not mean ... that it is also vested with the *potestas* inherent in legal decisions that are imposed in relations between institutions in the case where one of them may not depart from the substance of what the other has agreed or decided to do'".

A second issue arises as to whether the preparatory or rather preliminary nature of an act adopted in the context of the resolution procedure must be determined on the basis of the procedural constraints established by the SRM Regulation for its entry into force.

The complex procedure of banking resolution provides that the resolution scheme, adopted by the SRB in the form of a decision, must be endorsed by the Commission or the Council in order to enter into force.<sup>988</sup> Is this procedural constraint such as to make the SRB decision a preparatory act? This is the question at issue in the case *Commission v SRB*.<sup>989</sup>

According to the GC, unlike the ECB's assessment at issue in the *ABLV* judgment, which is of a preparatory nature, the resolution scheme adopted by the SRB in the form of a decision is an act capable of being subject to an autonomous action of annulment. The test is the same used in *ABLV* (substance of the act), but here the

---

<sup>986</sup> Order of 6 May 2019, *ABLV Bank v ECB*, T-281/18, ECLI:EU:T:2019:296. The GC held that, since the SRB has the exclusive power under Article 18(1) of the SRM Regulation, and since the ECB's assessment does not bind the SRB, the ECB's assessment is a preparatory act and therefore cannot be subject to Article 263 TFEU. Besides that, the GC held that the requirements stemming from Article 47 of the Charter are fulfilled by the possibility to bring an action for annulment of the final SRB's decision.

<sup>987</sup> See judgment of 6 May 2021, *ABLV Bank and Others v ECB*, C-551/19 P and C-552/19 P, ECLI:EU:C:2021:369, paras. 40-41, 66 and 67-69.

<sup>988</sup> See Article 18 (paras. 1, 6 and 7) of Regulation No 806/2014.

<sup>989</sup> C-551/22 P, currently pending before the ECJ.



result is different. According to the GC, the decision of the SRB in fact produces binding legal effects on the national resolution authorities and the final result of the resolution procedure derives from the exercise of a competence of the SRB. Given that the Commission and the Council can only object but not modify the content of the resolution scheme, the fact that its legal effects are conditional upon the approval of the Commission does not mean that it is the SRB decision that enters into force.<sup>990</sup>

In light of the reasoning of the ECJ in *ABLV*, where the *potestas* is formally shared, the GC seems to suggest to go back to the actual *auctoritas* and not to the procedures for its adoption in order to determine its challengeable nature. Considering the importance of the issues at stake, the Court has attributed this case to the Grand Chamber.

## 4 The scope and intensity of judicial review over the discretionary powers of the banking EU institutions

The judicial review of complex procedures is based on the exclusive jurisdiction of the CJEU with respect to the final act that concludes this procedure. In turn, the qualification of a given act as final depends on whether it is adopted in the exercise of an exclusive and discretionary power. Preparatory acts, be they national or European, are excluded as such from review, without prejudice however to the possibility of asserting their defects in the context of an action laid down against the final act. However, if both the preparatory and final acts are the product of a discretionary power, to what extent will the EU Courts be able to review its legality?

It must be recalled that the ECJ has granted a wide margin of discretion to the EU institutions, and notably the Commission, when dealing with complex technical issues, be they economical or scientific.<sup>991</sup> This has translated in a certain judicial deference towards the exercise of this discretionary power, whereby the judicial review is confined to a mere extrinsic control of legality, limited to verifying whether the contested decision “contains a manifest error or constitutes a misuse of power or whether the authority did not clearly exceed the bounds of its discretion.”<sup>992</sup>

To what extent is this settled case-law applicable to the banking union field?

Two main issues may be singled out in this respect, concerning, respectively, (i) the acts adopted by the ECB in the framework of the SSM, and (ii) the decisions taken by the SRB in the framework of the SRM.

On the one hand, insofar as the ECB is concerned (SSM pillar), the question is whether the *IBM* case-law offers a fair balance between the protection of the prerogatives of

---

<sup>990</sup> Judgment of 1 June 2022, *Fundación Tatiana Pérez de Guzmán el Bueno and SFL v SRB*, T-481/17, ECLI:EU:T:2022:311, paras. 120, 122, 124, 132, 136-137, 140, 141, 146, 147 and 149.

<sup>991</sup> See judgment of 16 June 2015, *Gauweiler and Others*, C-62/14, ECLI:EU:C:2015:400, para. 68 and order of 4 September 2014, *Rütgers Germany and Others v ECHA*, C-290/13 P, not published, ECLI:EU:C:2014:2174, para. 25.

<sup>992</sup> See, *inter alia*, judgments of 25 January 1979, *Racke*, 98/78, ECLI:EU:C:1979:14, para. 5 and of 11 December 2018, *Weiss and Others*, C-493/17, ECLI:EU:C:2018:1000, para. 24.

the ECB under the Treaties and the effectiveness of the guarantees offered to individuals by Article 47 of the Charter. It should in fact be recalled that the ECB has a peculiar legal status under Article 282(3) TFEU, in that it benefits from a fully-fledged institutional independence, extending beyond that of the members of its governing bodies. However, the ECB is nonetheless subject under the Treaty to the same standard of judicial control of other EU institutions.

On the other hand, given that the SRM pillar involves an EU agency (SRB), the question arises as to whether the *IBM* principle of the limited control of acts adopted in the exercise of technical discretion also applies to the SRB and, if so, to all degrees of judicial or quasi-judicial control to which the SRB binding acts are subject. In other words, if the intensity of judicial review over these acts is to be the same as for the EU institutions at all procedural stages.

The first issue was addressed by the ECJ in the recent *Crédit Lyonnais v ECB* judgment.<sup>993</sup>

The case arose from an appeal brought by the ECB against a judgment, by which the GC upheld an action for annulment against an ECB's decision.<sup>994</sup> According to the ECB, the GC disregarded the limits on the exercise of its judicial review, by substituting its own assessment for that made by the ECB.

The ECJ set aside the GC judgment and dismissed the action at first instance. To this effect, the ECJ first, reaffirmed the broad discretion of the ECB in the field of banking supervision and the correspondingly limited judicial review that the ECJ must carry out.

"55 As the General Court pointed out, in essence, in paragraph 98 of the judgment under appeal, in so far as the ECB has a broad discretion in deciding whether or not to apply Article 429(14) of Regulation No 575/2013, the judicial review which the Courts of the European Union must carry out of the merits of the grounds of a decision such as the decision at issue must not lead it to substitute its own assessment for that of the ECB, but seeks to ascertain that that decision is not based on materially incorrect facts and that it is not vitiated by a manifest error of assessment or misuse of powers."

Based on its previous case-law, the ECJ then clarified the scope and intensity of this limited judicial review:

"56. In that regard, it is settled case-law that the Courts of the European Union must, inter alia, establish not only whether the evidence relied on is factually accurate, reliable and consistent but also whether that evidence contains all the relevant information which must be taken into account in order to assess a complex situation and whether it is capable of substantiating the conclusions drawn from it."

---

<sup>993</sup> Judgment of 4 May 2023, *ECB v Crédit Lyonnais*, C-389/21 P, ECLI:EU:C:2023:368.

<sup>994</sup> Judgment of 14 April 2021, *Crédit Lyonnais v ECB*, T-504/19, ECLI:EU:T:2021:185.

In this context, the ECJ recalled, by referring, in particular, to its *Weiss* judgment, the importance, for institutions vested with discretionary powers, to respect the procedural and substantive aspects of the duty to state reasons.<sup>995</sup>

Hence, when carrying out the judicial review of an ECB's decision the EU judges must check: (i) the material accuracy, reliability and consistency of the factors taken into account in that decision; (ii) the completeness of these factors, with respect to the set of relevant information which had to be taken into consideration by the ECB in the present case; and (iii) whether assessment made by ECB was manifestly incorrect. To this end, the EU Courts should only verify that the option chosen by the ECB is not manifestly incorrect, that is, it is *prima facie* correct, not whether it is more correct than the other possible decisions which the ECB could have taken on the basis of the (exhaustive and accurate) factors taken into consideration. Once the ECB has complied with its duty to state reasons, the burden of proof therefore falls on the appellant.<sup>996</sup>

Finally, it should also be recalled that, as the *Weiss* judgment shows, this verification of the existence of manifest errors of assessment might fall within the scope of a broader proportionality check to the effect that the contested decision does not go manifestly beyond what is necessary to achieve its objective.<sup>997</sup>

As to the scope and intensity of the review of decisions adopted by the SRB in the field of banking resolution, the situation differs depending on whether the controlled is exercised by the CJEU or by the Board of Appeal (BoA) of the SRB.

As for the CJEU, the answer largely depends on the outcome of the pending appeal in *Commission v SRB*. If the ECJ upholds the GC's ruling, with the effect of confirming the autonomous challengeability of the main decision adopted by the SRB in the framework of the banking resolution (i.e. the decision adopting the resolution scheme), then the question of the extent of the control exercised by the court over this kind of acts will arise. More particularly, the question of whether, and to what extent, the case-law concerning the SSM and the ECB could be extended to the SRM and the SRB would likely arise in future cases.

With regards to the BoA of SRB, it should be recalled that the ECJ has already clarified, in *Aquind*, that, unlike the EU judiciary, the BoAs must conduct a "full review" of the merits of the contested decision, and not limit themselves to the review of manifest errors of assessment.<sup>998</sup> This principle, affirmed by the ECJ in relation to the BoA of another agency (ACER), can be applied by analogy to other BoAs, including the appeal panel of the SRB. However, it should be kept in mind that, contrary to other BoAs, the SRB's BoA has a merely facultative "jurisdiction". Privileged applicants, but

---

<sup>995</sup> *ibid.*, para. 57.

<sup>996</sup> Judgment of 4 May 2023, *ECB v Crédit lyonnais*, C-389/21 P, ECLI:EU:C:2023:368, paras. 70-73.

<sup>997</sup> Judgments of 11 December 2018, *Weiss and Others*, C-493/17, ECLI:EU:C:2018:1000, paras. 78 and 79.

<sup>998</sup> See, to this effect, judgment of 9 March 2023, *ACER v Aquind*, C-46/21 P, ECLI:EU:C:2023:182, paras. 55-73. An appeal brought against a GENCO's ruling concerning a decision taken the BoA of EUIPO (judgment of 7 December 2022, *Neoperl v EUIPO (Representation of a cylindrical sanitary insert)*, T-487/21, ECLI:EU:T:2022:780), which has recently been allowed to proceed by the ECJ, could bring some clarifications on "the other side of the coin" of ECJ *ACER v Aquind* judgment, namely the scope of GENCO's control over the full review exercised by the BoAs.

also natural and legal persons, may in fact decide to bring proceedings against decisions of the SRB directly before the EU Courts.<sup>999</sup>

So far, the overwhelming majority of actions against SRB decisions have indeed been lodged before the GC, but the outcome of the appeal in the *Commission v SRB* case will arguably be decisive also in this respect. If the ECJ considers that the resolution schemes adopted by the SRB cannot be autonomously challenged before the EU Courts, the appellants would have no other way than the internal review before the SRB's BoA. On the one hand, this would guarantee the addressees of these decisions a "full review" of their merits by the BoA. On the other hand, it would however deprive, in principle, the ECJ of the last word, given that the current proposal of the reform of the CJEU Statute provides for the extension of the so-called filtering mechanism to the SRB (see *infra* section 5).

## 5 The (limited) impact of the envisaged reform of the CJEU on the judicial review in banking union

On 30 November 2022, the ECJ presented a draft amendment of Protocol No 3 on the Statute of the ECJ, based on Article 281(2) TFEU.<sup>1000</sup> The proposal has two goals. It aims, on the one hand, at extending the material scope of the so-called filtering mechanism for appeals established in 2019,<sup>1001</sup> and, on the other hand, at conferring jurisdiction to hear and determine questions referred for a preliminary ruling under Article 267 TFEU to the GC in five specific areas.

Despite the expectations, the proposal will have only a limited impact on the judicial review in the field of banking union.

On the one hand, as to the extension of the filtering mechanism for appeals,<sup>1002</sup> it is true that, if the proposal is adopted by the EU legislator, decisions adopted by EBA and SRB will fall within the scope of the filtering mechanism. However, the jurisdiction of their BoAs is facultative, and most decisions adopted by EU banking agencies will most likely continue to be directly challenged before EU courts (without prejudice to the possible effects of the appeal in the *Commission v SRB* case). Moreover, the acts adopted by the SSM's Administrative Board of Review (ABoR) are non-binding and thus excluded from the filter.

On the other hand, as to the devolution of preliminary jurisdiction to the GC, none of the specific areas affected by the proposed transfer of jurisdiction concerns directly or

---

<sup>999</sup> See Article 86(2) of SRM Regulation.

<sup>1000</sup> See [https://curia.europa.eu/jcms/jcms/p1\\_3866197/en/](https://curia.europa.eu/jcms/jcms/p1_3866197/en/).

<sup>1001</sup> The last amendments of the Statute, entered into force on 1 May 2019, introduced a filtering mechanism applicable to appeals brought against decisions of the GC concerning decisions of the independent boards of appeal of four offices and agencies of the Union (Article 58a of the Statute). The filter is based on the principle (Article 58a(3) of the Statute) that an appeal will not be allowed to proceed, wholly or in part, unless it raises an issue that is significant with respect to the unity, consistency, or development of EU law. The practice has shown that very rarely appeals are allowed to proceed.

<sup>1002</sup> The proposal of the ECJ provides for the extension of the filtering mechanism to all the ten agencies that are endowed with decision-making powers and therefore with a BoA. Along with the four agencies that are currently listed in Article 58a(1) of the Statute (EUIPO, CPVO, ECHA and EASA), the proposal lists the BoAs of ACER, SRB, EBA, ESMA, EIOPA, and ERA.

indirectly the banking union. The future transfer to the GC of other “specific areas” within the meaning of Article 256 (3) TFEU, including banking union, certainly cannot be ruled out. However, it should be noted that one of the criteria used by ECJ to identify the areas of preliminary ruling jurisdiction to be transferred to the GC is the existence of a “substantial body of ECJ case-law” in the field concerned.

This suggests that, even if the transfer of jurisdiction to hear references for preliminary rulings to the GC proves to be successful, it is unlikely that such a jurisdiction in the banking union field will be transferred to the GC in the future. Indeed, the ECJ’s case-law in this area is in fact far from being consolidated, and the ECJ will still be called upon to clarify the guiding principles for interpreting EU banking law.

The particular sensitivity of this field of law suggests in any case preserving, for both direct actions and references for preliminary ruling, the full “constitutional” role of the ECJ.





## Part VIII

# Protection of Fundamental Rights in the European Multilevel System



# Protection of Fundamental Rights in the European Multilevel System

Prof. Dr. Stephan Harbarth\*

## 1 Introduction

The European Union (EU) is faced with threats from within and beyond its borders. Russia's war of aggression against Ukraine, which is contrary to international law, is battering the foundations of the peaceful order of Europe and throws our own vulnerability into sharp relief. I could list many more challenges, such as the unresolved issues of climate change and migration, as well as the ongoing rule-of-law problems in individual EU Member States, and the fact that our societies are noticeably drifting apart. Hence, now is certainly a good time to look at some fundamental issues.

In the EU, the gift of a life lived in peace, democracy and freedom under the rule of law is something we largely owe to the process of European integration and the formation of a European community of law, or – to quote the apt, if somewhat ambitious, phrase formulated by the first President of the European Commission, Walter Hallstein – to the “replacement of power by law”. Many persons and institutions have made their contribution to the common European project. One is the institution publishing this book: for the past 25 years, the huge responsibility of looking after one of the key projects of European integration – namely the euro as a common currency for the now 20 members of the euro area – has rested on the shoulders of the European Central Bank (ECB).

It is not just the current challenges, but also historical events that motivated me to participate to this book with a contribution on the protection of fundamental rights. 175 years ago, in 1848, the St. Paul's Church Assembly convened in Frankfurt. In many parts of Europe, it was a time when the spirit of freedom was beginning to assert itself and the dialogue surrounding the notion of liberty was creating bonds that transcended national borders and that united European intellectual culture. Given that German history is not overly blessed with respectable anniversaries of constitutional significance, it is fortunate that just before the Conference we were also able to commemorate the 75th anniversary of the convening of the Parliamentary Council in Bonn on 1 September 1948, which – building on the preparatory work of the Herrenchiessee Convention – drafted the Basic Law in 1949, thereby presenting us Germans with a great gift.

This gift – a response to the atrocities and injustices perpetrated by the Nazi regime – is rooted, first and foremost, in the decision by the drafters of the Basic Law to place

---

\* Transcript of keynote speech given during ECB Legal Conference 2023. President of the German Federal Constitutional Court.

the protection of human and fundamental rights at the very pinnacle of our Constitution.

Another path-defining element in the Basic Law was the decision to allow the Federal Republic of Germany to transfer sovereign powers to supranational organisations in order “to promote world peace as an equal partner in a united Europe”, in particular for the purpose of participating “in the development of the European Union” with a “view to establishing a united Europe”, to quote Article 23 of the Basic Law.

In this contribution, I will briefly outline how the Federal Constitutional Court ensures that the first of these two constitutional mandates – namely the protection of fundamental rights – is also guaranteed when exercising the second one – namely the transfer of sovereign powers to EU institutions.

As you know, fundamental rights in Europe are protected on various levels: from an early stage, the national fundamental rights set down in the constitutions of the Member States were supplemented by the human rights and fundamental freedoms enshrined in the European Convention on Human Rights (ECHR) at the level of the Council of Europe. Further fundamental rights were gradually added at the supranational level of today’s EU, initially as general principles of law developed by the Court of Justice and, since 2009, in the form of the written catalogue that is the Charter of Fundamental Rights of the European Union. This multi-level system also has an institutional aspect: the Federal Constitutional Court and the other domestic constitutional courts, together with the European Court of Human Rights and the Court of Justice of the European Union (CJEU), interact with one another through what is known as the ‘multi-level cooperation of European constitutional courts’.

This is a highly topical subject – perhaps not by the standards that apply in financial markets, but certainly in terms of the speed at which constitutional law normally develops. With two decisions issued on 6 November 2019 relating to the so-called *Right to be forgotten*<sup>1003</sup> and the subsequent decisions *European Arrest Warrant III*<sup>1004</sup> from December 2020 and *Ecotoxicity*<sup>1005</sup> from April 2021, the Federal Constitutional Court realigned its traditional standard of review for dealing with constitutional complaints, thereby also adapting its own role in guaranteeing fundamental rights protection within the multi-level cooperation of European courts. Outside expert circles, these decisions may have been somewhat overshadowed by the media coverage of the Federal Constitutional Court’s *PSP*<sup>1006</sup> decision of May 2020 relating to the asset purchases of the ECB. Nevertheless, I consider them to be no less important for the further development of the European integration process, which is why I would like to address them as well.

---

<sup>1003</sup> BVerfG, Order of the First Senate of 6 November 2019 - 1 BvR 16/13, ECLI:DE:BVerfG:2019:rs20191106.1bvr001613; Order of the First Senate of 6 November 2019 - 1 BvR 276/17, ECLI:DE:BVerfG:2019:rs20191106.1bvr027617.

<sup>1004</sup> BVerfG, Order of the Second Senate of 1 December 2020 - 2 BvR 1845/18, ECLI:DE:BVerfG:2020:rs20201201.2bvr184518.

<sup>1005</sup> BVerfG, Order of the Second Senate of 27 April 2021 - 2 BvR 206/14, ECLI:DE:BVerfG:2021:rs20210427.2bvr020614.

<sup>1006</sup> BVerfG, Judgment of the Second Senate of 5 May 2020 - 2 BvR 859/15, ECLI:DE:BVerfG:2020:rs20200505.2bvr085915.

## 2 *Solange* cases

Tradition dictates that we first take a brief look at two key decisions from the past. With the so-called *Solange I*<sup>1007</sup> decision from 1974, the Federal Constitutional Court held that sovereign powers may only be transferred to what was then the European Communities if adherence to certain structural requirements is ensured, which mainly concerned fundamental rights protection. The central part of the decision was formulated thus: “[a]s long as the integration process of the European Communities has not progressed so far that Community law also contains an operative catalogue of fundamental rights that has been adopted by a parliament and is congruent with the fundamental rights catalogue of the Basic Law, a court of the Federal Republic of Germany [...] is permitted – and required – to refer the matter to the Federal Constitutional Court [...] if the court in question considers [...] the relevant provision of Community law to be inapplicable on the grounds that or to the extent that it conflicts with one of the fundamental rights enshrined in the Basic Law.”<sup>1008</sup> Put differently, as long as Community law does not provide for a level of fundamental rights protection that is comparable to the protection guaranteed by the Basic Law, the Federal Constitutional Court will review Community law against the standard of the fundamental rights of the Basic Law in order to ensure that the level of protection guaranteed to individuals by fundamental rights is not undermined by the transfer of sovereign powers to European institutions.

About 12 years later the Court of Justice had reacted to the challenge presented in the *Solange I* decision and, with reference to the guarantees of the ECHR and the common constitutional traditions of the Member States, had developed an initially unwritten fundamental rights catalogue, which later provided important impetus for the drafting of the Charter of Fundamental Rights of the European Union, which entered into force on 1 December 2009. In response to this development of EU fundamental rights, which – as already mentioned – first became visible in the case-law of the Court of Justice, the Federal Constitutional Court held in the so-called *Solange II*<sup>1009</sup> decision from 1986 that the European Communities now guaranteed effective protection of fundamental rights vis-à-vis the public authority of the Communities in a manner that was essentially equivalent to the protection regarded as indispensable under the Basic Law. ‘As long as’ (*Solange*) this was the case, the Federal Constitutional Court would no longer exercise its jurisdiction over the applicability of derived Community law and thus no longer review such law against the standard of the fundamental rights of the Basic Law.<sup>1010</sup>

The Federal Constitutional Court thus recognises – in what is now established case-law – that EU law takes precedence of application over national law and that a review on the basis of the Basic Law’s fundamental rights is excluded as long as the protection afforded by EU fundamental rights is sufficiently effective. In other words, ‘as long as’ has a conditional meaning in addition to its temporal meaning. The level of protection under the Charter must be equivalent to the fundamental rights standards

---

<sup>1007</sup> BVerfG, Order of the Second Senate of 29 May 1974 - 2 BvL 52/71.

<sup>1008</sup> *ibid.*

<sup>1009</sup> BVerfG, Order of the Second Senate of 22 October 1986 - 2 BvR 197/83.

<sup>1010</sup> *ibid.*

that are regarded as indispensable under the Basic Law and must generally serve to guarantee the essence of German fundamental rights. The Federal Constitutional Court's determination of whether the level of protection is equivalent depends on the specific fundamental right in question and is based on a general assessment of the level of protection in place at EU level.

Put simply, this is about the division of labour: the Federal Constitutional Court reviews acts of German state authority on the basis of the fundamental rights of the Basic Law, while the CJEU ensures adherence to EU fundamental rights in the implementation of EU law.

### 3 Right to be forgotten

This division of labour is illustrated by the two *Right to be forgotten* decisions issued in 2019.<sup>1011</sup> In order to understand these decisions, a distinction must first be made. One of these decisions concerns cases in which EU law affords Member States latitude in the design of legislation, while the other concerns cases in which no such latitude exists. Both decisions addressed questions of fundamental rights protection in view of the realities of internet communication, and specifically the protection against the possibility that anyone could retrieve personal information related to past events via search engines. These cases were thus about the existence and scope of a so-called right to be forgotten, which the Court of Justice had already dealt with, in particular in its *Google Spain and Google* judgment of 2014.<sup>1012</sup> The following sections will not focus on the substantive right to be forgotten, but rather on the Federal Constitutional Court's general statements regarding fundamental rights protection in cases where Member States are implementing EU law.

#### 3.1 First Right to be forgotten

The first *Right to be forgotten* decision concerned the constitutional complaint of a man who was convicted in 1982, among other things for two murders. The news magazine *Der Spiegel* had run several articles about the case. These articles, in which the complainant's last name is used, were freely available from an online archive from 1999 onwards. A Google search for his name listed the articles in question among the top search results. After serving a long prison sentence, the complainant brought a cease-and-desist action against the provider of the online archive, but his action was rejected. The Federal Constitutional Court reversed that decision because it violated the complainant's general right of personality under Article 2 in conjunction with Article 1 of the Basic Law.

The Federal Constitutional Court's decision contains key points regarding the relationship between fundamental rights protection under the Basic Law and

---

<sup>1011</sup> BVerfG, Order of the First Senate of 6 November 2019 - 1 BvR 16/13, ECLI:DE:BVerfG:2019:rs20191106.1bvr001613; Order of the First Senate of 6 November 2019 - 1 BvR 276/17, ECLI:DE:BVerfG:2019:rs20191106.1bvr027617.

<sup>1012</sup> Case C-131/12, *Google Spain and Google*, ECLI:EU:C:2014:317.

fundamental rights protection under EU law. The case raised this question because the area affected was determined by EU law. It revolved around protection against the processing of personal data. As we know, the legal regime for data processing, including processing by private parties, has been harmonised under EU law, originally through the Data Protection Directive and now through its successor, the General Data Protection Regulation. According to the case-law of the CJEU, this area is for the most part fully harmonised, leaving Member States no latitude. However, there is one exception: each Member State is entitled to design the so-called media privilege in its own country. Under EU law, Member States are required to enact their own provisions for journalistic, academic, artistic or literary activities in order to take into account the special nature of these activities. Our case arose in this area, in which Member States enjoy legislative latitude, since the case dealt with a press archive, and therefore concerned data processing for journalistic purposes. The key findings of the Federal Constitutional Court regarding such areas for which Member States have legislative latitude are for the most part in line with the recognised lines of case-law. They can be summarised as follows.

In areas where Member States have latitude in implementing EU law, and which are thus not determined by EU law, the fundamental rights of the Basic Law are applicable and can be invoked by constitutional complaint before the Federal Constitutional Court.<sup>1013</sup> This directly follows from the Basic Law. The same also follows from EU law. Under Article 51(1) first sentence of the Charter of Fundamental Rights of the European Union, the Member States are bound by EU fundamental rights “only when they are implementing Union law”. The Charter of Fundamental Rights does not therefore provide comprehensive fundamental rights protection against each and every sovereign act carried out in the EU. Instead, its limited scope of application serves to acknowledge the diversity of the fundamental rights guarantees of the Member States. This may not be circumvented by an untenably broad interpretation of Article 51(1) first sentence of the Charter. Conversely, the Federal Constitutional Court does not rule out the possibility that domestic implementation measures may be judged to be provisions “implementing Union law” within the meaning of Article 51(1) first sentence of the Charter in cases where EU law affords Member States latitude in the design of such provisions, but also provides for a sufficiently substantial framework for this design, and it is ascertainable that the framework is to be specified in consideration of EU fundamental rights. The EU fundamental rights are then applicable in addition to the fundamental rights guarantees of the Basic Law. In such cases, the Federal Constitutional Court primarily relies on the fundamental rights of the Basic Law as its standard of review. The possibility of such co-existence of national and EU fundamental rights in areas for which Member States retain latitude corresponds to the European Treaties, which guarantee the diversity of fundamental rights protection, and to the case-law of the Court of Justice. In the *Åkerberg Fransson*<sup>1014</sup> case and again in the – German – referral in the *Pelham*<sup>1015</sup> case, the Court of Justice emphasised that in situations where the action of the Member States

---

<sup>1013</sup> BVerfG, Order of the First Senate of 6 November 2019 - 1 BvR 16/13, ECLI:DE:BVerfG:2019:rs20191106.1bvr001613, para. 42.

<sup>1014</sup> Case C-617/10, *Åkerberg Fransson*, ECLI:EU:C:2013:105.

<sup>1015</sup> Case C-476/17, *Pelham and Others*, ECLI:EU:C:2019:624.

is not entirely determined by EU law, national authorities and courts remain free to apply national standards of protection of fundamental rights.

When relying on national fundamental rights as the standard of review for areas in which Member States are afforded latitude, the Federal Constitutional Court can draw on the presumption that constitutional review of national law on the basis of German fundamental rights generally ensures the level of protection required under the Charter as interpreted in the case-law of the Court of Justice.<sup>1016</sup> This presumption arises from overarching links between the Basic Law and the Charter shaped by a common European fundamental rights tradition. Like the general principles of law, which are equivalent to fundamental rights and were initially developed through the case-law of the CJEU, the Charter relies on the different constitutional traditions of the Member States too. It combines these, further expands them and channels them into an EU law standard. The different fundamental rights regimes of the Member States have a common foundation in the ECHR, which the EU Treaties as well as the Charter of Fundamental Rights also draw upon, although the EU has not yet acceded to the Convention.

### 3.2 Second Right to be forgotten

Unlike the first *Right to be forgotten* case, the legal background to the second case concerned an area fully determined by EU law, that is, an area in which Member States are not afforded legislative latitude. This case was also originally subject to the Data Protection Directive – today the General Data Protection Regulation –, but unlike the first case it concerned the fully harmonised part of data protection law. The legislative latitude afforded the Member States under EU law was not applicable here, since the data in question had been processed by a search engine operator, and therefore did not serve ‘journalistic’ purposes within the meaning of the media privilege.

The key findings of our Court’s decision in that case can be summarised as follows. To the extent that fundamental rights of the Basic Law are inapplicable due to the precedence of application of EU law, the Federal Constitutional Court reviews the domestic application of EU law by German authorities on the basis of EU fundamental rights.<sup>1017</sup> Therefore, it is in line with the Federal Constitutional Court’s established case-law that German fundamental rights are not applicable in a review concerning the validity of legislation fully harmonised under EU law. The same holds true where the review concerns the application of such legislation in practice. Where the EU, acting within its competences, enacts legislation that is binding and must be applied uniformly throughout the EU, the fundamental rights protection afforded in this context must be based on uniform standards too, as the Court of Justice clearly explained in the *Melloni* case. The EU Charter of Fundamental Rights guarantees such uniform protection. In this scenario, German fundamental rights are not applicable because a review based on them would run counter to the objective of legal harmonisation.

---

<sup>1016</sup> BVerfG, Order of the First Senate of 6 November 2019 - 1 BvR 16/13, ECLI:DE:BVerfG:2019:rs20191106.1bvr001613, para. 49.

<sup>1017</sup> Order of the First Senate of 6 November 2019 - 1 BvR 276/17, ECLI:DE:BVerfG:2019:rs20191106.1bvr027617, para. 57.

However, the resulting ‘gap’ in the Federal Constitutional Court’s standard of review in assessing a constitutional complaint is closed by directly relying on EU fundamental rights. In other words, the Federal Constitutional Court directly reviews adherence to EU fundamental rights. Where the Federal Constitutional Court relies on EU fundamental rights as the relevant standard of review, it seeks cooperation with the CJEU and, if doubts arise regarding the correct interpretation of EU fundamental rights, requests a preliminary ruling from the Court of Justice pursuant to Article 267 of the Treaty on the Functioning of the European Union (TFEU).<sup>1018</sup> In our case, the decisive issue was whether the court of last instance, in applying ordinary law, had sufficiently taken into account EU fundamental rights and had conducted a tenable balancing in this regard. Ultimately, the challenged rejection of the action was within the margin of appreciation afforded to ordinary courts.

## 4 European Arrest Warrant III & Ecotoxicity

This case-law was consolidated further in the decisions *European Arrest Warrant III*<sup>1019</sup> and *Ecotoxicity*<sup>1020</sup>. Both decisions also illustrate how the new case-law of the Federal Constitutional Court has a practical impact on the review of fundamental rights violations.

## 5 Summary

It is true that the aforementioned decisions do not resolve all questions. But the Federal Constitutional Court, in realigning its case-law regarding the fundamental rights protection in the European multi-level system, has contributed to the necessary and desirable dialogue of the courts. Its contribution could be summarised as follows:

3. diversity of national fundamental rights protection where possible – European uniformity of fundamental rights where necessary;
4. the Basic Law’s assurance that the Constitutional Court give specific effect to fundamental rights protection must be comprehensively honoured in all areas of law, also taking the standards of the Charter of Fundamental Rights into account where necessary; and
5. in areas determined by EU law, the Federal Constitutional Court ensures fundamental rights protection, where necessary in cooperation with the Court of Justice.

---

<sup>1018</sup> Order of the First Senate of 6 November 2019 - 1 BvR 276/17, ECLI:DE:BVerfG:2019:rs20191106.1bvr027617, para. 68.

<sup>1019</sup> BVerfG, Order of the Second Senate of 1 December 2020 - 2 BvR 1845/18, ECLI:DE:BVerfG:2020:rs20201201.2bvr184518.

<sup>1020</sup> BVerfG, Order of the Second Senate of 27 April 2021 - 2 BvR 206/14, ECLI:DE:BVerfG:2021:rs20210427.2bvr020614.

## 6 Possibilities of review reserved by the Federal Constitutional Court

My account of the close cooperation between the Federal Constitutional Court and the CJEU with regard to fundamental rights protection (and beyond) would be incomplete – especially when given at this institution – if I did not also mention a disagreement between the two institutions, which came to the surface just a few months after the Federal Constitutional Court issued its two *Right to be forgotten* decisions, but which in principle has existed for more than half a century.

To be very clear, the Federal Constitutional Court does not question the precedence of application of EU law over national law (including constitutional law), nor does it question the fact that the Court of Justice has the final say on the interpretation of EU law. On the contrary, the Federal Constitutional Court was the very first constitutional court to recognise the fundamental principle that EU law also enjoys precedence of application over national constitutional law. In order for the EU to operate as a single area of justice, it is absolutely imperative that legislation adopted jointly at that level not be applied and interpreted differently in the 27 Member States. However, this premise is not without exception. In accordance with both the European Treaties and the Basic Law, the precedence of application of EU law is based on the transfer of sovereign powers by the Member States. In this regard, Article 1(1) of the Treaty on European Union (TEU) provides: “[b]y this Treaty, the High Contracting Parties establish among themselves a European Union [...], on which the Member States confer competences to attain objectives they have in common.” In addition, Article 5(2) of the TEU specifies: “[u]nder the principle of conferral, the Union shall act only within the limits of the competences conferred upon it by the Member States in the Treaties to attain the objectives set out therein. Competences not conferred upon the Union in the Treaties remain with the Member States.” Thus, the Treaties themselves already make clear that the Member States remain the ‘masters of the Treaties’ and that the EU’s competences are based on a transfer of sovereign powers by the Member States. Similarly, Article 23(1) of the Basic Law provides that, “with a view to establishing a united Europe, Germany shall participate in the development of the European Union that is committed to democratic, social and federal principles and to the principle of subsidiarity and that guarantees a level of protection of fundamental rights essentially comparable to that afforded by this Basic Law. To this end the Federation may transfer sovereign powers by a law with the consent of the *Bundesrat*.” Broadly speaking, the precedence of EU law only applies to the extent that the Basic Law and the domestic act of approval permit or provide for a transfer of sovereign powers. It is incumbent upon the Federal Constitutional Court to ensure respect for these constitutional limits.

In exercising this mandate in the context of European integration, the first instrument on which the Federal Constitutional Court relies is the *ultra vires* review. When conducting an *ultra vires* review, the Federal Constitutional Court assesses whether measures of European institutions, bodies or other agencies respect the limits of the competences transferred to the EU as determined by the national legislator. The Federal Constitutional Court comprehensively addressed this question as early as 1993, in its decision concerning the Treaty of Maastricht. Back then, it drew on its earlier case-law to find that “[i]f European institutions or bodies were to handle or



develop the TEU in a manner that is no longer covered by the Treaty underlying the German act of approval, the legal acts following therefrom would not be binding in Germany's sovereign sphere. Constitutional law would then preclude German state organs from applying these legal acts in Germany. The Federal Constitutional Court thus reviews whether legal acts of the European institutions and bodies remain within the boundaries of the sovereign powers transferred to them or whether they cross these boundaries."<sup>1021</sup> In its decision from 2009, endorsing the Treaty of Lisbon in principle, the Court expressly made clear that it is under an obligation to review whether a legal act of the EU is within the competences transferred to it: this review serves to ensure respect for the order of competences laid down in the Treaties and in the Basic Law.<sup>1022</sup>

In the context of all these decisions, the Federal Constitutional Court has always been aware that a single area of justice such as the EU requires the uniform application and enforcement of jointly adopted legislation. For this reason, it highlighted in its *Honeywell* decision from 2010 that an *ultra vires* challenge can only be successful if, firstly, the challenged actions of the EU clearly breach its competences, secondly, if they result in structurally significant shifts in the division of competences to the detriment of the Member States and, thirdly, if the Court of Justice was given the opportunity to interpret the Treaties and rule on the validity and interpretation of the acts in question in the framework of the preliminary ruling procedure, provided that the issues raised have not already been settled in the case-law of the Court of Justice.<sup>1023</sup> The Federal Constitutional Court thus deliberately applies a strict standard for finding that an act is *ultra vires*.

The second instrument that the Federal Constitutional Court uses in this context is the review on the basis of constitutional identity (so-called identity review). When conducting an identity review, the Federal Constitutional Court examines whether the principles declared inviolable by Article 79(3) of the Basic Law are affected by a measure of the EU. Article 79(3) of the Basic Law provides that any amendment to the Basic Law is impermissible if it affects the federal principle with its vertical separation of powers, the inviolability of human dignity, or the principles of democracy, the social state and the rule of law. Since the Basic Law bars the legislator from making amendments that affect this constitutional identity, the legislator may not transfer sovereign powers to the EU that encroach on this core constitutional identity. This is expressly set out in Article 23(1) third sentence of the Basic Law. In practice, a real conflict will be the rare exception. After all, the EU is a community based on democratic values and the rule of law, which is – not least thanks to the case-law of the Court of Justice – characterised by a high level of fundamental rights protection. Moreover, the enhanced dialogue with the Court of Justice on the protection of fundamental rights in the EU, which the Federal Constitutional Court has fostered with its decisions in *Right to be forgotten* and its subsequent decisions *European Arrest Warrant III* and

---

<sup>1021</sup> BVerfG, Judgment of the Second Senate of 12 October 1993 - 2 BvR 2134, 2 BvR 2159/92.

<sup>1022</sup> BVerfG, Judgment of the Second Senate of 30 June 2009 - 2 BvE 2/08, ECLI:DE:BVerfG:2009:es20090630.2bve000208, para. 240.

<sup>1023</sup> BVerfG, Order of the Second Senate of 6 July 2010 - 2 BvR 2661/06, ECLI:DE:BVerfG:2010:rs20100706.2bvr266106, paras. 58-61.

*Ecotoxicity*, has the potential to help avoid a legally significant divergence of fundamental rights standards.

## 7 Conclusion

The Court of Justice remains an important guarantor for safeguarding the EU as a community of law, but it is not the only actor within the multi-level cooperation of European courts. Even if the various actors have different tasks – the Court of Justice has the final say on the interpretation of EU law, while the Federal Constitutional Court is responsible for ensuring adherence to the Basic Law’s requirements regarding European integration –, they are united by a common goal: ensuring that the rule of law prevails within our unique multi-level framework, in which conventional judicial categories of hierarchy, supremacy and subordination are not sufficient to describe the relationship between the Court of Justice and the national constitutional courts.

The Basic Law’s commitment to so-called ‘open statehood’ was a bold and forward-looking decision by the German constitutional legislator. The foresight demonstrated by the fathers and mothers of the Basic Law cannot be overestimated. With the objective laid down in the preamble – to promote world peace in a united Europe –, they paved the way for European integration, and thus for prosperity and lasting peace in Europe. Despite all the challenges we currently face, I am confident that the Basic Law’s commitment to Germany’s integration within international contexts is an important precondition for a successful future of our country and our constitutional order. Furthermore, the case-law of the Federal Constitutional Court demonstrates that this integration need not be detrimental either to the identity of the national Constitution or to the protection of the fundamental rights of the individual.



# Concluding Synopsis

Chiara Zilioli\*

## Introduction

The title of the ECB Legal Conference 2023 and of this volume is: *[Treading softly:] How central banks are addressing current global challenges*. In 2021 the theme of the ECB Legal Conference was how the challenges we were facing at the time would prepare the ground for tomorrow. Our resolve back then was to look to the future with confidence and hope that the defining challenge of that time, the coronavirus (COVID-19) pandemic, would be overcome, and our societies would emerge stronger and more resilient. Fortunately, COVID-19, at the time of writing, has an awkward feeling of something no longer worth bothering too much about, and this is the best sign that our hopes were not in vain. Unfortunately, new challenges have emerged, and others which had already been there prior to the pandemic came back on the agenda.

The defining challenge of the year preceding the organisation of the conference was Russia's aggression towards Ukraine, which brought back war in Europe at a scale which we have not experienced probably since World War II. The minds and preoccupations of people all around the world have focused on this conflict for more than a year and a half now. Also the central bank world has been called to contribute, and we devoted a discussion to the developments in the field of international sanctions, a topic which is further analysed in Part four of this volume. We could not imagine at our conference that in a month's time a new war would have started in the near East. Our sincere hope is that both of these challenges will have been overcome by the time we organise our next conference, and that peace will have prevailed.

Climate change is a challenge which unfortunately is not going to disappear any time soon and can be considered the defining challenge of our age. It should be of no wonder that you can find references to it in several parts of this volume, and I suspect that climate change is going to feature prominently also in our next conferences, and rightly so.

Other challenges that we analyse in this volume are fortunately less dramatic. Yet they are not less worth being seriously addressed, as they relate to the relationship between the legislator and the authorities in charge of safeguarding monetary and financial stability, and the impact that recent developments have had on the concept of monetary sovereignty.

What all these challenges have in common is that they are global in nature: they trigger concerns all around the globe, yet none is able to solve them alone. The risk of these situations is that nobody feels responsible to address them. We argue that all are

---

\* Director General Legal Services, European Central Bank, Professor at the Law Faculty of the Goethe University in Frankfurt am Main.

called to do their part, and a special role is to be played (and is played) by central banks.

Central banks are inherent anchors of stability of the societies they are part of. The general opinion is that their role is to advance the values of the past, but we see them instead as custodians of the world we inherited. We feel a responsibility to pass it on to the next generations, and the caution which central banks use is because we tread on their dreams<sup>1024</sup>.

## Overview of the contributions

This volume opens with the thoughts of our Executive Board member **Frank Elderson** on the increasing significance of climate-related litigation, drawing from the insights of a recent report published by the Network of Central Banks and Supervisors for Greening the Financial System. He highlighted how the obligations related to climate change, as outlined in the Paris Agreement, are extending beyond nation States to encompass private entities, including corporations, due to notable legal cases like *Urgenda*. Banks are not exempt from these shifts, and climate litigation is progressively posing a risk to the stability of banks' financial positions. In line with these premises, he stressed that it is imperative for banks to develop ambitious yet practical strategies to manage and mitigate their exposure to this risk. At the same time, he concluded, banking supervisors should ensure that banks take all necessary action.

Part two of the book focuses on "**Independence, accountability and proportionality in the context of the ESCB's secondary mandate**". In his contribution, **Alexander Thiele** framed the question in terms of a trade-off between a narrow interpretation of the secondary mandate and a narrow interpretation of the ECB's independence (when carrying out tasks in connection with the secondary mandate). **Klaus Tuori** proposes a comprehensive analysis of the development of the ECB's role in a constitutional perspective, taking the opportunity in particular to caution against the excessive and improper use of the principle of proportionality as a benchmark for the judicial review of the ECB's actions, especially in the field of monetary policy. Although it is not possible to draw conclusions at this stage, in many cases, distinguishing in practice between the two different objectives would pose considerable challenges and require arguing against the Treaty's wording, which does not differentiate between various legislative standards.

Part three of the book focuses again on the challenges connected with climate change and other nature-related harms from a different perspective, i.e. in relation to the "**Incorporation of environmental considerations in the supervision of prudential risks**". In her contribution, **Juliana B. Bolzani** argues that central banks and banking supervisory agencies do not need a new and specific mandate to support a green transition, while at the same time arguing that the nature of environmental considerations warrants a principle-based approach to regulation which requires

---

<sup>1024</sup> As W.B. Yeats wrote: "I have spread my dreams under your feet; Tread softly because you tread on my dreams".

supervisory authorities having a certain scope of discretion. **Veerle Colaert** is instead of the opinion that sustainable finance is not yet an autonomous objective of prudential regulation but has the potential to become one in the future. She also argues that in the case of a conflict between the sustainable finance objective and the traditional objectives, the sustainable finance objective should give way to the traditional objectives of financial regulation. **Suzanne Kingston**, Judge at the General Court, reviews recent developments in prudential and constitutional frameworks respectively to conclude that courts will play an increasingly important role in this field. In particular, she pointed to two roles. The first role is that of the classic judicial review in controlling the legality of supervisors' actions in the field of banking law. The second role concerns climate-related litigation as an increasingly important risk driver for financial institutions, owing to the rapid growth and evolution of such litigation in recent years. This discussion is yet another reminder of the increasing importance of the crossway between courts, legislators, administrative authorities and market players in the collective endeavour to fight climate change.

In Part four of the book, "**Central bank immunities and international sanctions**" are discussed. **Iryna Bogdanova** examines recent practice in several jurisdictions in the aftermath of Russia's aggression towards Ukraine to argue that a review of the prevailing view on State immunity should be warranted. **Ingrid Brunk** cautioned against a sudden twist in the legal treatment of central banks' assets for the purpose of international sanctions, given the potential ramifications of this choice. To conclude, **Richard Ostrander** reviews closely the recent United States' experience to address the question of the treatment of the Russian State's and Central Bank's assets. This discussion shows that there is no clear indication of how this topic will develop in the future, but the issue is certainly crucial for shaping our responses to breaches of international law and for shaping the international order we wish to promote.

The fifth part of the book centres around the topic of "**Monetary sovereignty: meaning and implications**" and examines various aspects of monetary sovereignty through diverse lenses. **Corinne Zellweger-Gutknecht** analyses the concept of monetary sovereignty to then focus on those factors that risk limiting monetary sovereignty at present. Against this background, she examines whether safeguarding monetary sovereignty may be considered as a rationale for issuing central bank digital currencies (CBDCs). **Jens van 't Klooster** analyses the questions surrounding the monetary sovereignty of the EU in connection with the international role of the euro, and he reviews the historical foundations of Economic and Monetary Union to argue that the latter was designed without any particular strategy for promoting the international use of the euro. The joint reading of these contributions shows, once more, how often the past offers enlightening insights to help decode the challenges we face for the future.

The sixth part of the book, titled "**Filling the gaps: central banks, competent authorities and legislative frameworks**", focuses on the advisory role that the central bank performs to the benefit of the legislator, and in particular on the categorisation and real-world developments concerning ECB opinions. **Diane Fromage**, leveraging statistical data, finds that ECB opinions hold greater influence and significance in shaping legislation the closer the matter is to the core

competencies of the ECB. **David Ramos Muñoz** suggests viewing ECB opinions as a form of soft law instrument that fills gaps in legislation, prompting questions about distinguishing cases where the ECB is tasked with enforcing the law and where it is subject to enforcement itself. **Miguel Sampol Pucurull**, Judge of the General Court, delves into the aspects of accountability and justiciability of ECB opinions, drawing comparisons with case-law concerning procedural requirements. This fascinating collection of analyses shows that this is a greenfield area that may deserve further investigation by the doctrine in the future.

The seventh part of this book focuses on “**Preliminary rulings: the past, the present and the future**”. It discusses the legitimacy of the principle of supremacy, which is the foundation of the relationship between the Court of Justice of the European Union (CJEU) and national courts in the preliminary reference procedure. **Sacha Garben** analyses the historical development of preliminary references and identifies an EU constitutional claim that in her opinion would have triggered a “judicial conflict” with national courts. **Vittorio di Bucci** offers a different reading of the historical development of the preliminary reference procedure, whereby the cooperation with, and acceptance by, national courts is highlighted. Against this background, he also brings some considerations for the future institutional developments of the CJEU. **Lucia Serena Rossi**, Judge at the CJEU, moves from the topic of preliminary references to provide a broader overview of judicial protection in the banking union.

The dialogue between judicial authorities at EU and national level is analysed further from a different perspective in Part eight of this book by **Stephan Harbarth**, the President of the German Federal Constitutional Court (GFCC). His analysis focuses on the jurisdiction and jurisprudence of the CJEU and of the GFCC respectively with specific regard to fundamental rights. In his conclusion, he particularly remarks the importance of the multi-level cooperation of European courts.

## Some acknowledgments

This book, and the 2023 ECB Legal Conference on which it is based, owes a great deal to our panellists, chairs and contributors, who actively engaged in insightful discussions and shared their expertise. Special thanks go to our Executive Board member, Frank Elderson, for generously supporting this event.

Heartfelt appreciation is extended to Antonio Riso, the organiser of this year’s conference, who also took care that this book was prepared on time. Antonio is a manager in the ECB Legal Services but also genuinely interested about legal doctrine and its developments. He worked tirelessly from the outset to shape the programme and, throughout the conference, to ensure seamless operations. Antonio was supported by a team of colleagues who worked hard for our common endeavour. Among them, I would like to express my gratitude to Carlo Martinoia for meticulously editing all the contributions, and to Monica Bermudez Leyva and Sophia Merker for their exceptional dedication and energy throughout the conference and the phases that preceded and followed its organisation. Lastly, I would like to mention the efforts of many other colleagues both in the Legal Services and other areas of the ECB who

provided technical support: their role was key to ensure the conference's smooth operation and the ultimate production of this book. Although naming them all is not feasible, their individual contributions are deeply appreciated.





# Biographies

## Frank Elderson

Frank Elderson is a member of the Executive Board of the European Central Bank. He oversees the ECB's Legal Services and is Vice-Chair of the ECB's Supervisory Board.

Mr Elderson previously served as Executive Director of De Nederlandsche Bank (DNB). At DNB he held several senior positions before joining its Governing Board in 2011.

Frank Elderson co-chairs the Task Force on Climate-related Financial Risks of the Basel Committee on Banking Supervision. From January 2018 to January 2022 he served as the first Chair of the newly founded Network of Central Banks and Supervisors for Greening the Financial System.

Mr Elderson studied various courses at the University of Zaragoza, Spain. He graduated in Dutch law at the University of Amsterdam in 1994 and obtained an LL.M. Degree at Columbia Law School, New York, in 1995.



## Sacha Garben

Sacha Garben is Professor of EU law at the Legal Studies Department of the College of Europe, Bruges. She is furthermore a replacement judge at the Amsterdam Court of Appeal and is on leave from the European Commission.

She has published widely on a range of substantive and constitutional aspects of EU law and the process of European integration. She is interested in the legitimacy of authority in the EU, and has in that context investigated themes such as the imbalance between social and economic rights, the division of competences between the EU and the Member States and the constitutionalisation of EU law. She is General Editor of the OUP Online Encyclopedia of EU Law, and contributes to leading EU law handbooks and legal commentaries.

She is a graduate from Maastricht University, holds an LLM from the College of Europe and a PhD from the European University Institute in Florence.



## Vittorio Di Bucci

Born in 1963 in Asti (Italy), Mr Di Bucci studied law at the Università degli Studi di Torino (University of Turin, Italy), where he obtained a Master's degree in law in 1986. He continued his studies at the université de Nancy II (University of Nancy II, France) where he obtained a postgraduate degree in Community law in 1988.

In 1987, Mr Di Bucci joined the Court of Justice as a lawyer-linguist in the Italian translation unit. In 1988, he was recruited by Judge G. Federico Mancini as Legal Secretary within his chambers, a position he held until 1991. He was Legal Secretary to Judge Mancini again between 1994 and 2000.

Between 1991 and 1994, Mr Di Bucci was a member of the Transport, Environment and Consumer team of the Legal Service of the European Commission, an institution which he joined again in 2000 as a member of the State Aids and Dumping team of its Legal Service. Between 2007 and 2010, he was a member of, and then Legal Adviser in, the Competition team. In 2010, he was appointed Principal Legal Adviser in the State Aids and Dumping Team and held the same position in the Business Law Team from 2014 to 2023.

On 5 June 2023, Mr Di Bucci was elected Registrar of the General Court.

He is the author of various publications on EU law, in particular on proceedings before the EU Courts, State Aid and EU banking law.



## Lucia Serena Rossi

Since 8 October 2018, Lucia Serena Rossi is a Judge at the Court of Justice of the European Union where she is currently the President of the IXth Chamber.

She graduated in law from the University of Bologna in 1982 and achieved a PhD in European law. She is currently on leave from the academic position of Full Professor of European law at the University of Bologna where she was also the Director of the International Research Centre on European law. She has been a Visiting Professor and Visiting Lecturer in many universities worldwide and is currently teaching at College of Europe in Bruges.

She became a Lawyer at the Bologna Bar in 1985. She is also a Member of several Scientific Councils and Boards as well as the author of more than 130 academic publications in various fields of EU law.



## Philip Lane

Philip R. Lane joined the European Central Bank as a Member of the Executive Board in 2019. He is responsible for the Directorate General Economics and the Directorate General Monetary Policy. Before joining the ECB, he was the Governor of the Central Bank of Ireland. He has also chaired the Advisory Scientific Committee and Advisory Technical Committee of the European Systemic Risk Board and was Whately Professor of Political Economy at Trinity College Dublin. He is also a research fellow at the Centre for Economic Policy Research. A graduate of Trinity College Dublin, he was awarded a PhD in Economics from Harvard University in 1995 and was Assistant Professor of Economics and International Affairs at Columbia University from 1995 to 1997, before returning to Dublin. In 2001 he was the inaugural recipient of the Bernácer Prize for outstanding contributions to European monetary economics.



## Alexander Thiele

Alexander Thiele is professor for state theory and public law at the Law Faculty of the BSP Business and Law School in Berlin.

Alexander Thiele studied law at the University of Göttingen. He received his doctor's degree in 2006 with a thesis that analysed possible deficits of judicial protection within the European Union, especially as regards the (private) action for annulment. During his following legal traineeship in Hamburg he also joined the European Commission as stagiaire atypique (DG Competition) in Brussels.

After passing his second state exam in 2008 he rejoined the University of Göttingen as a postdoc and began working on his habilitation thesis concerning financial supervision. His research has since then focused on democratic and state theory as well as on the Economic and Monetary Union including institutional aspects of the ECB.

He is full professor at the Law Faculty of the BSP Business and Law School in Berlin since 2021 and regularly holds lectures in Constitutional and European Law. He has published several books including a history of the modern state, an introduction to constitutional history and a textbook on the general theory of state. An introduction to the German Constitution is due to be published at the end of 2023.





## Klaus Tuori

Dr. Klaus Tuori works at the University of Luxembourg, researching the EU economic constitutional model and EU economic constitutional law with a particular focus on the ECB and money. His key publications include two CUP monographs, *The Eurozone crisis - A constitutional analysis* (2014) and *The European Central Bank and the European Macroeconomic Constitution: From Ensuring Stability to Fighting Crises* (2022).

He started his career as a monetary policy economist that culminated in Frankfurt during the designing phase of the ECB and the first two years of the euro. Before returning to academia, he worked extensively in the financial sector, focusing on asset management and sovereign debt markets.



## Stephan Harbarth

Prof. Dr. Stephan Harbarth studied law at Heidelberg University from 1991 to 1996. From 1997 to 1999, he completed his legal traineeship at the Berlin Higher Regional Court. He obtained his doctorate (Dr. jur.) from Heidelberg University in 1998. He attended Yale Law School from 1999 to 2000 and obtained a Master of Laws (LL.M.).

Stephan Harbarth was admitted to the German bar in 2000. From 2000 to 2018, he practised as a lawyer. From 2009 to 2018, he was a member of the German Bundestag. Since 2018, he has been an honorary professor at the Faculty of Law of Heidelberg University.

In November 2018, Stephan Harbarth was appointed Vice-President of the Federal Constitutional Court (Bundesverfassungsgericht) and presiding Justice of the First Senate. Stephan Harbarth has served as President of the Federal Constitutional Court since June 2020.



## Iryna Bogdanova

Dr Iryna Bogdanova is an international law scholar from Ukraine. Currently, she holds a position as a postdoctoral researcher and has been based at the World Trade Institute, University of Bern. Her ongoing research project is financed by the Swiss National Science Foundation.

Over the past years, Dr Bogdanova has published contributions analysing various aspects of economic statecraft, mostly focusing on economic sanctions, their effectiveness and legality under international law. Her recent book explores the legality of unilateral economic sanctions, i.e. those imposed by individual states without authorization of the United Nations Security Council, under international law. One of her latest academic projects is to analyse the possibility of using frozen Russian assets (belonging to the Central Bank and private individuals) for funding Ukraine's reconstruction efforts and the legality of such a move.

Iryna earned her PhD degree (Summa cum Laude) from the Faculty of Law of the University of Berne. Prior to this, she pursued legal studies in Ukraine, Switzerland, Canada and the Netherlands. Dr Bogdanova's previous working experiences are diverse and range from private sector employment to work in international organizations.



## Ingrid (Würth) Brunk

Professor (Wuerth) Brunk is an expert on public international law, transnational litigation, and foreign relations law. Her influential scholarship on foreign sovereign immunity has appeared in leading journals and she has advised governments and private parties on many immunity-related topics, especially central bank immunity.

She currently serves as co-editor-in-chief of the *American Journal of International Law* and as a member of the American Law Institute. She was named as a Reporter for the Restatement (Fourth) of the Foreign Relations Law of the United States and has received numerous honours and fellowships, including the Morehead Scholarship at the University of North Carolina at Chapel Hill, a Fulbright Senior Scholar award, the German Chancellor's Fellowship, election to the German Society of International Law, election to the Order of the Coif, and many teaching awards. She is a contributing editor at [Lawfare](#) and a founding editor of the [Transnational Litigation Blog](#).



## Rick Ostrander

Rick Ostrander is the general counsel and the head of the Legal Group at the Federal Reserve Bank of New York. He oversees the day-to-day operations of the group, which include Legal, Compliance, Bank Applications, Group Operations and Strategy, and Records Management. He is also a member of the Bank's Executive Committee and serves as deputy general counsel of the Federal Open Market Committee.

Mr. Ostrander joined the New York Fed in 2022. He previously was a managing director in Legal & Compliance at BlackRock, where he oversaw legal coverage of trading activities and technology products. He also served as a member of several risk and oversight committees and was a champion of L&C's diversity, equity, and inclusion initiatives.

Prior to joining BlackRock in 2011, Mr. Ostrander was a managing director at Morgan Stanley, responsible for global legal coverage of the firm's fixed income division. He started his legal career as an associate at Cleary Gottlieb in 1995.

Mr. Ostrander holds a bachelor's degree from Hamilton College, an MBA from Stanford University's Graduate School of Business, and a JD from Stanford Law School.



## Edouard Fernandez-Bollo

Following his post-graduate studies at the École normale supérieure de Saint-Cloud in the humanities and social sciences section, and after acquiring experience in several branches of the French civil service, Edouard Fernandez-Bollo joined the Banque de France in 1988. There he held various positions related to banking regulation and licensing, European harmonisation and banking resolution issues.

Mr Fernandez-Bollo became General Counsel of the Commission Bancaire, the French supervisory authority, in 2004 and Deputy Secretary General in 2008. From 2007 to 2020 he was Chair of the Basel Committee's expert group on anti-money laundering and combating the financing of terrorism. From 2010 to 2013 he was Deputy Secretary General of the new Autorité de contrôle prudentiel et de résolution (ACPR), the integrated French prudential supervisor, and from 2014 to August 2019 he was Secretary General of the ACPR, a member of the Management Board of the European Banking Authority and a member of the Basel Committee on Banking Supervision.

Mr Fernandez-Bollo began his five-year term as a member of the Supervisory Board of the ECB in September 2019.



## Diane Fromage

Diane Fromage is Professor of European Law and Deputy Director of the Salzburg Centre of European Union Studies (SCEUS) of the University of Salzburg, Austria. She was previously a Marie Skłodowska-Curie Individual Fellow at the Law School of Sciences Po, Paris and an Assistant Professor in EU law at the Universities of Maastricht and Utrecht, The Netherlands. Her research focuses on the Economic and Monetary Union and especially the Banking Union, as well as on democracy within the EU.



## David Ramos Muñoz

David Ramos Muñoz is a Professor at Universidad Carlos III de Madrid, and he also collaborates regularly with the University of Bologna as an Adjunct Professor. He is a member ad personam of the Academic Board of the European Banking Institute, where he leads its Working Group on Finance, Climate Change and Sustainability, and a member of the European Law Institute.

His research encompasses fields like finance, climate change and sustainability, banking crises, and the role of general principles of law in financial architecture, including central banking, supervision or bank insolvency and resolution. He has also conducted research on Private Law and dispute resolution.

As part of his non-research activities he is currently an alternate member of the Appeal Panel of the Single resolution Board, the Joint Board of Appeal of the European Supervisory Authorities, provides advice to the European Parliament on matters of bank resolution, and is part of the UNIDROIT Working Group on Bank Insolvency.

He holds degrees in Law and Business Administration, and a PhD from the University of Bologna





## Miguel Sampol Pucurull

Born in 1974 in Barcelona (Spain), Mr Miguel Sampol Pucurull graduated in law in 1997 and, in 1998, in business administration at the Universidad Pontificia Comillas – ICADE (Comillas Pontifical University, Spain).

He began his career as Abogado del Estado: from 2002 to 2005, he represented the State before Spanish courts before joining, from 2005 to 2006, the Legal Service of the Spanish Ministry of Culture. From 2006 to 2007, he joined the Legal Service of the Spanish Ministry of Foreign Affairs responsible for matters relating to the Court of Justice of the European Union.

From 2007 to 2014, Mr Sampol Pucurull held the post of Abogado del Estado-Legal Adviser to the Spanish Permanent Representation to the European Union. In 2014, he began to work for the Spanish Ministry of Justice as Deputy Director-General for EU and International Affairs at the Abogacía General del Estado (State Legal Service). In that capacity, he served at the Spanish Ministry of Foreign Affairs and Cooperation as Head Abogado del Estado of the State Legal Service responsible for cases before the Court of Justice of the European Union until 2019. During that period, he was also a member of the board of directors of a number of state-owned undertakings and his practice of law led to the writing of numerous legal publications.

Mr Sampol Pucurull was appointed as a Judge at the General Court on 26 September 2019.



## Isabel Schnabel

Isabel Schnabel has been a Member of the Executive Board of the European Central Bank (ECB) since 2020 and is responsible for Market Operations, Research and Statistics. She is currently on leave from the University of Bonn, where she has been Professor of Financial Economics since 2015. From 2014 to 2019 she served as a member of the German Council of Economic Experts, and in 2019 she was CoChair of the Franco-German Council of Economic Experts. She holds a PhD in Economics from the University of Mannheim. Her academic work focuses on financial stability, banking regulation, international capital flows and economic history.



## Veerle Colaert

Prof. dr. Veerle Colaert holds the chair for financial law at KU Leuven University and is co-director of the Jan Ronse Institute for Company and Financial Law. She teaches several courses on financial regulation and organises quarterly legal “Clinics on European Financial Law” for LL.M students and legal practitioners on topical financial law subjects. She is the chair of the Securities and Markets Stakeholders Group (SMSG) advising ESMA and a member of the Belgian Resolution Authority. Formerly she has been a member of the Sanctions Commission of the Belgian Financial Services and Markets Authority (FSMA). Before joining academia, she was an attorney at the Brussels’ Bar. She has published numerous contributions on financial regulation and is a regular speaker at international and national conferences. Her main research interests relate to investor protection, sustainable finance, Banking Union, and the interplay between different legal frameworks.



## Juliana Bolzani

Juliana Bolzani is senior counsel at the International Monetary Fund (IMF).

She works at the Fiscal and Financial Unit of the IMF's Legal Department, which provides legal advice to member countries on the design and implementation of legal reforms, including those related to central banking, payment systems, financial markets, and financial institutions.

Previously, she was a lawyer at the Central Bank of Brazil for over twenty years, advising on issues concerning monetary policy, payment systems, management of foreign reserves, central-bank governance, fintech, digital currencies, and central banks' role in the green transition. She also worked as a litigator representing the Central Bank in federal courts.

Juliana is admitted to practice law in Brazil and New York and is a member of the Chartered Institute of Arbitrators (CI Arb). She holds an LL.M. in international dispute resolution from the University of London and an LL.M. from Duke University, where she is currently a doctoral candidate. Her academic work focuses on the contours of central-bank independence and the evolution of central banks' legal mandates.



## Suzanne Kingston

Born in 1977 in Dublin (Ireland), Ms Suzanne Kingston graduated in law from Oxford University (United Kingdom) in 1998 and obtained a master's degree in law at Universiteit Leiden (University of Leiden, Netherlands) in 2000. She then began to study for a doctorate in law at that university, and defended her thesis there in 2009.

In 1998, she was admitted as a Barrister at the Honourable Society of Gray's Inn, London (United Kingdom). In 2002, she joined the Brussels office of an international law firm where she practised law until 2004.

Ms Kingston subsequently joined the Court of Justice of the European Union as a legal secretary to Advocate General Leendert Geelhoed, with whom she worked from 2004 to 2006.

Ms Kingston was admitted to serve as a Barrister at the Honourable Society of King's Inns, Dublin (Ireland) in 2007. She has practised law at the Bar of Ireland since 2007 as a Barrister, then as a Senior Counsel.

In addition, Ms Kingston taught law at the University College Dublin (Ireland) as a senior lecturer from 2007 to 2015, then, from 2015, as professor. During her academic career, she also taught at other universities, in particular at Columbia University (United States), Cambridge University (United Kingdom), Universiteit Leiden, and Osgoode Hall Law School of York University in Toronto (Canada). She is the author of numerous publications in EU law.

Ms Kingston was appointed as a Judge at the General Court on 13 January 2022.



## Jens van 't Klooster

Jens van 't Klooster is Assistant Professor of Political Economy at the University of Amsterdam. His research focuses on the governance of financial markets, with a specific focus on how climate change and new macroprudential ideas are reshaping the fields of monetary policy and banking supervision. His research is multidisciplinary in orientation and his work has appeared in journals such as *Journal of Politics*, *Review of International Political Economy*, *Political Theory*, and *Journal of Common Market Studies*. His most recent publication is 'New strategy, new accountability: The European Central Bank and the European Parliament after the strategy review' (*Common Market Law Review*; with Seraina Grünewald) Jens holds a PhD in Philosophy (University of Cambridge, 2018) and in Economic policy (University of Groningen, 2021). Before joining the UvA, he was a Max Weber Fellow at the European University Institute in Florence (2018-2019) and a FWO Postdoctoral Fellow at KU Leuven (2019-2022). He is currently also a visiting fellow at LSE's The Grantham Research Institute on Climate Change and the Environment.



## Corinne Zellweger-Gutknecht

Corinne Zellweger-Gutknecht is a professor of private law and economic law at the University of Basel. She is also an adjunct professor at the University of Zurich and a professor at Kalaidos University of Applied Sciences. Prior to that, she served as an associate professor of banking and financial law at the University of Geneva. She researches in the fields of monetary and central banking law and private law. She is particularly interested in cross-disciplinary issues between private and financial market law, the influence of digitization on public as well as private money, payment systems and the financial market, and in the consequences of insolvency on crypto assets. Among others she is a member of an interdisciplinary research group recently set up by TA Swiss on the subject of the digital franc and a member of the Steering Committee to the UNIDROIT Digital Assets and Private Law Working Group.



## Chiara Zilioli

Chiara Zilioli has dedicated her entire working life to the European integration project. In 1989 she joined the Legal Service of the Council of Ministers in Brussels, moving to the Legal Service of the European Monetary Institute in 1995 and subsequently to the ECB as Head of Division in Legal Services in 1998, where she was appointed Director General in 2013.

Ms Zilioli holds an LLM from Harvard Law School and a PhD from the European University Institute. Since 1994 she lectures at Goethe University Frankfurt, at its Institute for Law and Finance and at the European College of Parma, Parma University. In 2016 she was appointed Professor of Law at Goethe University Frankfurt. She has published numerous articles and four books. She is also a member of the Parma Bar Association.

Chiara Zilioli has been married to Andreas Fabritius for more than 30 years; they have four children.





© **European Central Bank, 2023**

Postal address 60640 Frankfurt am Main, Germany  
Telephone +49 69 1344 0  
Website [www.ecb.europa.eu](http://www.ecb.europa.eu)

All rights reserved. Reproduction for educational and non-commercial purposes is permitted provided that the source is acknowledged.

These papers should not be reported as representing the views of the European Central Bank (ECB) or the Eurosystem. The authors are solely responsible for the wording contained therein, and the views expressed do not necessarily reflect those of the ECB or the Eurosystem.

For specific terminology please refer to the [ECB glossary](#) (available in English only).

PDF ISBN 978-92-899-6310-7, ISSN 2467-0057, doi: 10.2866/555825, QB-BX-24-001-EN-N  
Print ISBN 978-92-899-6311-4, ISSN 2467-0049, doi: 10.2866/8913, QB-BX-24-001-EN-C

