

T2-T2S CONSOLIDATION

USER REQUIREMENTS DOCUMENT

FOR

COMMON COMPONENTS~~SHARED SERVICES~~

-ANNEX FOR CENTRAL BANKS ONLY-

Version:	1.1.2
Status:	DRAFT
Date:	xx/xx/2018

Contents

1	BILLING (BILL)	5
1.1	Overview	5
1.1.1	<i>Context Diagram</i>	5
1.1.2	<i>Business Processes</i>	6
1.1.3	<i>Billing Process - Terms and definitions used</i>	7
1.1.4	<i>Billing Process – Functional Design</i>	8
1.2	Aggregate Billing Data	11
1.2.1	<i>Business Process Model</i>	11
1.2.2	<i>Process Overview</i>	11
1.2.3	<i>User Requirements</i>	13
1.3	Generate Invoice Data	18
1.3.1	<i>Business Process Model</i>	18
1.3.2	<i>Process Overview</i>	18
1.3.3	<i>User Requirements</i>	18
1.4	Send Consumption File	23
1.4.1	<i>Business Process Model</i>	23
1.4.2	<i>Process Overview</i>	23
1.4.3	<i>User Requirements</i>	24
1.5	Correct Invoice Data Manually	26
1.5.1	<i>Business Process Model</i>	26
1.5.2	<i>Process Overview</i>	27
1.5.3	<i>User Requirements</i>	28
1.6	Regenerate Invoice Data	31
1.6.1	<i>Business Process Model</i>	31
1.6.2	<i>Process Overview</i>	32
1.6.3	<i>User Requirements</i>	32
1.7	Create Invoice	34
1.7.1	<i>Business Process Model</i>	34
1.7.2	<i>Process Overview</i>	34
1.7.3	<i>User Requirements</i>	35
1.8	Send Invoice	39
1.8.1	<i>Business Process Model</i>	39
1.8.2	<i>Process Overview</i>	39
1.8.3	<i>User Requirements</i>	40
1.9	Cancel Invoice	43
1.9.1	<i>Business Process Model</i>	43

1.9.2	<i>Process Overview</i>	43
1.9.3	<i>User Requirements</i>	44
1.10	Direct Debit	47
1.10.1	<i>Business Process Model</i>	47
1.10.2	<i>Process Overview</i>	47
1.10.3	<i>User Requirements</i>	48
1.11	Billing Gather Information	51
1.11.1	<i>Business Process Model</i>	51
1.11.2	<i>Process Information</i>	51
1.11.3	<i>User Requirements</i>	52
1.12	Billing – non-functional requirements	56
1.12.1	<i>Availability</i>	56
1.12.2	<i>Disaster Recovery</i>	56
1.12.3	<i>Performance Requirements</i>	56
2	LEGAL ARCHIVING (LAR)	57
2.1	Overview	57
2.1.1	<i>Context Diagram</i>	57
2.1.2	<i>Business Processes</i>	58
2.2	Collect Information for Legal Archiving	59
2.2.1	<i>Business Process Model</i>	59
2.2.2	<i>Process Overview</i>	59
2.2.3	<i>User Requirements</i>	60
2.3	Gather Information	62
2.3.1	<i>Business Process Model</i>	62
2.3.2	<i>Process Overview</i>	62
2.3.3	<i>User Requirements</i>	63
2.4	Non-functional Requirements for Legal Archiving	63
2.4.1	<i>Availability</i>	63
2.4.2	<i>Disaster Recovery</i>	63
2.4.3	<i>Performance Requirements</i>	64
3	CONTINGENCY SETTLEMENT (CONT)	65
3.1	Overview	65
3.1.1	<i>Context Diagram</i>	65
3.1.2	<i>General Description of Contingency cases</i>	65
3.1.3	<i>General Assumptions for Contingency Settlement</i>	66
3.1.4	<i>User Requirements for Connectivity to the Contingency Settlement</i>	66

3.1.5	<i>User Requirements for Common Reference Data</i>	66
3.1.6	<i>User Requirements for User Interactions with Contingency Services</i>	68
3.1.7	<i>User Requirements for Liquidity Management</i>	71
3.1.8	<i>User Requirements for Mechanisms of the Settlement Flow</i>	73
3.1.9	<i>Non-functional Requirements</i>	74
4	USER INTERACTION	76
4.1	General User Requirements for User Interaction	76
4.1.1	<i>Query</i>	76
4.1.2	<i>Action</i>	76
4.2	User Interaction for Billing	77
4.2.1	<i>Query</i>	77
4.2.2	<i>Action</i>	80
4.3	User Interaction for Common Reference Data Management	81
4.3.1	<i>Query</i>	81
4.3.2	<i>Action</i>	81
4.4	User Interaction for Data Warehouse (DWH)	87
4.4.1	<i>Query</i>	87
4.4.2	<i>Display</i>	91
4.4.3	<i>Action</i>	91
4.5	User Interactions for Business Monitoring	91
4.6	User Interactions for Operational Monitoring	92
5	BUSINESS DATA DEFINITIONS	93
5.1	Entities and Attributes	93

1 BILLING (BILL)

1.1 OVERVIEW

1.1.1 Context Diagram

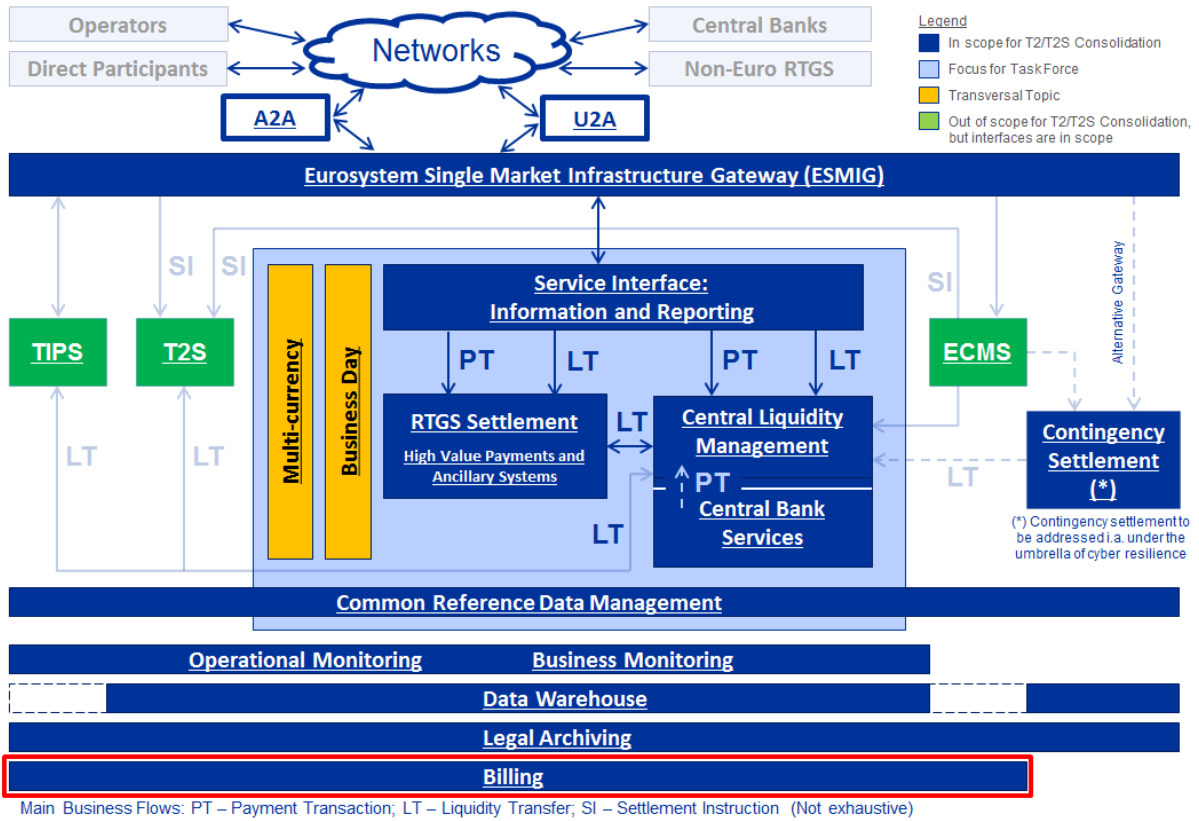

Figure 1: Context diagram for Billing

1.1.2 Business Processes

Business Process	BP Reference	Business Process Description
Aggregate Billing Data	SHRD.CB.BP.BILL.AGBD	Each service, component and application , including RTGS, T2S, TIPS, ECMS, CLM, CRDM, DWH, Contingency Settlement Services and Information and Reporting, produces billable items towards the Billing-service on a daily basis. These billable items are aggregated and enriched to produce consumption data including both traffic and participation data
Generate Invoice Data	SHRD.CB.BP.BILL.GIND	Monthly process to generate invoice data
Send c Consumption f File	SHRD.CB.BP.BILL.SECF	Monthly process to send c Consumption f Files to Central Banks (CBs) including those not making use of the invoicing provided by the Billing-service Note: For CSDs, the process will remain unchanged compared to today
Correct Invoice Data Manually	SHRD.CB.BP.BILL.MACO	Process to adjust invoice data already generated on request
Regenerate Invoice Data	SHRD.CB.BP.BILL.REIN	This process is the re-execution of the generation of invoice data according to rerun parameters after input of manual corrections
Create Invoice (optional)	SHRD.CB.BP.BILL.CRIN	The invoice is created from the invoice data
Send Invoice (optional)	SHRD.CB.BP.BILL.SEIN	The invoice chosen is sent to the billed Party
Direct Debit	SHRD.CB.BP.BILL.SEDD	Optionally, a direct debit according to the invoice is requested
Cancel Invoice (optional)	SHRD.CB.BP.BILL.CAIN	Cancel a chosen invoice
Billing Gather Information	SHRD.CB.BP.BILL.GATH	Provide information to Information and Reporting

Table 1: Business Processes for Billing

1.1.3 Billing Process - Terms and definitions used

Term	Definition
Billing service	Component Service for selecting and packaging billing information, generating invoice data, sending invoice and instructing direct debits
Consumption data / Billable Items	Consumption and events to be billed, e.g. traffic data coming from a <u>Eurosystem</u> Market Infrastructure Service or participation data coming from CRDM
Billing data	Information from <u>Eurosystem</u> Market Infrastructure Services, packaged by the Billing-service according to specific criteria (e.g. filtering, sorting, and aggregation) which can be processed for invoice creation
Consumption file	File containing packaged billing data that can be delivered to system entities or further processed for invoice creation
Invoice data	Billing data enriched with the Party to be billed and the Party to be debited
Fee Originator	Party who has initiated or caused the billable item in the system
Party to be charged	Party to whom the billable item is assigned to due to a contractual agreement
Party to be billed	Addressee of the invoice
Party to be debited	Holder of the account which will be debited with the amounts on the invoice
System entity	CB or CSD in a billing context

Table 2: Billing terms and definitions used

1.1.4 Billing Process – Functional Design

The overall billing process is, from a functional point of view, designed as depicted by the diagram below:

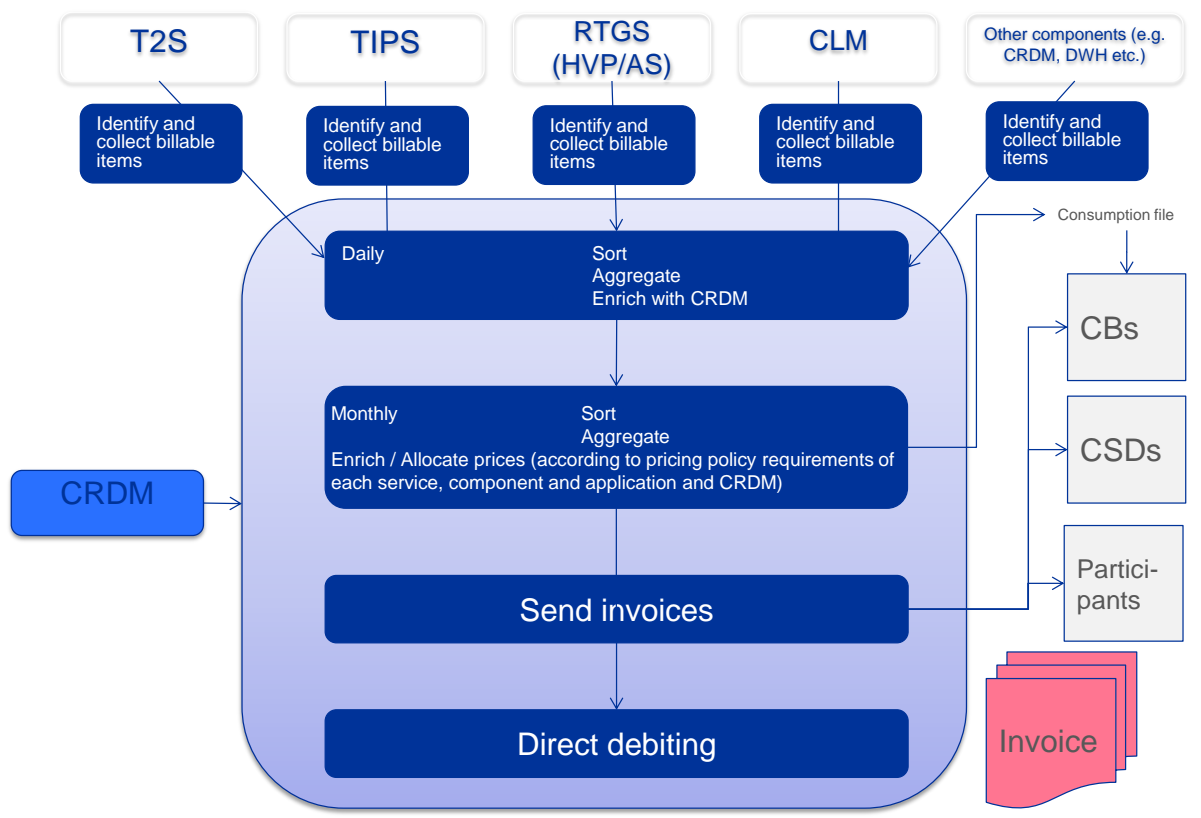

Figure 2: Functional overview of the **B**illing process

A centralised data repository will collect all billable events from all Sservices, components and applications as well as billable information (e.g. participation) from CRDM.¹ The enrichment and aggregation process to prepare the data for billing will happen in the data repository. In short, the data transformation path is as follows:

Consumption Data → Billing Data → Invoice Data → Invoices → Direct Debits.

Note: In the figure above, CRDM is depicted twice. The occurrence on the upper right corner is related to CRDM as a componentService which will produce billable items, whereas the occurrence on the left hand side is related to CRDM as an input for the enrichment and aggregation process within the Billing-service.

¹ If a Party is active on at least one day during the month, there shall be an entry in the billing data for that Party. In addition, MCA to be debited shall be retrieved from CRDM even if this account is closed.

Note: The user requirements below shall impact the invoicing business of CSDs acting as service providers as little as possible, therefore the flow of consumption files to CSDs is not depicted in the diagram above.

1.1.4.1 ENRICHMENT AND AGGREGATION PROCESS

The different ~~settlement~~ services, ~~components and applications and common services~~ will identify and collect the billable items. The ~~S~~services, ~~components and applications~~ will identify the originator of the billable event (e.g. Party instructing the system).

The enrichment and aggregation process will take the information on the Party to be charged from Common Reference Data.

Flexible grouping rules (i.e. different aggregation levels based on pre-specified parameters) shall define how aggregated consumption per participant/account ~~holder~~ will be calculated before applying the respective pricing tables for each ~~S~~service, ~~component or application~~.

Pricing rules will be applied to:

- ▶ Cater for cross-service billable items (e.g., liquidity transfer from one settlement service to another) or billable items from ~~components common services~~;
- ▶ Determine fixed fees and other special treatments (e.g. for discounts, business grouping rules) on the level of a Party, community, or ~~S~~service, on the basis of the set pricing policy; and
- ▶ Cater for cross-country constellations (in order to derive which of the branches to charge).

The process will produce billing information in a standardised format and provide it to the invoice generation process.

1.1.4.2 INVOICING PROCESS

The central Billing ~~components~~service will identify the Party to be billed (i.e. the recipient of the invoice) and the Party and the account to be debited, on the basis of the reference data setup according to the pricing policy of each ~~S~~service, ~~component and application~~.

Once the invoice data is generated, and before invoices are created, CBs for their communities and the ECB in a centralised manner shall be able to manually adjust the billing data. These manual adjustments (billable items, amounts or percentages) shall be logged within the billing information but must not modify existing aggregated billing data. Adjustments to billable items shall include consumption and amount, both could be positive or negative. Amounts and percentages could be positive or negative. After the invoices are sent, the TARGET Service Desk shall be able to regenerate the invoices for all ~~S~~services, ~~components and applications~~ and participants.

System entities (CBs and CSDs) and participants will receive their invoices based on their ~~of~~ parameter configuration.

CSDs will receive invoices for T2S services as system entities, and will continue to use the current process, i.e. querying the itemised billing data to invoice their participants.

Finally, for the Parties for which a direct debit option has been set up in Common Reference Data, the pre-specified Main Cash Accounts (MCAs) will be debited according to the invoices. If the option for automated direct debits has not been chosen, the collection of fees has to be ensured through other, operational means, in agreement between the Party to be debited and the relevant Central Bank. For the cash settlement services, components and applications~~shared services~~ (i.e. not securities settlement services), where an invoice already sent out is legitimately disputed by a customer, the CB can manually create and issue:

- ▶ A reverse invoice and, optionally;
- ▶ A reverse payment order to cancel the initial payment; and
- ▶ A new payment order with the new amount.

Note: Invoicing is always denominated in euro~~EURO~~, including those activities based in other currencies.

1.2 AGGREGATE BILLING DATA

Business Process Ref: SHRD.CB.BP.BILL.AGBD

1.2.1 Business Process Model

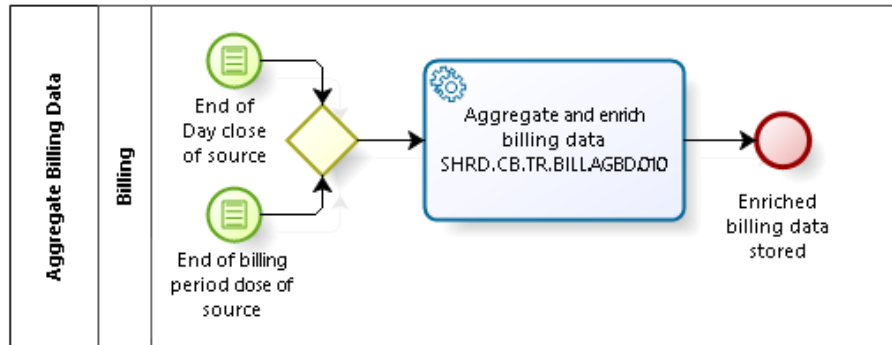

Business Process Model 1: Aggregate Billing Data

1.2.2 Process Overview

Process goal:

This business process describes the enrichment and aggregation of consumption for the different settlement services, components and applications~~common services shared among them (incl. CRDM).~~

The billing process elaborates the billing information for the relevant Party following a bottom-up, sequential approach in terms of aggregation levels, starting with the bill of the individual participant and aggregating further to the bill of a CB or of a CSD, if the pricing policy of the respective Sservice, component or application requires it.

For example, T2S invoices the CBs according to the Parties to be charged for T2S traffic whilst the CBs at their time can only invoice the respective participants according to the Parties to be billed. Therefore, the T2S charges for the cash side will be invoiced as follows:

	1st level of aggregation	2nd level of aggregation	Production of invoice
Participants invoices	P1) Billing data aggregated according to Party to be BILLED.	P2) n/a	P3) Application of pricing and issuance of invoice per participant (Party to be billed)
CBs invoices	B1) Billing data aggregated according to Party to be CHARGED.	B2) = $\Sigma B1$) per CB: Billing data aggregated per CB (accumulation of billing data for all Parties to be CHARGED belonging to a CB).	B3) Application of pricing and issuance of invoice per CB (Party to be billed)
CBs pooling/redistribution data ²	O1) = P1): Billing data aggregated according to Party to be BILLED.	O2) = $\Sigma O1$) per CB: Billing data aggregated per CB (accumulation of billing data for all Parties to be BILLED belonging to a CB).	O3) = O2) - B2) per CB: Application of pricing and issuance to the ECB of a report displaying amounts to be pooled from and redistributed to each CB.

Table 3: T2S invoicing for the cash side

~~TIPS and other Services' invoice creation will equally follow the respective Service's billing policy.~~

Process context:

- ▶ The generic process and its descriptions are valid for all billing data for all ~~S~~services, components and applications.

Pre-conditions:

- ▶ The (elaborated) raw data from the various ~~S~~services, components and applications is available to ~~the Billing service~~.

Time constraints:

- ▶ ~~The Billing service~~ shall perform the daily aggregations before it can start the monthly aggregation.

² Listed here for informational purposes only, as ~~p~~Pooling/redistribution is a different process than billing

Expected results:

- ▶ ~~The Billing service~~ will aggregate and enrich billing data and store it afterwards.

Triggers:

- ▶ The process will be initiated by the End of Day close of service or the End of billing period close of service

1.2.3 User Requirements

1.2.3.1 AGGREGATE AND ENRICH ~~B~~BILLING ~~D~~DATA

Task Ref: SHRD.CB.TR.BILL.AGBD.010

Id	SHRD.CB.UR.BILL.AGBD.010.010
Name	End of Day close of service
Description	An End of Day close of service event shall trigger the daily aggregation and enrichment of S service-specific transactional data.

The aggregation and enrichment of transactional data for a ~~Market Infrastructure S~~service, component or application can only take place after ~~ita Service~~ has completed its processing for a given business day. This ensures that the transactional data that Billing needs to aggregate are complete for the business day for which Billing will generate the aggregated consumption data.

Id	SHRD.CB.UR.BILL.AGBD.010.020
Name	End of Day close of service for TIPS
Description	When TIPS changes its business day, an End of Day close of service event for TIPS shall trigger the daily aggregation and enrichment of instant payment transactional data.

Id	SHRD.CB.UR.BILL.AGBD.010.030
Name	End of Day close of service for the RTGS services
Description	When the RTGS services changes itstheir business day, an End of Day close of service event for the RTGS services shall trigger the daily aggregation and enrichment of the RTGS services transactional data.

Id	SHRD.CB.UR.BILL.AGBD.010.035
Name	End of Day close of service for CLM
Description	When CLM change its business day, an End of Day close of service event for

	CLM shall trigger the daily aggregation and enrichment of CLM transactional data.
--	---

Id	SHRD.CB.UR.BILL.AGBD.010.036
Name	End of Day close of service for Common Components Shared Services
Description	When each Common Component Shared Services changes its business day, an End of Day close of service event for this component Shared Services shall trigger the daily aggregation and enrichment of the component's Shared Services data.

Id	SHRD.CB.UR.BILL.AGBD.010.040
Name	End of Day close of service for T2S
Description	When T2S changes its business day, an End of Day close of service event for T2S shall trigger the daily aggregation and enrichment of T2S transactional data.

Id	SHRD.CB.UR.BILL.AGBD.010.045
Name	End of Day close of service for ECMS
Description	When ECMS changes its business day, an End of Day close of service event for ECMS shall trigger the daily aggregation and enrichment of ECMS transactional data.

Id	SHRD.CB.UR.BILL.AGBD.010.050
Name	End of billing period close of service
Description	An End of billing period close of service event shall trigger the finalisation of the aggregation and enrichment of S service-specific data.

Id	SHRD.CB.UR.BILL.AGBD.010.060
Name	End of billing period close of service for TIPS
Description	When TIPS changes its business day on the last business day of a billing period, an End of billing period close of service event for TIPS shall trigger the finalisation of the aggregation and enrichment of instant payment data.

Id	SHRD.CB.UR.BILL.AGBD.010.070
Name	End of billing period close of service for CLM
Description	When CLM changes its business day on the last business day of a billing period, an End of billing period close of service event for CLM shall trigger the finalisation of the aggregation and enrichment of CLM data.

Id	SHRD.CB.UR.BILL.AGBD.010.075
Name	End of billing period close of service for the RTGS services
Description	When the RTGS services changes its business day on the last business day of a billing period, an End of billing period close of service event for the RTGS services shall trigger the finalisation of the aggregation and enrichment of the RTGS services data.

Id	SHRD.CB.UR.BILL.AGBD.010.080
Name	End of billing period close of service for T2S
Description	When T2S changes its business day on the last business day of a billing period, an End of billing period close of service event for T2S shall trigger the finalisation of the aggregation and enrichment of T2S data.

Id	SHRD.CB.UR.BILL.AGBD.010.085
Name	End of billing period close of service for ECMS
Description	When ECMS changes its business day on the last business day of a billing period, an End of billing period close of service event for ECMS shall trigger the finalisation of the aggregation and enrichment of ECMS data.

Id	SHRD.CB.UR.BILL.AGBD.010.090
Name	Identification of Party to be charged
Description	<p>Billing shall derive from <u>sService-specific</u> data and include the following information:</p> <ul style="list-style-type: none"> • The Party to be charged for each billable item (e.g. account <u>holderowner</u>), (Originator and charged Party can be different entities) <p>The information added comes from Common Reference Data.</p>

Id	SHRD.CB.UR.BILL.AGBD.010.100
Name	Consumption data target format
Description	<p>Billing shall process consumption data structured as follows:</p> <ul style="list-style-type: none"> • Service/<u>component/application</u> the consumption data stems from; • Business date; • Billable item; • Grouping classification for billable items (e.g. settlement, information, account management); • Account of the underlying transaction; • Account holder of the aforementioned account; • Party originating the billable item; • Party to be charged for the billable item; • Total count of the billable item; and • System entity (CB/CSD) of the Party to be charged. <p>The data structure is standardised for all settlement services, <u>components</u> and <u>applicationsecommon-services</u>.</p>

Note: An individual transaction can generate more than one billable item.

Id	SHRD.CB.UR.BILL.AGBD.010.110
Name	Aggregate consumption (First Level)
Description	<p>Billing shall allow for flexible grouping (i.e. aggregation based on pre-specified parameters) based on:</p> <ul style="list-style-type: none"> • Service/component/application; • Party to be charged; • System entity of the Party to be charged; • Billable item; and • Grouping of billable items.

Note: Through tracing "Party originating the billable item" and "Party to be charged", a distinction between one's "own" traffic and the billable items "created" by other participants is possible.

Id	SHRD.CB.UR.BILL.AGBD.010.120
Name	Aggregate charges (Second Level)
Description	Billing shall allow for aggregation of aggregations derived on the first level.

An aggregation on the second level will be based on the system entity to which the Party to be charged from the first aggregation level is attached to. The second level of aggregation and possible subsequent levels shall follow the requirements of the pricing policy and contractual requirements of each [Service, component or application](#).

Id	SHRD.CB.UR.BILL.AGBD.010.130
Name	Store enriched billing data
Requirement	<p>Billing shall store the enriched billing data and relevant information related to it:</p> <ul style="list-style-type: none"> • The status of the data stored; • Date; • Billing period; and • Service/component/application.

1.3 GENERATE INVOICE DATA

Business Process Ref: SHRD.CB.BP.BILL.GIND

1.3.1 Business Process Model

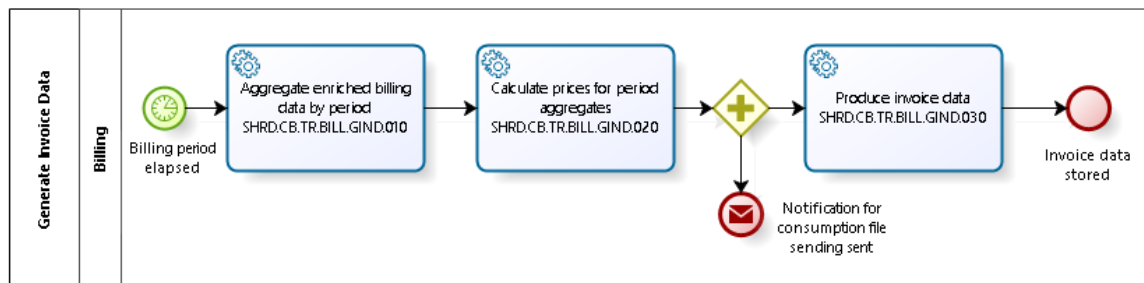

Business Process Model 2: Generate Invoice Data

1.3.2 Process Overview

Process goal:

This business process describes the generation of invoice data for the different settlement services, components and application common services.

Process context:

- ▶ The generic process and its descriptions are valid for all billing data for all services, components and applications.

Pre-conditions:

- ▶ The enriched aggregates from process "Aggregated Billing Data" (SHRD.BP.BILL.AGBD, see section 1.2 in this User Requirements Documents) are available for the full period.

Time constraints:

- ▶ None

Expected results:

- ▶ ~~The Billing service~~ will produce invoice data and store it afterwards.
- ▶ A notification for availability of the consumption file is sent to process "Send Consumption File" (SHRD.BP.BILL.SECF, see section 1.4 in this User Requirements Documents).

Triggers:

- ▶ The process will be initiated at the end of the billing period.

1.3.3 User Requirements

1.3.3.1 AGGREGATE ENRICHED BILLING DATA BY PERIOD

Task Ref: SHRD.CB.TR.BILL.GIND.010

Id	SHRD.CB.UR.BILL.GIND.010.010
Name	Aggregate by period: Trigger
Description	Billing shall aggregate by period at the end of the billing period. By default, the processing schedule is on a calendar month basis unless it is manually adjusted for a specific period by the service operator.

Id	SHRD.CB.UR.BILL.GIND.010.020
Name	Aggregation by period: Billing Period
Description	Billing shall aggregate all the charges within the billing period according to the defined levels of aggregation per Service, component and application .

Id	SHRD.CB.UR.BILL.GIND.010.030
Name	Billing period: Definition
Description	A billing period spans a full calendar month.

Id	SHRD.CB.UR.BILL.GIND.010.035
Name	Billing information availability
Description	<p>Billing shall allow a properly authorised user to query the billing information depending on</p> <ul style="list-style-type: none"> • Service/component/application; • System entity (Party to be billed); • Participant (Party to be billed); and • Period of time.

Id	SHRD.CB.UR.BILL.GIND.010.040
Name	Check for completeness of billing data
Description	Billing shall check the completeness of the stored enriched billing data. For instance, all daily aggregates have to be available for the aggregation by billing period.

1.3.3.2 CALCULATE PRICES FOR PERIOD AGGREGATES

Task Ref: SHRD.CB.TR.BILL.GIND.020

Id	SHRD.CB.UR.BILL.GIND.020.010
Name	Calculate aggregate prices
Description	Billing shall, for each relevant aggregate, assign a technical unit price per billable item, with precision of four digits after the decimal separator. The pricing policy determines which aggregate is relevant for each S service, <u>component or application</u> . The technical unit prices are derived from the service's pricing table.

Id	SHRD.CB.UR.BILL.GIND.020.020
Name	Pricing rules: Charge types
Description	<p>Billing shall differentiate between different charge types:</p> <ul style="list-style-type: none"> • Fixed charges to be billed ("standing charges"); • Variable charges from variable consumption ("call charges") - either with a constant factor or factors depending on the total volumes (e.g. with decreasing marginal prices, digressive prices, prices per volume batches); and • Special treatment rules (e.g. discounts, business groupings, Ancillary Systems Business, etc.). <p>For this differentiation, the Billing-service shall be supported by <u>Common Reference eData</u>.</p>

Id	SHRD.CB.UR.BILL.GIND.020.030
Name	Prices: Format
Description	Billing shall use prices which have to be established per S service, <u>component and application</u> and billable item in reference data. The prices shall have a precision of four digits after the decimal separator.

Id	SHRD.CB.UR.BILL.GIND.020.040
Name	Prices: Currency
Description	Prices are denominated in <u>euroEURO</u> .

Id	SHRD.CB.UR.BILL.GIND.020.050
Name	Pricing rules: Value added tax (VAT)
Description	<p>Billing shall derive the value added tax amounts to be paid based on the fee type, <u>Sservice, component and application</u> and system entity to which the Party to be charged is assigned to.</p> <p>Billing shall derive the appropriate VAT-rate(s) and VAT-number of the Party to be charged from the <u>Common rReference dData</u>.</p> <p>Each <u>Sservice, component and application</u> shall be able to define up to three (3) VAT rates.</p>

1.3.3.3 PRODUCE INVOICE DATA

Task Ref: SHRD.CB.TR.BILL.GIND.030

Id	SHRD.CB.UR.BILL.GIND.030.010
Name	Derivation rules: Party to be billed
Description	<p>Billing shall identify the recipient of invoice (Party to be billed) per <u>sService, component and application</u> and per Party to be charged based on the <u>Common rReference dData</u>, including for accounts closed during the month.</p>

Note: There has to be a contractual agreement in place between the Party to be charged and the Party to be billed.

Id	SHRD.CB.UR.BILL.GIND.030.020
Name	Derivation rules: Invoice due date
Description	<p>Billing shall derive the invoice due date based on the <u>Sservice, component and application</u> and <u>the</u> invoice creation date/issuance date.</p>

Id	SHRD.CB.UR.BILL.GIND.030.030
Name	Different billing addresses
Description	<p>Billing shall derive the billing address from the following attributes:</p> <ul style="list-style-type: none"> • Service/<u>component/application</u> • Participant (Party to be billed).

Note: As participants can request to have the invoice for each Sservice, component or application delivered to different in-house departments, different billing addresses (e.g., one per Sservice, component and application) have to be derived from the participant's Common rReference dData

(Party to be billed), for the aggregates for the various Services, component and applications. Common Reference Data shall allow associating one participant with multiple addresses for invoicing at the level of individual/group of Services, components and applications.

Id	SHRD.CB.UR.BILL.GIND.030.050
Name	Store Invoice Data
Description	<p>Billing shall store the invoice data created and shall track the status of the invoice data created. The status can be:</p> <ul style="list-style-type: none"> • Invoice Data Generated, but Invoice not Created; • Invoice Created, but not sent to the billing address; • Invoice Sent to the billing address, but Direct Debit not sent; • Invoice Sent to the billing address, and Direct Debit sent or not needed; or • Cancelled/Overwritten. <p>The status after the execution of this process will be "Invoice Data Generated but Invoice not Created".</p> <p>Billing shall assign a unique invoice ID to the invoices generated and stored.</p>

Id	SHRD.CB.UR.BILL.GIND.030.060
Name	Notify billing function on stored invoices
Description	<p>Billing shall notify the TARGET Service Desk upon status change of invoice data. The notification will thus be done:</p> <ul style="list-style-type: none"> • Once the billing/invoicing process (or a rerun) has been completed for a service <u>(component/application)</u>/system entity/participant; • Once the status of an already created invoice data has changed.

1.4 SEND CONSUMPTION FILE

Business Process Ref: SHRD.CB.BP.BILL.SECF

1.4.1 Business Process Model

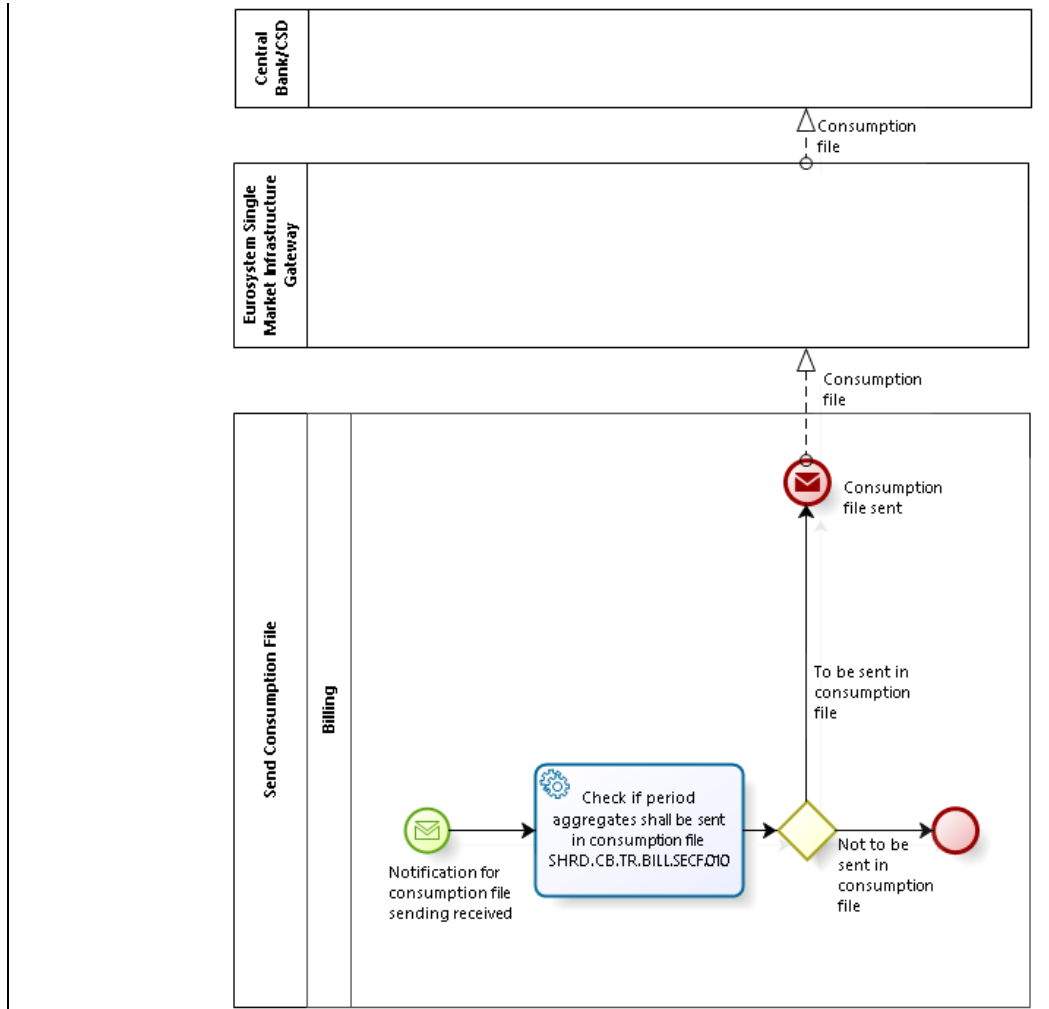

Business Process Model 3: Send Consumption File

1.4.2 Process Overview

Process goal:

This business process describes the sending of the consumption file. The system will give the possibility to automatically send consumption files to the system entities opting for their reception. The invoicing will then be processed locally by the system entity. Nonetheless, the respective consumption data is still fed into the central invoicing, even though the invoices will not be sent out.

If manual adjustments are input in the system, the consumption files shall be generated again and resent.

All invoicing data are available to authorised parties from a central location for further elaboration.

Process context:

- ▶ The generic process and its descriptions are valid for all invoices for all Sservices, components and applications.

Pre-conditions:

- ▶ The period aggregates from process “Generate Invoice Data” (SHRD.CB.BP.BILL.GIND, see section 1.3 in this User Requirements Document) are available for the specific sService (component/application)/system entity and billing period.

Time constraints:

- ▶ None

Expected results:

- ▶ ~~The Billing-service~~ will either send a consumption file to the specific system entity if specified so or
- ▶ Will do nothing.

Triggers:

- ▶ The process will be initiated by a notification for availability of the consumption file sent from process “Generate Invoice Data” (SHRD.CB.BP.BILL.GIND, see section 1.3 in this User Requirements Document).

1.4.3 User Requirements

1.4.3.1 CHECK IF PERIOD AGGREGATES SHALL BE SENT IN CCONSUMPTION FFILE

Task Ref: SHRD.CB.TR.BILL.SECF.010

Id	SHRD.CB.UR.BILL.SECF.010.010
Name	Push consumption file to authorised system entity
Description	<p>Billing shall push, if configured by the authorised system entities (CBs), the consumption files to the authorised system entities on a monthly basis. These consumption files can then be used as raw data for the system entities' internal billing processes.</p> <p>The ECB shall receive all consumption files for all <u>Sservices, components and applications</u>.</p>

Id	SHRD.CB.UR.BILL. SECF.010.020
Name	Consumption File: Content
Description	The consumption file shall contain the aggregated billing data. It must not contain the prices calculated for the aggregated billing data.

1.5 CORRECT INVOICE DATA MANUALLY

Business Process Ref: SHRD.CB.BP.BILL.MACO

1.5.1 Business Process Model

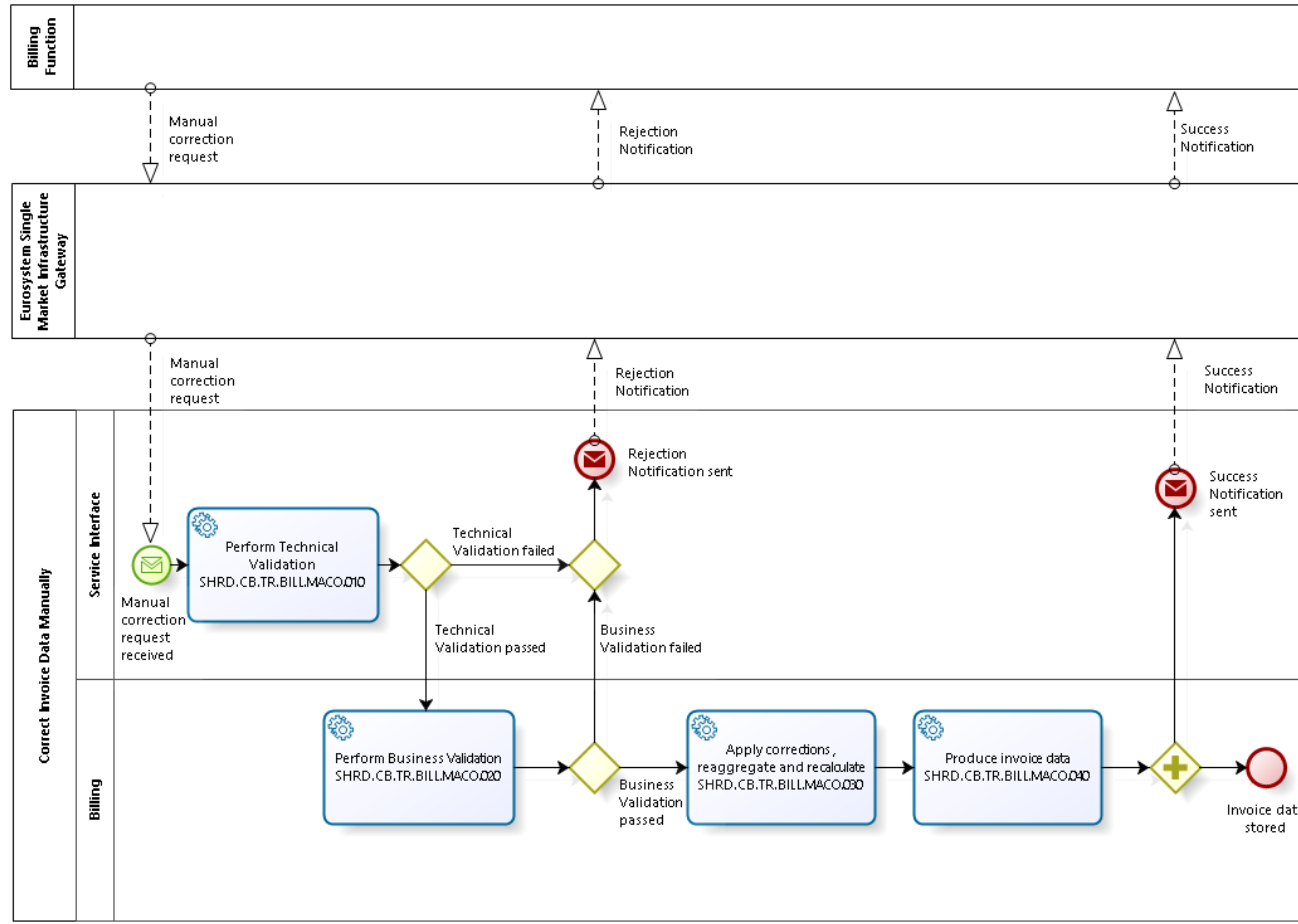

Business Process Model 4: Correct Invoice Data Manually

1.5.2 Process Overview

Process goal:

This business process describes the manual correction of an invoice. Upon ad-hoc request by the TARGET Service Desk, ~~the Billing-service~~ shall allow for manual corrections on invoices already created. Corrections on billable items will be handled in delta-mode. For instance, charges can only be reduced through entries with reverse charges and increased through additional entries with additional charges – no “direct manipulation” of original entries is allowed.

Process context:

- ▶ The generic process and its descriptions are valid for all invoices for all Ssservices, components and applications.

Pre-conditions:

- ▶ The stored invoice specified is available.

Time constraints:

- ▶ The process can only run within a given time frame for corrections (see SHRD.CB.UR.BILL.MACO.020.010 on corrections time frame).

Expected results:

- ▶ ~~The Billing-service~~ will either send a rejection notification with the appropriate error code(s) to the TARGET Service Desk or
- ▶ Will store the manually corrected invoice data and send a success notification to the TARGET Service Desk.

Triggers:

- ▶ The process will be initiated by a manual correction request from the TARGET Service Desk.

1.5.3 User Requirements

1.5.3.1 PERFORM TECHNICAL VALIDATION

Task Ref: **SHRD.CB.TR.BILL.MACO.010**

Id	SHRD.CB.UR.BILL.MACO.010.010
Name	Technical Validations
Description	<p>Billing will allow the TARGET Service Desk to request reruns or manual corrections of billing data. Billing shall ensure that the user input into the GUI is parsed and a field level validation is performed – e.g. on correct data type, size. Billing shall check if mandatory fields are populated.</p> <p>If the validation failed, Billing shall display error messages with appropriate reason codes on the screen of the requestor.</p>

1.5.3.2 PERFORM BUSINESS VALIDATION

Task Ref: **SHRD.CB.TR.BILL.MACO.020**

Id	SHRD.CB.UR.BILL.MACO.020.010
Name	Corrections time frame
Description	<p>Billing shall allow for manual corrections only within a given time frame after the creation of the invoice. The time frame depends on the sService (component/application)/system entity and billing period and can be configured as a system parameter per Sservice, component or application.</p>

1.5.3.3 APPLY CORRECTIONS, REAGGREGATE AND RECALCULATE

Task Ref: SHRD.CB.TR.BILL.MACO.030

Billing shall allow for manual interventions by the CB with regards to regular pricing corrections deviating from the normal pricing which have not been catered for in the automated steps.

Id	SHRD.CB.UR.BILL.MACO.030.010
Name	Manual corrections: "Special treatments"
Description	<p>Billing shall allow for manual corrections to apply discounts or "special treatments" at account/participant/Sservice <u>(component/application)</u>/system entity level and with relevant validity periods, in a form of</p> <ul style="list-style-type: none"> • an increase/decrease of a consumption per sService, <u>component or application</u>; • percentage increase/decrease of amount per account/participant; or • an addition of a fixed (flat) fee or minimum billed amount.

Note: This type of correction is purely of a manual nature, i.e. no further calculation steps by ~~the~~ Billing-~~service~~ are foreseen in that respect.

Id	SHRD.CB.UR.BILL.MACO.030.020
Name	Manual corrections: Other types of corrections
Description	<p>Corrections performed by the CB encompass inter alia the following "over-the-top" adjustments:</p> <ul style="list-style-type: none"> • Change of billing amount due date; and • Insert billable item aggregate into the invoice

Id	SHRD.CB.UR.BILL.MACO.030.030
Name	Manual corrections: additional billable items
Description	<p>Corrections performed by the CB encompass inter alia the following "over-the-top" adjustments performed in A2A or U2A modes:</p> <ul style="list-style-type: none"> • Insert additional billable item aggregate into the invoice

1.5.3.4 PRODUCE ~~I~~INVOICE ~~D~~DATA

Task Ref: SHRD.CB.TR.BILL.MACO.040

In addition to the requirements in SHRD.CB.TR.BILL.CRIN.030 [on producing of invoices \(see section 1.7.3.3 in this User Requirements Document\)](#), the following applies:

Id	SHRD.CB.UR.BILL.MACO.040.010
Name	Invoice data status change
Description	<p>Billing shall store the invoice data created after manual correction and shall change the status of the invoice data created previously. The initial status (before the changes) may be:</p> <ul style="list-style-type: none">• Invoice Data Generated, but Invoice not Created;• Invoice Created, but not sent to the billing address;• Invoice Sent to the billing address, but Direct Debit not sent;• Invoice Sent to the billing address, and Direct Debit sent or not needed; or• Cancelled/Overwritten; <p>The status after the execution of this process will be "Invoice Data Generated but Invoice not Created".</p>

1.6 REGENERATE INVOICE DATA

Business Process Ref: SHRD.CB.BP.BILL.REIN

1.6.1 Business Process Model

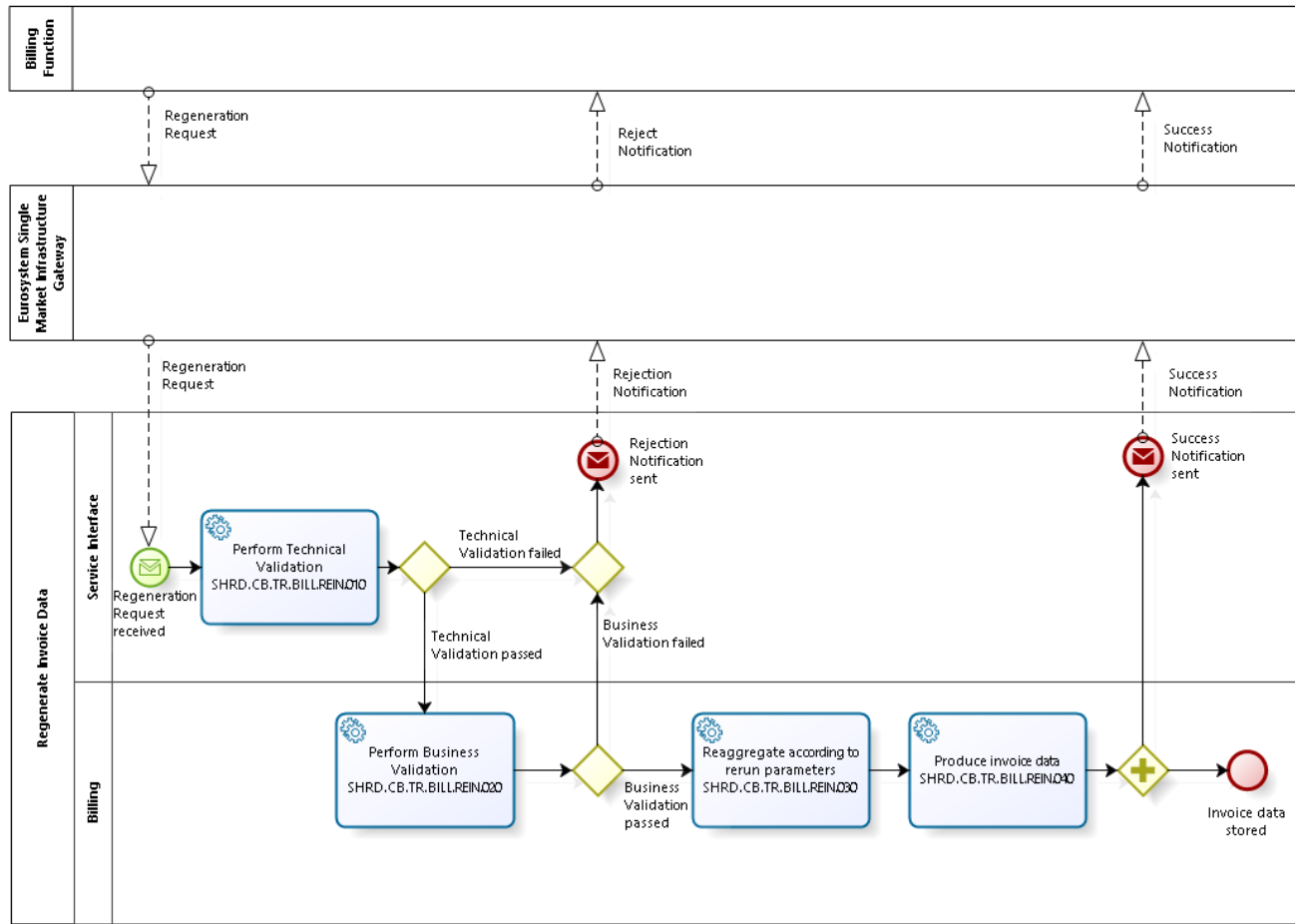

Business Process Model 5: Regenerate Invoice Data

1.6.2 Process Overview

Process goal:

This business process describes the regeneration of invoices. ~~The Billing-service~~ shall allow the TARGET Service Desk to request ~~at~~ cancellation and regenerate ion of an invoice. The response to that request will be provided as a new invoice, provided that internal investigations of competent parties lead to activation of the re-run action in the system, or other manual forms of feedback.

Note: if a direct debit is involved, the regeneration made after a payment is settled shall also issue a reverse payment order to cancel the initial payment.

Process context:

- ▶ The generic process and its descriptions are valid for all invoices for all Services, components and applications.

Pre-conditions:

- ▶ The stored invoices from process "Create Invoice" (SHRD.CB.BP.BILL.CRIN, see section 1.7 in this User Requirements Document),/ process "Correct Invoice Data Manually" (SHRD.CB.BP.BILL.MACO, see section 1.5 in this User Requirements Document)/ or from process "Regenerate Invoice Data" (SHRD.CB.BP.BILL.REIN, this section) are available for the specified rerun parameters.

Time constraints:

- ▶ None.

Expected results:

- ▶ ~~The Billing-service~~ will either send a rejection notification with the appropriate error code(s) to the TARGET Service Desk or
- ▶ Will store the regenerated invoice data and send a success notification.

Triggers:

- ▶ The process will be initiated by a regeneration request from the TARGET Service Desk.

1.6.3 User Requirements

1.6.3.1 PERFORM TECHNICAL VALIDATION

Task Ref: **SHRD.CB.TR.BILL.REIN.010**

Same as SHRD.CB.TR.BILL.MACO.010 (Perform Technical Validation).

1.6.3.2 PERFORM BUSINESS VALIDATION

Task Ref: SHRD.CB.TR.BILL.REIN.020

Id	SHRD.CB.UR.BILL.REIN.020.010
Name	Regenerate invoice: Trigger through rerun request
Description	Billing shall allow properly authorised users to manually trigger a rerun of the billing process.

Id	SHRD.CB.UR.BILL.REIN.020.020
Name	Regenerate Invoice: Rerun parameters
Description	<p>Billing shall rerun the billing process according to rerun parameters given by the user. The parameters can be:</p> <ul style="list-style-type: none"> • Party to be charged; • Party to be billed; • Account; • Service/<u>component/application</u>; • System entity; • Billing period; and • National community <p>By default, if no parameter has been given, the whole billing process as described in <u>process "Create Invoice" (SHRD.CB.BP.BILL.CRIN, see section 1.7 in this User Requirements Document)</u> is rerun.</p>

1.6.3.3 REAGGREGATE ACCORDING TO RERUN PARAMETERS

Task Ref: SHRD.CB.TR.BILL.REIN.030

Same as SHRD.CB.TR.BILL.GIND.010 (Aggregate enriched billing data by period) and SHRD.CB.TR.BILL.GIND.020 (Calculate prices for period aggregates), where the perimeter of reaggregation is given by the rerun parameters from SHRD.CB.UR.BILL.REIN.020.020 (Regenerate Invoice: Rerun parameters).

1.6.3.4 PRODUCE ~~I~~INVOICE ~~D~~DATA

Task Ref: SHRD.CB.TR.BILL.REIN.040

Same as SHRD.CB.TR.BILL.MACO.040 (Produce invoice data).

1.7 CREATE INVOICE

Business Process Ref: SHRD.CB.BP.BILL.CRIN

1.7.1 Business Process Model

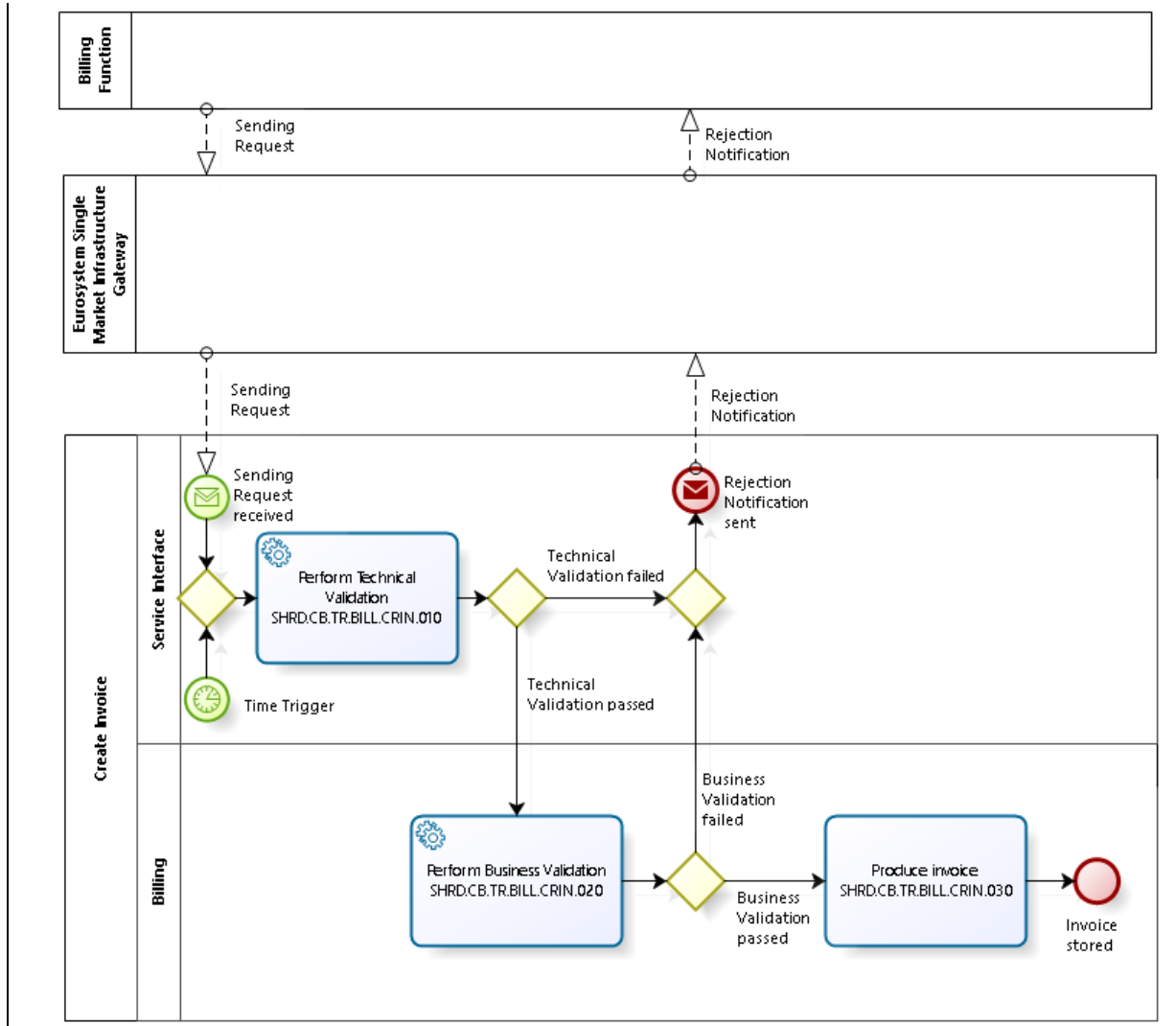

Business Process Model 6: Create Invoice

1.7.2 Process Overview

Process goal:

This business process describes the creation of invoices for the different settlement services, [components](#) and [applicationsecommon services](#).

Process context:

- The generic process and its descriptions are valid for all invoice data for all [sServices](#), [components and applications](#).

Pre-conditions:

- ▶ The invoice data from [process “Generate Invoice Data” \(SHRD.CB.BP.BILL.GIND, see section 1.3 in this User Requirements Document\)](#), [process “Correct Invoice Data Manually” \(SHRD.CB.BP.BILL./MACO, see section 1.5 in this User Requirements Document\)](#) or from [process “Regenerate Invoice Data” \(SHRD.CB.BP.BILL./REIN, see section 1.6 in this User Requirements Document\)](#) are available for the full period.

Time constraints:

- ▶ None

Expected results:

- ▶ ~~The Billing-service~~ will create an invoice and store it afterwards.

Triggers:

- ▶ The process will be initiated either by a request sent by the TARGET Service Desk or
- ▶ An automated time trigger after a pre-defined period of time.

1.7.3 User Requirements

1.7.3.1 PERFORM TECHNICAL VALIDATION

Task Ref: SHRD.CB.TR.BILL.CRIN.010

Id	SHRD.CB.UR.BILL.CRIN.010.010
Name	Technical Validations
Description	<p>Billing will allow the TARGET Service Desk to request the creation of invoices. Billing shall ensure that the user input into the GUI is parsed and a field level validation is performed – e.g. on correct data type, size. Billing shall check if mandatory fields are populated.</p> <p>If the validation failed, the Billing-service shall display error messages with appropriate reason codes on the screen of the requestor.</p>

1.7.3.2 PERFORM BUSINESS VALIDATION

Task Ref: SHRD.CB.TR.BILL.CRIN.020

Id	SHRD.CB.UR.BILL.CRIN.020.010
Name	Invoice creation time frame
Description	<p>Billing shall allow for creation of invoices only within a given time frame after the creation of the invoice data. The time frame depends on the Sservice (component/application)/system entity and the billing period and can be</p>

configured as a system parameter per [Service, component and application](#).

1.7.3.3 PRODUCE ~~I~~INVOICE

Task Ref: **SHRD.CB.TR.BILL.CRIN.030**

Id	SHRD.CB.UR.BILL.CRIN.030.010
Name	Derivation rules: Party to be billed
Description	Billing shall identify the recipient of invoice (Party to be billed) per Service, component or application and per Party to be charged based on the Common Reference Data.

Note: There has to be a contractual agreement in place between the Party to be charged and the Party to be billed.

Id	SHRD.CB.UR.BILL.CRIN.030.020
Name	Derivation rules: Invoice due date
Description	Billing shall derive the invoice due date based on the Service, component or application and the invoice creation date/issuance date.

Id	SHRD.CB.UR.BILL.CRIN.030.030
Name	Different billing addresses
Description	Billing shall derive the billing address from the following attributes: <ul style="list-style-type: none"> • Service/component/application • Participant (Party to be billed).

Note: As participants can request to have the invoice for each [Service, component or application](#) delivered to different in-house departments, different billing addresses (e.g., one per [Service, component and application](#)) have to be derived from the participant's [Common Reference Data](#) (Party to be billed), for the aggregates for the various [Services, components and applications](#). [Common Reference Data](#) allow associating one participant with multiple addresses for invoicing at the level of individual/group of [Services, components and applications](#).

Id	SHRD.CB.UR.BILL.CRIN.030.040
Name	Invoice format
Description	Billing shall ensure that: <p>The aggregates from aggregation calculated are used to produce an invoice;</p> <ul style="list-style-type: none"> • At the level of the total billed amount per Party, the aggregated charges

	<p>(high-precision decimals) are rounded to two digits;</p> <ul style="list-style-type: none"> • The invoices are in either XML or pdf format or both, according to the billing address; • There shall be no item with zero amounts appearing in the invoice; and • Invoices formats and layout can be customized by CBs (e.g., different logos/headers/footers).
--	--

Id	SHRD.CB.UR.BILL.CRIN.030.045
Name	Multiple templates
Description	<p>Billing shall provide multiple templates for creating the invoices, fully customisable by CB, layout and components.</p> <p>Templates can be different per <u>sService, component and application</u>, including dedicated templates for additional (national) billable items.</p>

Id	SHRD.CB.UR.BILL.CRIN.030.050
Name	Store Invoices
Description	<p>Billing shall store the invoices created and shall track the status of the invoices created. The status can be:</p> <ul style="list-style-type: none"> • Invoice Data Generated, but Invoice not Created; • Invoice Created, but not sent to the billing address; • Invoice Sent to the billing address, but Direct Debit not sent; • Invoice Sent to the billing address, and Direct Debit sent or not needed; or • Cancelled/Overwritten; <p>Billing shall assign a unique invoice ID to the invoices generated and stored. The status after the execution of this process will be " Invoice Created, but not sent to the billing address ".</p> <p>Note: the list of status will be further refined during the realisation phase.</p>

Id	SHRD.CB.UR.BILL.CRIN.030.060
Name	Status of stored invoices
Description	<p>Billing shall store and display status changes of invoices. The notification will thus be done:</p> <ul style="list-style-type: none"> • Once the billing/invoicing process (or a rerun) has been completed for a Service/system entity/participant;

- Once the status of an already created invoice has changed.

1.8 SEND INVOICE

Business Process Ref: SHRD.CB.BP.BILL.SEIN

1.8.1 Business Process Model

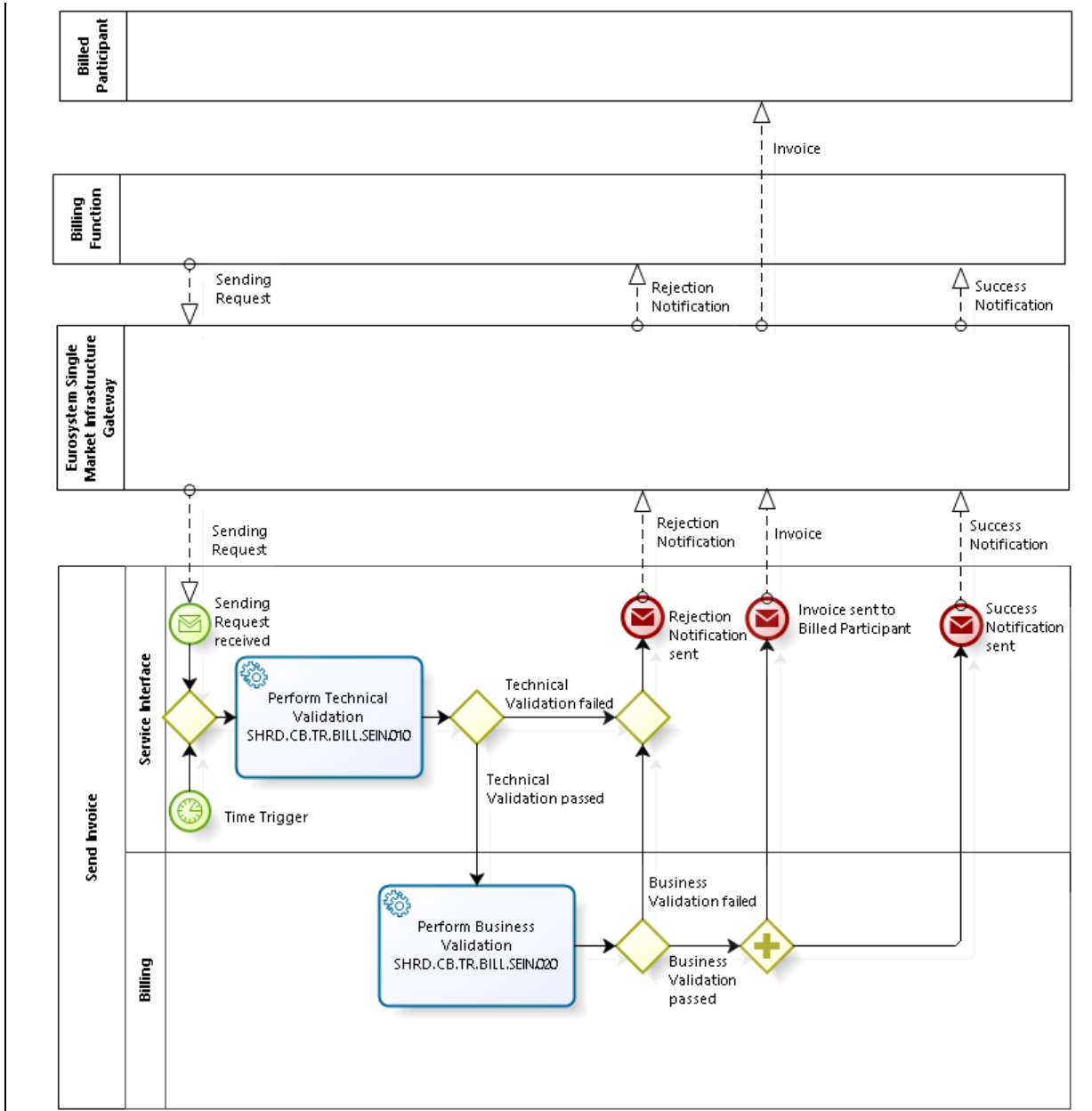

Business Process Model 7: Send Invoice

1.8.2 Process Overview

Process goal:

This business process describes the sending of an invoice. Upon manual request by the TARGET Service Desk or an automated trigger, ~~the Billing service~~ shall send an invoice created.

Process context:

- ▶ The generic process and its descriptions are valid for all invoices for all Services, components and applications.

Pre-conditions:

- ▶ The stored invoices from process "Create Invoice" (SHRD.CB.BP.BILL.CRIN, see section 1.7 in this User Requirements Document) are available for the specific Service (component/application)/system entity and the billing period and in a proper status.

Time constraints:

- ▶ None

Expected results:

- ▶ ~~The Billing service~~ will either send, optionally, a rejection notification with the appropriate error code(s) to the TARGET Service Desk or
- ▶ Will send the invoice and, optionally, a success notification to the TARGET Service Desk.

Triggers:

- ▶ The process will be initiated either by a request sent by the TARGET Service Desk or
- ▶ An automated time trigger after a pre-defined period of time.

1.8.3 User Requirements

1.8.3.1 PERFORM TECHNICAL VALIDATION

Task Ref: SHRD.CB.TR.BILL.SEIN.010

Same as SHRD.CB.TR.BILL.MACO.010 (Perform Technical Validation).

1.8.3.2 PERFORM BUSINESS VALIDATION

Task Ref: SHRD.CB.TR.BILL.SEIN.020

Id	SHRD.CB.UR.BILL.SEIN.020.010
Name	Send invoice: Manual trigger
Description	Billing shall allow the TARGET Service Desk to request sending of an invoice already created.

Id	SHRD.CB.UR.BILL.SEIN.020.020
Name	Send Invoice: Automatic Trigger
Description	<p>Billing shall automatically trigger the sending of an invoice, either individually or in batches, after a predefined period of time depending on:</p> <ul style="list-style-type: none"> • Billing period; • Billed Sservice, <u>component and application</u>; and • System entity <p>Authorised users shall be able to de-activate the automatic sending for specific sServices, <u>components or applications</u>, system entities, or participants, for specific billing periods.</p>

Id	SHRD.CB.UR.BILL.SEIN.020.030
Name	Business Validation: invoice sending parameters
Description	<p>Billing shall validate the following invoice sending parameters given in the sending request:</p> <ul style="list-style-type: none"> • Billing period; • Billed sService/<u>component/application</u>; • Billed Party; • System entity; and • Invoice status <p>If the respective CB has opted for invoicing through its local applications and therefore no invoice shall be sent from the Billing-service, the business validation fails and the process stops and, optionally, provides appropriate messages.</p>

Id	SHRD.CB.UR.BILL.SEIN.020.040
Name	Business Validation: invoice status
Description	<p>Billing shall send the latest created invoice (i.e. with status “Invoice created, but not sent to the billing address”) for the given sending parameters upon positive business validation and shall change the status of the invoice.</p> <p>The status after the execution of this process will be "Invoice Sent to the billing address, but Direct Debit not sent" or "Invoice Sent to the billing address, and Direct Debit sent or not needed", depending on the need to issue a direct debit for the related it invoice;</p> <p>If there is no latest created invoice (i.e. with status “Invoice created, but not sent to the billing address”), the business validation fails and the process stops and, optionally, provides appropriate rejection notifications <u>with the appropriate error code(s)</u>.</p>

Id	SHRD.CB.UR.BILL.SEIN.020.045
Name	Routing of the invoices
Description	<p>Billing shall send the invoices either to the participants, or to the CB that will then route them to their participants, according to a parameter set in CRDM for each CB.</p>

Id	SHRD.CB.UR.BILL.SEIN.020.050
Name	Copy to CBs and ECB
Description	<p>Billing shall send or allow retrieving the copy of the invoices and underlying files or data to the respective CB and the ECB (for the whole system) automatically and in parallel to the respective billed Party for selected S <u>services, components or applications</u>.</p>

1.9 CANCEL INVOICE

Business Process Ref: SHRD.CB.BP.BILL.CAIN

1.9.1 Business Process Model

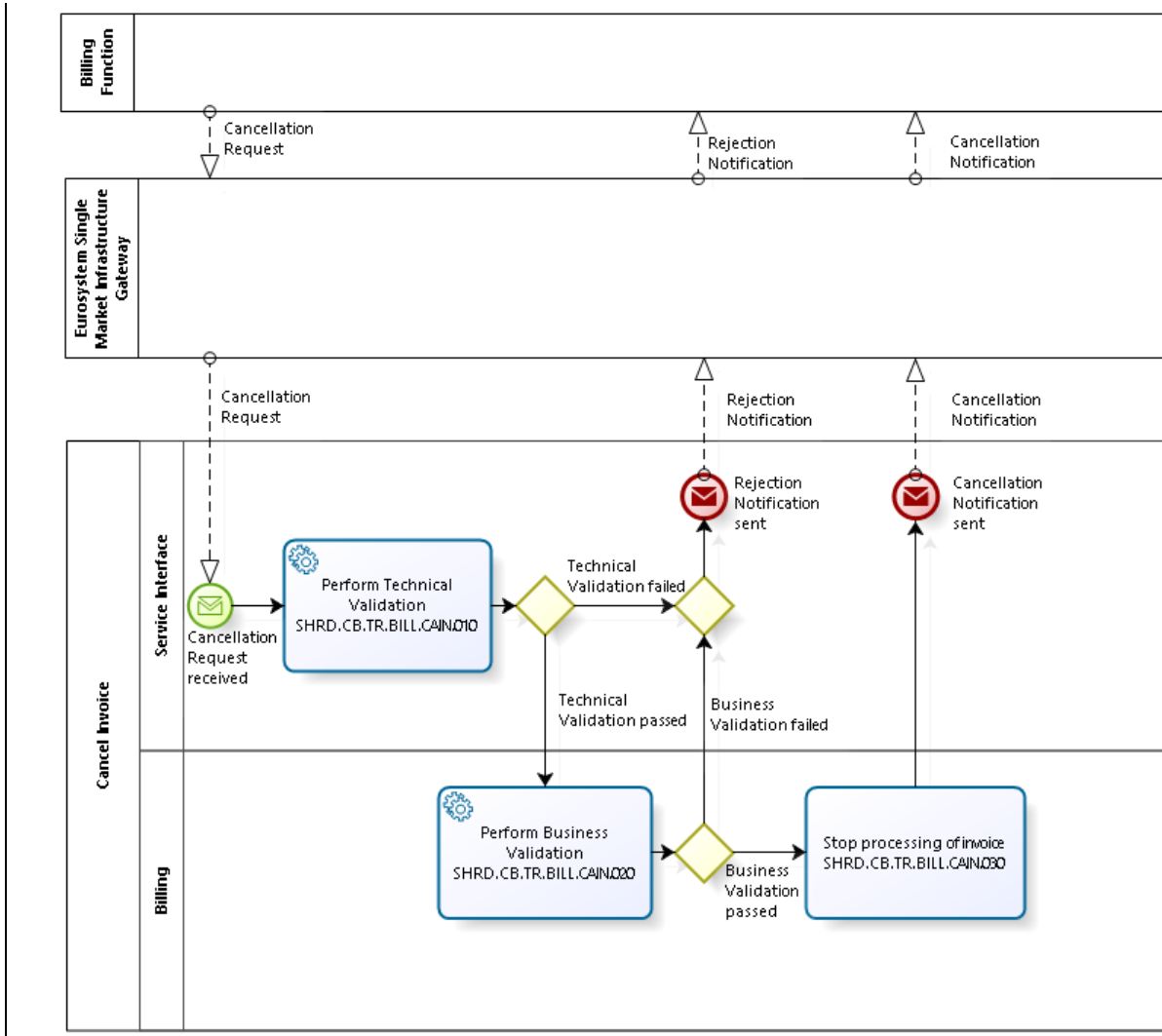

Business Process Model 8: Cancel Invoice

1.9.2 Process Overview

Process goal:

This business process describes the cancellation of the automated sending of an invoice. Upon manual request by the TARGET Service Desk, ~~the Billing service~~ shall cancel the automated sending of an invoice created. For the Parties with a direct debit option, the pre-specified MCAs will not be debited for the amounts reported in invoices for which the status is changed to "cancelled".

Note: For the cash settlement services, components and applications~~shared-services~~ (i.e. not securities settlement services), where an invoice already sent out is legitimately disputed by a customer, the CB can manually create and issue:

- ▶ A reverse invoice and, optionally;
- ▶ A reverse payment order to cancel the initial payment; and
- ▶ A new payment order with the new amount and its direct debit message to the customer

Process context:

- ▶ The generic process and its descriptions are valid for all invoices for all sServices, components and applications.

Pre-conditions:

- ▶ The invoice specified is available and in a proper status.

Time constraints:

- ▶ None

Expected results:

- ▶ ~~The Billing-service~~ will either send a rejection notification with the appropriate error code(s) to the TARGET Service Desk or
- ▶ Will cancel the invoice and send a cancellation notification to the ~~central~~ TARGET Service Desk.

Triggers:

- ▶ The process will be initiated by a cancellation request from the TARGET Service Desk.

1.9.3 User Requirements

1.9.3.1 PERFORM TECHNICAL VALIDATION

Task Ref: SHRD.CB.TR.BILL.CAIN.010

Same as SHRD.CB.TR.BILL.MACO.010 (Perform Technical Validation).

1.9.3.2 PERFORM ~~B~~BUSINESS ~~V~~VALIDATION

Task Ref: SHRD.CB.TR.BILL.CAIN.020

Id	SHRD.CB.UR.BILL.CAIN.020.010
Name	Cancel invoice: Manual trigger
Description	Billing shall allow the TARGET Service Desk to request the cancellation of an invoice already created.

Id	SHRD.CB.UR.BILL.CAIN.020.020
Name	Business validation: invoice cancel parameters
Description	<p>Billing shall validate the following invoice cancel parameters given in the cancellation request:</p> <ul style="list-style-type: none"> • Billing period; • Billed sService/component/application; • Billed Party; and • System entity

Id	SHRD.CB.UR.BILL.CAIN.020.030
Name	Business validation: invoice status
Description	<p>Billing shall check for the availability of the invoice to be cancelled. The invoice status must be:</p> <ul style="list-style-type: none"> • Invoice Created, but not sent to the billing address yet; • Invoice Sent to the billing address-, but Direct Debit not sent; or • Invoice Sent to the billing address, and Direct Debit sent or not needed; or • If not any of the above, Billing shall reject the request <u>and display the appropriate error message</u>.

1.9.3.3 STOP PROCESSING OF INVOICE

Task Ref: SHRD.CB.TR.BILL.CAIN.030

Id	SHRD.CB.UR.BILL.CAIN.030.010
Name	Stop sending <u>of invoice</u> and debiting
Description	Upon authorised and valid request, Billing shall cancel the process of sending invoice and optionally the direct debiting for the given parameters.

Note: It is up to the system entity to set up a business process with their participants on how to deal with cancellation (amendment) of invoices after they have already been sent out.

1.10 DIRECT DEBIT

Business Process Ref: SHRD.CB.BP.BILL.SEDD

1.10.1 Business Process Model

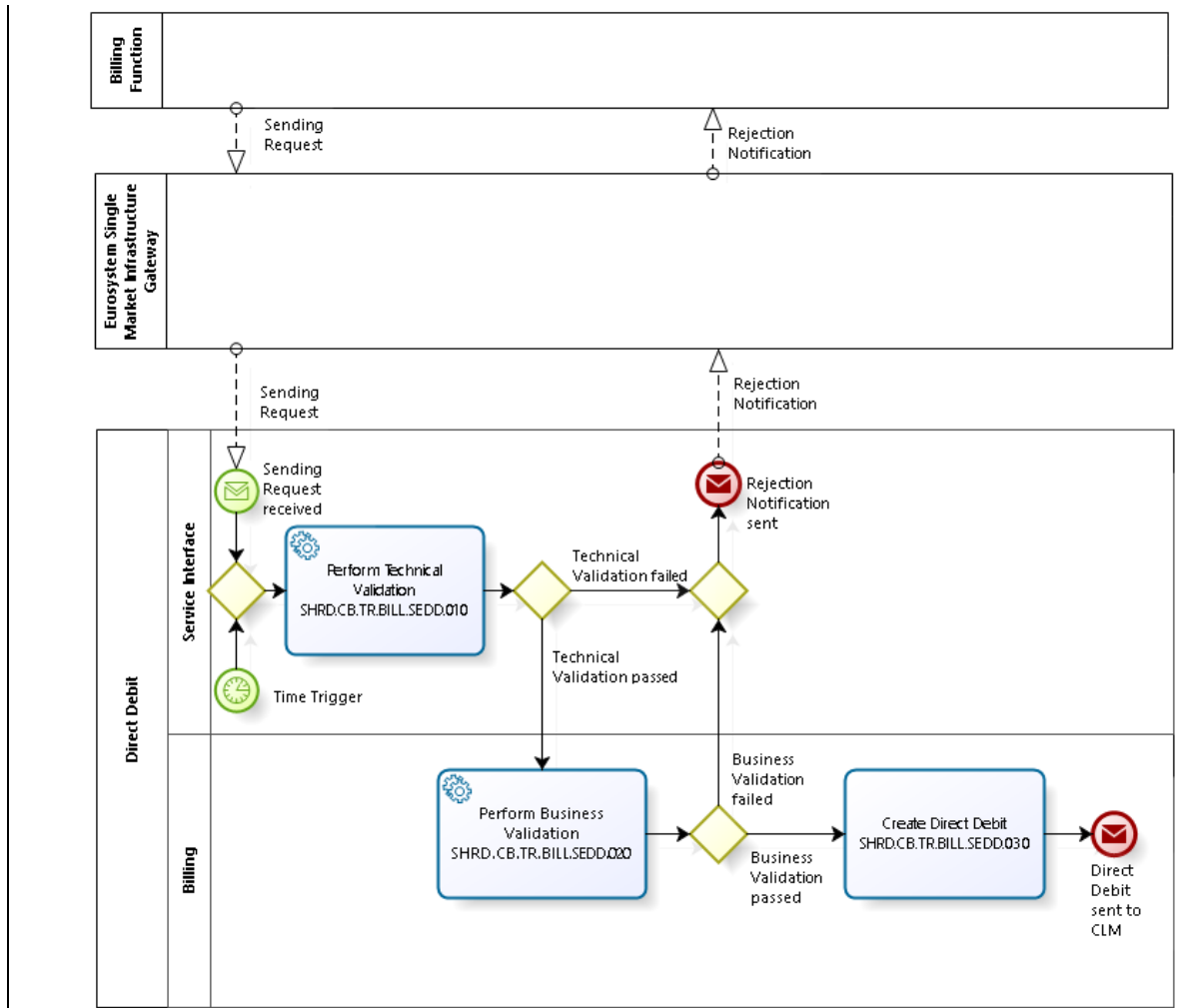

Business Process Model 9: Direct Debit

1.10.2 Process Overview

Process goal:

This business process describes the sending of a direct debit. Upon manual request by the TARGET Service Desk or an automated trigger, ~~the Billing service~~ shall optionally send a direct debit for the Parties ~~with a direct debit option~~: the pre-specified MCAs will be debited according to the invoices sent out.

Process context:

- ▶ The generic process and its descriptions are valid for all invoices for all Sservices, components and applications.

Pre-conditions:

- ▶ The stored invoices from [process "Create Invoice" \(SHRD.CB.BP.BILL.CRIN, see section 1.7 in this User Requirements Document\)](#) are available and sent for the specific [Service \(component/application\)/system entity](#) and [the](#) billing period and in a proper status.

Time constraints:

- ▶ None

Expected results:

- ▶ ~~The Billing service~~ will either send, optionally, a rejection notification [with the appropriate error code\(s\)](#) to the TARGET Service Desk or
- ▶ Will send the direct debit and, optionally, a success notification to the TARGET Service Desk.

Triggers:

- ▶ The process will be initiated either by a request sent by the TARGET Service Desk or
- ▶ An automated time trigger after a pre-defined period of time.

1.10.3 User Requirements

1.10.3.1 PERFORM TECHNICAL VALIDATION

Task Ref: SHRD.CB.TR.BILL.SEED.010

Same as [SHRD.CB.TR.BILL.MACO.010 \(Perform Technical Validation\)](#)~~SHRD.CB.TR.BILL.SEIN.010.~~

1.10.3.2 PERFORM BUSINESS VALIDATION

Task Ref: SHRD.CB.TR.BILL.SEED.020

Id	SHRD.CB.UR.BILL.SEED.020.010
Name	Direct Debit: Manual trigger
Description	Billing shall allow the TARGET Service Desk to request sending of a direct debit.

Id	SHRD.CB.UR.BILL.SEED.020.020
Name	Direct Debit: Automatic Trigger
Description	Billing shall automatically trigger the sending of a direct debit, either individually or in batches, after a predefined period of time depending on: <ul style="list-style-type: none"> • Billing period; • Billed Service (component/application); and • System entity

	<p>Authorised users shall be able to de-activate the automatic sending for specific <u>Sservices, components or applications</u>, system entities, or participants, for specific billing periods.</p>
--	---

Id	SHRD.CB.UR.BILL.SEDD.020.030
Name	Business Validation: Direct Debit sending parameters
Description	<p>Billing shall validate the following direct debit sending parameters given in the sending request:</p> <ul style="list-style-type: none"> • Billing period; • Billed <u>Sservice/component/application</u>; • Billed Party; • System entity; and • Invoice status <p>If the respective CB has not opted for the sending of direct debits, and therefore no direct debit shall be sent from the Billing-service, the business validation fails and the process stops and, optionally, provides <u>appropriate rejection notification with the appropriate error code(s)</u>.</p>

Id	SHRD.CB.UR.BILL.SEDD.020.040
Name	Business Validation: Direct Debit status
Description	<p>Billing shall send the direct debit for the sent hinvoice (i.e. with status "Invoice Sent to the billing address, but Direct Debit not sent") for the given sending parameters upon positive business validation and shall change the status of the invoice.</p> <p>The status after the execution of this process will be "Invoice Sent to the billing address and Direct Debit sent or not needed".</p> <p>If there is no latest sent invoice (i.e. with status "Invoice Sent to the billing address, but Direct Debit not sent"), the business validation fails and the process stops and, optionally, provides appropriate-rejection notifications <u>with the appropriate error code(s)</u>.</p>

1.10.3.3 CREATE DIRECT DEBIT

Task Ref: SHRD.CB.TR.BILL.SEED.030

Id	SHRD.CB.UR.BILL.SEED.030.010
Name	Create direct debits
Description	<p>If chosen in the setup of the billed participant's reference data, Billing shall create a direct debit to debit the pre-defined account for debits and credit the pre-defined account for credits.</p> <p>The account to be debited shall be an MCA belonging to the debited participant and denominated in <u>euroEURO</u>.</p> <p>For internal bookkeeping purposes and in order to enable system entities to differentiate revenues for administrative purposes, Billing shall assign an invoice reference to the direct debit.</p>

Note: Only MCAs denominated in euroEURO can be debited by a direct_-debit. E.g. a TIPS participant not having a MCA account in euroEURO, would have to ensure that a payment can be made through a CLM account holder with an euroEURO-MCA-holder the TIPS participant has a contractual arrangement with.

Id	SHRD.CB.UR.BILL.SEED.030.020
Name	Different accounts
Description	<p>Billing shall be able to send direct debits linked to invoices per <u>Sservice, component or application</u> to different accounts, which shall be configured in the participant's <u>Common Reference Data</u> and could be different from the participant's account being billed.</p>

Id	SHRD.CB.UR.BILL.SEED.030.030
Name	Account to be credited
Description	<p>The account to be credited is a mandatory field when setting up the direct debits. The account to be credited shall be set up for each <u>sService, component and application</u>, for all participants by each CB or by the ECB depending on the policy applicable to the <u>Sservice, component and application</u>.</p>

1.11 BILLING GATHER INFORMATION

Business Process Ref: SHRD.CB.BP.BILL.GATH

1.11.1 Business Process Model

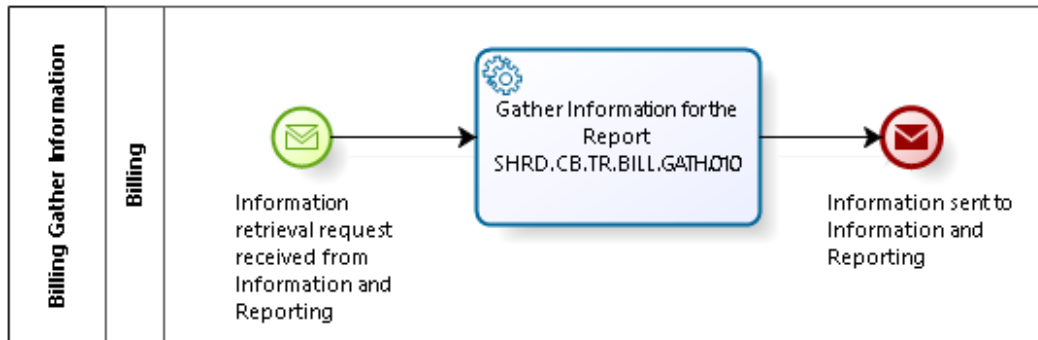

Business Process Model 10: Billing Gather Information

1.11.2 Process Information

Process goal:

- ▶ This process describes the provision of information to Information and Reporting. Data will be stored in ~~the~~Data Warehouse, and as any query in ~~the~~DWH, information can be downloaded (see section 6 on Data Warehouse ~~Service~~ in the User Requirements Document for Common Components~~Shared Services~~).

Process context:

- ▶ The generic process and its descriptions are valid for all information in ~~the~~Billing ~~service~~.

Pre-conditions:

- ▶ The information requested is available to ~~the~~Billing ~~service~~.

Time constraints:

- ▶ None

Expected results:

- ▶ ~~The~~Billing ~~service~~ sent the requested information to Information and Reporting ~~Services~~.

Triggers:

- ▶ This process is triggered through an information retrieval request from Information and Reporting.

1.11.3 User Requirements

1.11.3.1 GATHER INFORMATION FOR THE REPORT

Task Ref: **SHRD.CB.TR.BILL.GATH.010**

Id	SHRD.CB.UR.BILL.GATH.010.000
Name	Retrievability of consumption data
Description	<p>Consumption data and participation/reference data shall be retrievable per originator and per billed Party as well as per system entity of the billed Party (CB or CSD) for each <u>Sservice, component and application</u>.</p> <p>A system entity (CB or CSD) shall have read access to the billing/invoicing information collected for their billed participants, including those charges generated by other participants allocated to other system entities (cross border links, branches, etc.) billed through its billed participants. The ECB shall have access to billing/invoicing data across the system for all participants/system entities.</p>

Note: In the case of cross-border aggregation of charges, some CBs could have read access to some billing data of participants allocated to other CBs.

Id	SHRD.CB.UR.BILL.GATH.010.010
Name	Reporting on Billing: Monitoring the invoicing activity
Description	<p>The services shall provide data to cater for reporting:</p> <ul style="list-style-type: none"> • On <u>i</u>nvoicing activity (total volumes/total counts); • Per system entity; • Per participant; • Per Ancillary System; • Per <u>Sservice/component/application</u>; • Per billing period; and • Per invoice type. <p>Only authorised Central Banks have read access to the report.</p>

Id	SHRD.CB.UR.BILL.GATH.010.020
Name	Reporting on Billing: Audit of critical data for a given period
Description	<p>The Services shall provide data to cater for reporting:</p> <ul style="list-style-type: none">• On modifications of critical data;• For a given period;• Per national banking community;• Per participant;• Per Ancillary System; and• Per Distinguished Name. <p>Only authorised Central Banks have read access to the report.</p>

Id	SHRD.CB.UR.BILL.GATH.010.030
Name	Reporting on Billing: Copy of an Invoice
Description	<p>If the system produces invoices, Billing shall provide copies of invoices:</p> <ul style="list-style-type: none">• Per participant;• Per Ancillary System; and• Per national banking community. <p>Only authorised Central Banks have read access to the report.</p>

Id	SHRD.CB.UR.BILL.GATH.010.040
Name	Reporting on Billing: Revenues reporting
Description	<p>Billing shall provide data to cater for reporting:</p> <ul style="list-style-type: none"> • On pooling of revenues and redistribution of revenues; • Per <u>Sservice/component/application</u>; • Per pricing type: <ul style="list-style-type: none"> - Core pricing; - Fee for the optional “T2S value added services“; - Fee per Dedicated Cash Account; - Ancillary System pricing; or - Liquidity pooling. • Per nature of the fees: <ul style="list-style-type: none"> - Fixed fees; or - Transactions fees • Per type of participation: <ul style="list-style-type: none"> - Indirect participation; - Multi-addressee access; - etc. • Per period given; and • Per participant <p>Only authorised Central Banks have read access to the report.</p>

Note: By the reporting means described above, the Central Banks can, for internal bookkeeping and administrative purposes, differentiate their revenues.

Id	SHRD.CB.UR.BILL.GATH.010.050
Name	Reporting on Billing: Detailed consumption
Description	<p>Billing shall provide data to cater for reporting:</p> <ul style="list-style-type: none"> • On consumption; • Per <u>Sservice/component/application</u>; • Per period given; • Per Ancillary System; • Per participant; • Per flow type; and • Per account. <p>Only authorised Central Banks have read access to the report.</p>

Id	SHRD.CB.UR.BILL.GATH.010.060
Name	Reporting on Billing: Detailed participation
Description	<p>Billing shall provide data to cater for reporting:</p> <ul style="list-style-type: none">• On participation;• Per sService/component/application;• Per period given; and• Per participant <p>Only authorised Central Banks have read access to the report.</p>

1.12 BILLING – NON-FUNCTIONAL REQUIREMENTS

1.12.1 Availability

Id	SHRD.CB.UR.BILL.NFR.020
Name	Availability
Description	Availability of Billing measured on a quarterly basis shall be at least 95%.

1.12.2 Disaster Recovery

Id	SHRD.CB.UR.BILL.NFR.030
Name	Recovery Time Objective
Description	Billing shall ensure a recovery time objective value of three days.

The recovery time objective (RTO) is the maximum amount of time required for recovery or restart of the sService to a specified point of consistency. Billing shall be restored within three days after the decision to restart the componentService.

1.12.3 Performance Requirements

Id	SHRD.CB.UR.BILL.NFR.040
Name	Maximum Batch Processing Time
Description	Billing shall process the billing files in maximum one day. This applies for possible reruns as well.

The processing of the data relevant for Billing shall not exceed one day. Should a rerun of billing data be necessary the one day limit applies as well.

2 LEGAL ARCHIVING (LAR)

2.1 OVERVIEW

The **componentService** for legal archiving collects all information which is subject to legal archiving requirements. This comprises currently all incoming and outgoing business transactions from and to Parties as well as relevant reports such as account statements. The information has to be stored in its original content and format and has to be accessible within its retention period. The means to access the data have to be in place while the data is retained.

If possible, a single solution for legal archiving and Data Warehouse **services** shall be used to reduce development and operating costs. If a solution is found in **the** Data Warehouse to store and seal data subject to legal archiving in its original format and in a way future manipulation is prevented no separate solution has to be built.

2.1.1 Context Diagram

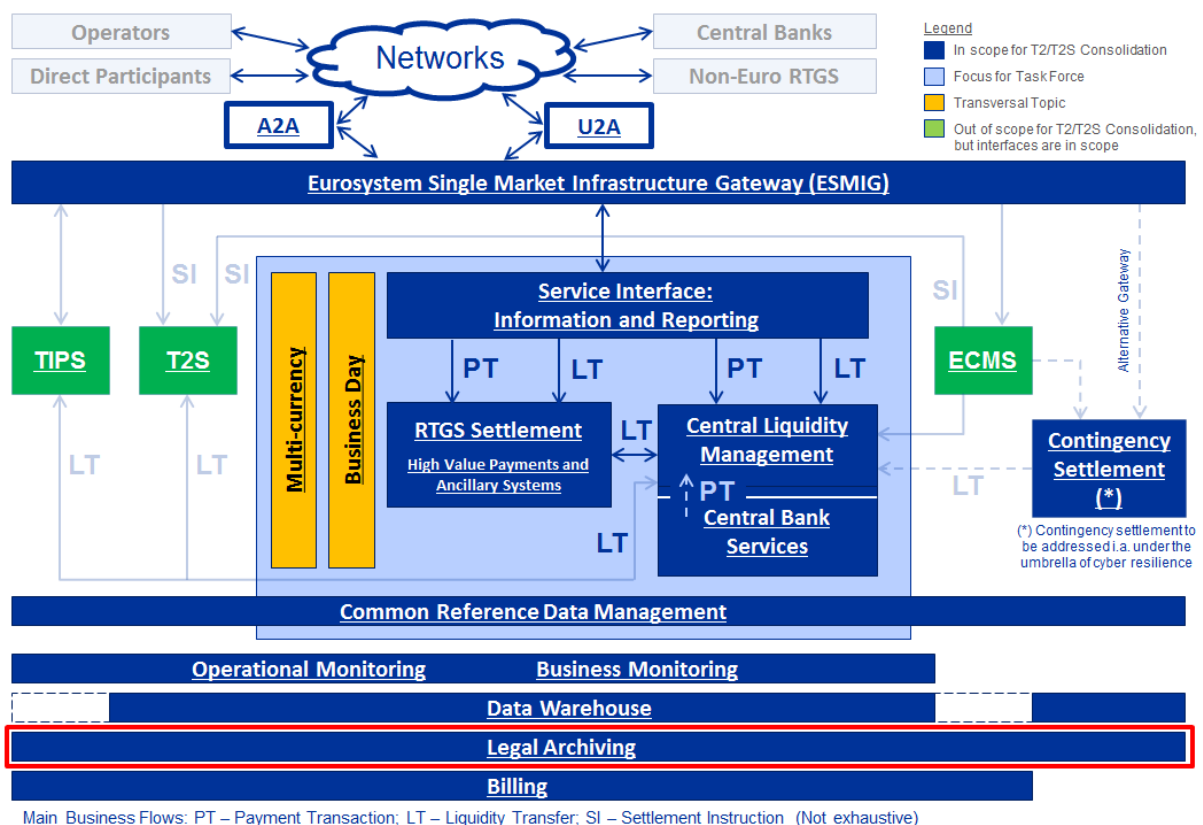

Figure 3: Context diagram for Legal Archiving

2.1.2 Business Processes

Business Process Name	BP Reference	Business Process Description
Collect Information for Legal Archiving	SHRD.CB.BP.LAR.COLL	Process to collect data within the various S services, <u>components and applications</u>
Gather Information	SHRD.CB.BP.LAR.GATH	Process to access collected information for legal requests

Table 4: Business Processes for Legal Archiving

2.2 COLLECT INFORMATION FOR LEGAL ARCHIVING

Business Process Ref: SHRD.CB.BP.LAR.COLL

This business process describes the archiving of legally relevant data for regulatory purposes. It encompasses the archiving for legal reasons of inbound and outbound messages and files processed in ~~the~~ Eurosystem Single Market Infrastructure Gateway (ESMIG). Archived messages will be retained for a pre-defined period of 10 years.

The process flow description is not intended to pre-determine any solution, e.g. that messages need to be sent to ~~the~~ Legal Archive on the one hand, or sending of messages to ~~the~~ Legal Archive might not be needed on the other hand. That will ultimately depend on the technology chosen.

2.2.1 Business Process Model

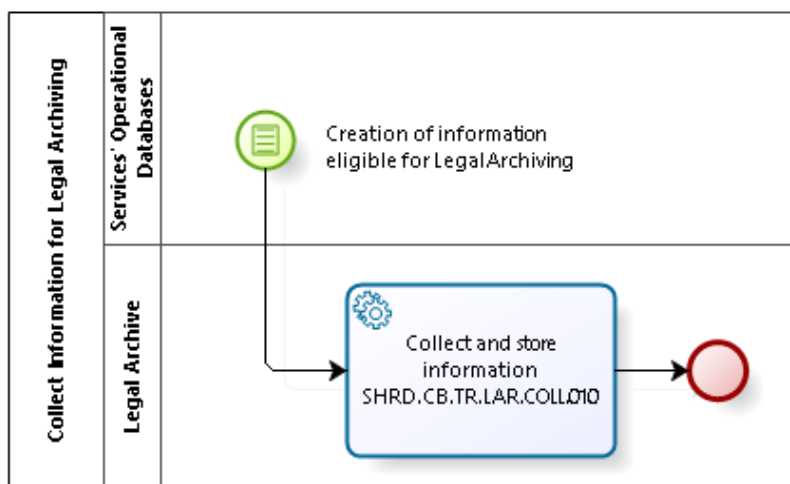

Business Process Model 11: Collect Information for Legal Archiving

2.2.2 Process Overview

Process goal:

The process describes collection and storage of business data relevant for legal archiving without influencing the smooth operations of the ~~S~~services, components and applications.

Process context:

- ▶ This process runs in the background to retrieve data from operational databases.

Pre-conditions:

- ▶ None

Time constraints:

- ▶ None

Expected results:

- ▶ Data relevant for legal archiving and being in a final state is stored in a way which makes it impossible to manipulate or delete it before the expiry of the retention period.

Triggers:

- ▶ Finalisation of data relevant for legal archiving.

2.2.3 User Requirements

2.2.3.1 COLLECT AND STORE INFORMATION

Task Ref: SHRD.CB.TR.LAR.COLL.010

The information identified to be archived will be collected and loaded into ~~the~~ Legal Archive.

Id	SHRD.CB.UR.LAR.COLL.010.010
Name	Legal Archiving - Collection
Description	Upon the finalisation of data entries which require legal archiving the S services, <u>components and applications</u> shall provide data for the legal archive.

Id	SHRD.CB.UR.LAR.COLL.010.020
Name	Legal Archiving Scope
Description	The data to be archived encompasses inbound and outbound messages of legal relevance, e.g. all payment orders. Messages between the S services, <u>components and applications</u> (e.g. a collateral settlement instruction from ECMS to T2S) do not need to be legally archived. Neither do queries, technical messages or logs for U2A activities. Legal Archive shall be able to handle a broader scope if necessary.

Id	SHRD.CB.UR.LAR.COLL.010.030
Name	Data Format
Description	The data in the Legal Archive shall be stored in its original format.

Id	SHRD.CB.UR.LAR.COLL.010.040
Name	Data Protection

Description	The data archived has to be protected and secured in its original format. Neither changes nor deletions shall be possible once information is legally archived.
--------------------	---

Id	SHRD.CB.UR.LAR.COLL.010.050
Name	Archive Retention period
Description	The data archived will be retained for specific retention periods. Legally relevant messages, e.g. all payment orders, are archived for at least 10 years.

In the detailed specification it might be possible to differentiate retention period of different data sources or local regulation rules. Nevertheless the means for storing data at least 10 years has to be in place.

2.3 GATHER INFORMATION

Business Process Ref: SHRD.CB.BP.LAR.GATH

This business process describes the access to legally archived information. Legal Archiving only describes the data gathering process. Other issues, for example, report generation, data preparation or available views, will be handled by the TARGET Service Desk, the user interacting by external channels such as mail.

2.3.1 Business Process Model

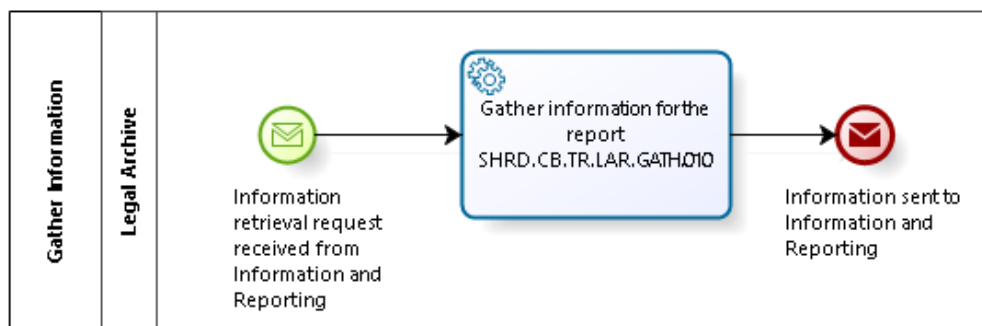

Business Process Model 12: Gather Information

2.3.2 Process Overview

Process goal:

This process describes the access to data stored in Legal Archive. Upon request the archived data will be returned.

Process context:

- ▶ Any access to data contained in Legal Archive is described by this process.

Pre-conditions:

- ▶ None

Time constraints:

- ▶ None

Expected results:

- ▶ The requested data shall be returned by the process.
- ▶ The data access shall not jeopardise the service level for operations.

Triggers:

- ▶ Information requests

2.3.3 User Requirements

2.3.3.1 GATHER INFORMATION FOR THE REPORT

Task Ref: SHRD.CB.TR.LAR.GATH.010

Id	SHRD.CB.UR.LAR.GATH.010.010
Name	Information Access
Description	Upon request, access to the collected information shall be available to the TARGET Service Desk.

It is currently foreseen that only operators have read access to data in Legal Archive.

Id	SHRD.CB.UR.LAR.GATH.010.020
Name	Information display
Description	The display of information will be managed by the TARGET Service Desk, and sent to the requester by external means.

2.4 NON-FUNCTIONAL REQUIREMENTS FOR LEGAL ARCHIVING

2.4.1 Availability

Id	SHRD.CB.UR.LAR.NFR.020
Name	Availability
Description	Availability, calculated on a quarterly basis, shall be at least 97.5%.

Legal Archiving may be subject to incidents or failures, which may cause a temporary and unforeseen interruption of availability of the componentService. Regardless of the total number of such unplanned interruptions, the overall availability calculated on a quarterly basis shall be at least 97.5%.

2.4.2 Disaster Recovery

Id	SHRD.CB.UR.LAR.NFR.030
Name	Recovery Point Objective
Description	Legal Archiving shall ensure a recovery point objective of zero minutes to recover to the complete set of archived data in the event of site failures or where there is a loss of a complete region.

The recovery point objective (RPO) is a point of consistency to which a user wants to recover or restart the Sservice.

Id	SHRD.CB.UR.LAR.NFR.040
Name	Recovery Time Objective
Description	Legal Archiving shall ensure a recovery time objective value of four days in the event of site failures or where there is a loss of a complete region

The recovery time objective (RTO) is the maximum amount of time required for recovery or restart of the Service to a specified point of consistency. In the event of a site failure, Legal Archiving shall ensure maximum time of unavailability of four days starting from the time when the decision to restart the componentService is made up to the time the componentService is restored. In the event of a major failure or a regional disaster, Legal Archiving shall ensure maximum time of unavailability of four days starting from the time when the decision to restart the componentService is made up to the time the componentService is restored.

2.4.3 Performance Requirements

Id	SHRD.UR.LAR.NFR.050
Name	Query Response Time
Description	Legal Archiving shall handle simple queries with in an elapsed time of one day for 95% of the interactions. For complex queries the response time shall be four days for 100% of the interactions. A possibility to abort long-running queries shall be given.

A basic query is a query to retrieve a single object. User interactions to retrieve complex data or large amounts of data shall be handled with the possibility of an extended response time.

3 CONTINGENCY Settlement Services (CONT)

3.1 OVERVIEW

3.1.1 Context Diagram

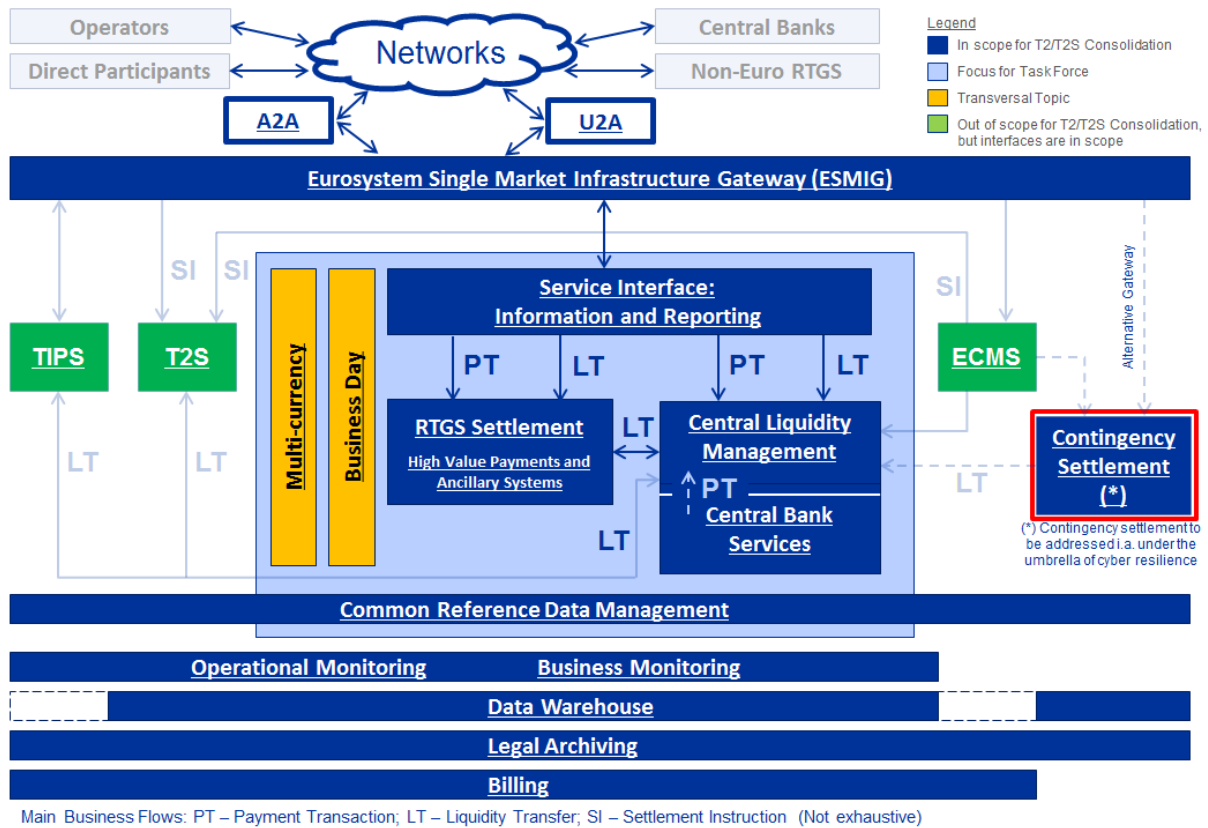

Figure 4: Context diagram for Contingency Settlement Services

3.1.2 General Description of Contingency cases

The Contingency Settlement Services serves both CLM and RTGS. As a general rule, the usage of the contingency settlement component module is envisaged only for major failure, regional disaster, or successful cyber-attack. However, where there is a limited number of unprocessed time-critical transactions in RTGS or CLM (e.g. monetary policy related transactions, continuous linked settlement (CLS) operations) at the time of the incident, then this can lead to the activation of the contingency settlement component module, whatever the cause of the unavailability. The Contingency Settlement Services shall have their own fully segregated ESMIG components.

The settlement of transactions in a contingency case shall be performed on specific accounts dedicated for contingency settlement, having a starting balance of zero. It shall be ensured that the contingency activities are traceable (e.g. through specific transaction reference numbers) and reconcilable with the production CLM and RTGS services—after recovery. The Contingency

SettlementServices shall be complementary to and independent from the production system, and itthey can run in parallel with the latter.

3.1.3 General Assumptions for Contingency SettlementServices

Assumption – Non-availability/non-accessibility of RTGS and/or CLM (including CBS)

It is assumed that RTGS and/or CLM (including CBS) are not available or not accessible to the participants. Additionally, it is assumed that the standard network connections between the Parties and participantsaccount holders involved and the Contingency SettlementServices are fully available.

The rationale behind this is that if the Eurosystem Market Infrastructure Services are fully accessible through the usual network connectivity means, then despite the general contingency case, the Contingency SettlementServices shall also be accessible through the standard connectivity means to Ancillary Systems, banks and other account holdersparticipants.

3.1.4 User Requirements for Connectivity to the Contingency SettlementServices

Id	SHRD.CB.UR.CONT.CONN.010
Name	Connectivity - Access to the Contingency <u>SettlementServices</u> through ESMIG
Description	The Contingency <u>SettlementServices</u> shall be accessible through an instance of ESMIG fully segregated from the production system.

Note: The rationale behind this is that, if the standard network connectivity is fully available despite the general contingency case, the Contingency SettlementServices shall be accessible through the standard connectivity means also to Ancillary Systems, banks and other account holdersparticipants.

3.1.5 User Requirements for Common Reference Data

Id	SHRD.CB.UR.CONT.CRDM.010
Name	Reference data - basis
Description	The Contingency <u>SettlementServices</u> shall, for those reference data items needed in the Contingency <u>SettlementServices</u> , use the latest reference data available from the Common Reference Data. .This shall, in any case, be no earlier than as at the End of Day of the previous business day.

Id	SHRD.CB.UR.CONT.CRDM.020
Name	Reference data – entities
Description	The Contingency <u>SettlementServices</u> shall use the following entities from

Common Reference Data:

- Party (including all Ancillary Systems and account holdersparticipants)
- Party Name
- Party Address
- Party Code
- Banking Group
- Cash Account (CLM MCA or RTGS DCA)
- Currency
- SWIFT BIC Directory
- Service
- User
- Distinguished Name
- Role
- Privilege
- Access Rights

Note: Central Banks shall ensure that, in the Common Reference Data, there is at least one contingency account for each of their account holderparticipant/Ancillary System having at least one RTGS DCA in RTGS or an MCA in CLM in production. The contingency account must also have the same currency. By this mean, a working set of accounts is already available in the Contingency SettlementServices before the contingency case.

Note: Central Banks must ensure that an account holderparticipant/Ancillary System can have accounts only to the extent laid down in the Guidelines. E.g. CLS can have an account as an Ancillary System, whereas other Ancillary Systems which have only technical accounts in RTGS must *not* have a contingency account.

Id	SHRD.CB.UR.CONT.CRDM.030
Name	Reference data - amendment of reference data
Description	The Contingency <u>SettlementServices</u> shall allow the TARGET Service Desk to amend reference data.

Note: The TARGET Service Desk shall be able to block/unblock accounts and account holdersparticipants/Ancillary Systems in ~~the~~ Contingency SettlementServices. Deletion does *not* need to be supported by the Contingency SettlementServices. After the contingency case, the Contingency SettlementServices does *not* need to reconcile the reference data with the Common Reference DataShared Services.

3.1.6 User Requirements for User Interactions with Contingency Services

Id	SHRD.CB.UR.CONT.UI.010
Name	Access to GUI (U2A)
Description	The Contingency <u>SettlementServices</u> shall allow for a U2A connection through a Graphical User Interface.

Id	SHRD.CB.UR.CONT.UI.020
Name	Status of the Contingency <u>SettlementServices</u>
Description	The Contingency <u>SettlementServices</u> shall be permanently closed by default. With this status, it is ensured that no one can access it by default. The opening as well as the closing (once the contingency case has ended) of the contingency <u>settlement componentmodule</u> is performed at a centralised level.

Id	SHRD.CB.UR.CONT.UI.030
Name	Control of participant's access
Description	The Contingency <u>SettlementServices</u> shall allow CBs to control the access of their <u>account holdersparticipants</u> and Ancillary Systems to the Contingency <u>SettlementServices</u> in U2A mode.

Note: Central Banks shall switch on/off the permission of their account holdersparticipants to access to ~~the~~ Contingency SettlementServices depending on the underlying root cause; e.g. if ESMIG is available, banks and other account holdersparticipants shall be allowed to access the Contingency SettlementServices through the standard connection, otherwise not.

Id	SHRD.CB.UR.CONT.UI.040
Name	Liquidity provision
Description	The Contingency <u>SettlementServices</u> shall allow CBs to transfer liquidity from their own accounts in the Contingency <u>SettlementServices</u> to the account of one of its participants in U2A mode through a GUI.

Id	SHRD.CB.UR.CONT.UI.050
Name	Monitoring of account balances

Description	The Contingency <u>SettlementServices</u> shall allow each <u>account holderparticipant</u> /Ancillary System to monitor its account balances in U2A mode through a GUI.
Id	SHRD.CB.UR.CONT.UI.060
Name	Liquidity Monitoring
Description	The Contingency <u>SettlementServices</u> shall provide a facility to CBs for the continuous monitoring of liquidity on all accounts of their <u>account holdersparticipants</u> /Ancillary Systems in U2A mode via screens.
Id	SHRD.CB.UR.CONT.UI.070
Name	Payment Order Processing - entry of payment <u>orders</u>
Description	<p>The Contingency <u>SettlementServices</u> shall allow <u>account holdersparticipants</u>/Ancillary Systems to set up single payment <u>orders</u> in U2A mode. The Contingency <u>SettlementServices</u> shall allow CBs to set up a payment <u>order</u> on behalf of its participants in U2A mode. The following attributes are required:</p> <ul style="list-style-type: none"> • Debited account • Credited account • Amount • Currency • Automatic reference (created by the Contingency <u>SettlementService</u>). <p>The following attributes are required optionally and are purely descriptive for tracking purposes:</p> <ul style="list-style-type: none"> • <u>R</u>reference given by the customer including the payment type (up within the first 4 characters, e.g. "CLS")
Id	SHRD.CB.UR.CONT.UI.080
Name	Upload of Ancillary System <u>transfertransaction</u> files
Description	The Contingency <u>SettlementServices</u> shall allow CBs to upload <u>transfertransaction</u> files for Ancillary Systems on their behalf in U2A mode and A2A mode. The Contingency <u>SettlementServices</u> shall ensure that the file contains a list of single <u>AS transferpayment</u> orders with the attributes given above <u>for payment orders</u> .

Note: Only Central Banks will have the possibility to upload files. Central Banks may upload files for Ancillary Systems on their behalf.

Id	SHRD.CB.UR.CONT.UI.090
Name	Monitoring of <u>ordertransactions</u>
Description	The Contingency <u>SettlementServices</u> shall allow each <u>account holderparticipant</u> /Ancillary System to monitor its <u>ordertransactions</u> in U2A. The Contingency <u>SettlementServices</u> shall allow each <u>account holderparticipant</u> /Ancillary System to commonly monitor all <u>ordertransactions</u> within one file in U2A mode.

Note: There is *no* specific requirement on automated notifications on a settlement success/failure of a payment order to the account holdersparticipants/Ancillary Systems. Information is only provided via GUI browsing.

Id	SHRD.CB.UR.CONT.UI.100
Name	Payment Order Processing - status information
Description	The Contingency <u>SettlementServices</u> shall provide a facility to CBs for the continuous monitoring of the payment order status of all their <u>account holdersparticipants</u> /Ancillary Systems via an U2A screen.

Id	SHRD.CB.UR.CONT.UI.110
Name	Reporting - statements of accounts
Description	The Contingency <u>SettlementServices</u> shall provide statements of accounts with an overview of the positions for the <u>account holdersparticipants</u> within each End of Day process.

Id	SHRD.CB.UR.CONT.UI.120
Name	Reporting – General Ledger Files
Description	The Contingency <u>SettlementServices</u> shall provide general ledger files to Central Banks within each End of Day process.

Note: ~~The~~ Contingency Settlement Services shall provide the financial data needed for the preparation of other Eurosystem daily publications, e.g. the daily aggregated Eurosystem financial data.

Id	SHRD.CB.UR.CONT.UI.130
Name	Central Banks - provision of raw data
Description	The Contingency <u>Settlement Services</u> shall make the raw data available to the CBs within each End of Day process.

Note: Central Banks can access the raw data through ~~the~~ Data Warehouse after recovery.

Id	SHRD.CB.UR.CONT.UI.140
Name	Billing - provision of raw data
Description	The Contingency <u>Settlement Services</u> shall provide raw data to Billing after recovery in A2A mode.

Id	SHRD.CB.UR.CONT.UI.150
Name	Data Warehouse/Legal Archiving - provision of raw data
Description	The Contingency <u>Settlement Services</u> shall provide raw data to the Data Warehouse/Legal Archiving after recovery in A2A mode.

3.1.7 User Requirements for Liquidity Management

Id	SHRD.CB.UR.CONT.LIQ.010
Name	Starting Balances
Description	When opening the Contingency <u>Settlement Services</u> the starting balance on all accounts shall be “zero”.

Id	SHRD.CB.UR.CONT.LIQ.020
Name	Separate liquidity provisioning
Description	The Contingency <u>Settlement Services</u> shall allow Central Banks to provide liquidity (debiting its own account and crediting the account of a participant) in

	U2A mode via GUI or in A2A mode based on collateral available in a Collateral Management System. The amount to be provided needs to be elaborated by the Central Bank outside of the Contingency <u>SettlementServices</u> .
--	---

Id	SHRD.CB.UR.CONT.LIQ.030
Name	End of Day Processing: Change of business date and continuation of balances
Description	The Contingency <u>SettlementServices</u> shall be able to change the business date (i.e. to remain active for more than one business day) and to carry over balances with the change of business day during the contingency case until its closure.

Note: ~~The~~ Contingency SettlementServices does not need to calculate the minimum reserves and excess liquidity as well as the respective interests *during* the contingency case, even if the contingency case lasts through the last day of the minimum reserve period. This shall be performed after recovery ~~–outside the~~ Contingency SettlementServices. Moreover a usage of ~~the~~ Standing Facilities is not foreseen.

Id	SHRD.CB.UR.CONT.LIQ.040
Name	Transfer of balances after closure of the contingency case
Description	The Contingency <u>SettlementServices</u> shall transfer the balances remaining on the contingency accounts after the closure of the contingency case to the linked CLM MCA or RTGS DCA, respectively, set up in the Common Reference Data. The Contingency <u>SettlementServices</u> shall provide all information needed to CLM in order to allow CLM to calculate the minimum reserves and excess liquidity as well as the respective interests after recovery. The Contingency <u>SettlementServices</u> shall transfer all information necessary for the alignment of the processed business day(s) for further processing by the concerning services (e. g. CLM, RTGS).

Note: ~~The~~ Contingency SettlementServices does not need to calculate the minimum reserves and excess liquidity as well as the respective interests after recovery.

3.1.8 User Requirements for Mechanisms of the Settlement Flow

Due to the systemic nature, very critical payment orders (e.g. CLS payments, EURO1 payments, STEP2 payments, margin calls with CCPs) have to be settled with highest priority, also considering that there is only limited amount of liquidity available in ~~the~~ Contingency SettlementServices. Since no technically enforced mechanism will be in place to prioritise such payment orderstransaction and given the fact that banks and Ancillary Systems have direct access to the contingency facility, Central Banks shall impose an ad-hoc prioritisation or “cherry picking” of very critical payment orderstransactions through operational means. This is to ensure that very critical payment orders are settled before other critical ones are processed.

~~The~~ Contingency SettlementServices does not support Ancillary System settlement procedures through technical mechanisms. Ancillary Systems and their Central Bank and settlement banks have to come to a common agreement on how to set up the AS transfer payment orders in the contingency case. For instance, an Ancillary System using Standard Multilateral Settlement would ask its Central Bank to upload a file with all the debits first. Once ~~the~~ Contingency SettlementServices hasve confirmed that all debits have been settled, the Ancillary System would ask its Central Bank to upload a file with all the credits. If one of the AS transfer orderspayments fails, the already settled AS transferstransactions in the files have to be reversed through a new file with reverse AS transfer orderspayments.

Id	SHRD.CB.UR.CONT.SETT.010
Name	Validation of payment orders/ <u>L</u> iquidity transfer orders
Description	The Contingency <u>SettlementServices</u> shall allow Central Banks to agree/disagree on the processing of each payment order/liquidity transfer order entered by the <u>account holdersparticipants</u> in U2A mode.

Id	SHRD.CB.UR.CONT.SETT.020
Name	Settlement of payment orders/liquidity transfer orders
Description	The Contingency <u>SettlementServices</u> shall attempt settlement of a payment order / liquidity transfer order immediately after it has been submitted for settlement by the Party and agreed by the Central Bank. If the first attempt failed, the Contingency <u>SettlementServices</u> shall reject the payment order <u>with the appropriate error message displayed on the screen</u> (no queuing mechanism is in place). The Contingency <u>SettlementServices</u> shall provide information on the status of the payment order (e.g. waiting for CB approval, settled, rejected) upon request.

Note: There is no requirement to queue payment orders not settled in the first attempt.

3.1.9 Non-functional Requirements

Id	SHRD.CB.UR.CONT.NFR.010
Name	Response Time Goals
Description	The Contingency <u>SettlementServices</u> shall be able to process 95% of the transactions under five minutes.

Id	SHRD.CB.UR.CONT.NFR.020
Name	Peak Workload per minute
Description	The Contingency <u>SettlementServices</u> shall be able to process 1,000 transactions per minute, enduring the peak load for at least 20 minutes.

Id	SHRD.CB.UR.CONT.NFR.025
Name	Peak Workload per day
Description	The Contingency <u>SettlementServices</u> shall be able to process in average 40,000 transactions per day, enduring the peak load 55,000 for at least 5 days.

Id	SHRD.CB.UR.CONT.NFR.030
Name	Service times
Description	The Contingency <u>SettlementServices</u> shall be available around the clock throughout the contingency case, apart from during necessary functional or technical maintenance windows.

Note: If ~~the~~ Contingency SettlementServices changes the business date, there must be an End of Day/Start of Day phase through which Contingency SettlementServices isare not available. Apart from that, there are no specific time windows for specific settlement mechanism during the contingency case, i.e. there is no specific night time settlement etc.

Id	SHRD.CB.UR.CONT.NFR.040
Name	Technical System sizing

Description	The Contingency Settlement Services shall be technically sized to allow processing and storage of up to five consecutive business days.
Id	SHRD.CB.UR.CONT.NFR.050
Name	Maximum Start Up Time
Description	The Contingency Settlement Services shall be up and running within at most two hours after detection of the contingency case.
Id	SHRD.CB.UR.CONT.NFR.060
Name	Hardware, Operation System and Software
Description	<p>The Contingency SettlementServices shall be run on a hardware infrastructure with a significantly different risk profile from the hardware infrastructure that the RTGS and CLM are running on.</p> <p>The Contingency SettlementServices shall run as software with a significantly different risk profile from the software the RTGS and CLM are running <u>on</u>as.</p>

4 USER INTERACTION

The objective of this section is to provide the user requirements related to user interactions covering the usage of U2A or A2A mode. A Graphical User Interface (GUI) shall be provided, offering functionality to access information in U2A mode.

These requirements do not imply any particular consideration with regard to design and the implementation of the actual screens.

4.1 GENERAL USER REQUIREMENTS FOR USER INTERACTION

The following general requirements shall apply to ~~the~~ RTGS, CLM and Common Components Shared Services.

4.1.1 Query

Id	SHRD.CB.UR.ALL.UI.010
Name	Query Audit Trail
Description	Each <u>componentService</u> shall provide the functionality to query through U2A and A2A interfaces the modified data at the attribute level, the user performing the change and the timestamp of the change. It shall be visible which attributes were changed, together with the new values. The query shall return relevant business attributes of the Audit Trail.

Id	SHRD.CB.UR.ALL.UI.020
Name	Query System time
Description	All <u>Services-components</u> shall provide the functionality to query system time to align the time of a connected application through an application-to-application interface (A2A). The query shall return the System time.

4.1.2 Action

Id	SHRD.CB.UR.ALL.UI.030
Name	Amend/ Revoke Task(s)
Description	All <u>Services-components</u> shall provide the functionality to amend/ revoke

	task(s) through the U2A interface.
--	------------------------------------

Id	SHRD.CB.UR.ALL.UI.040
Name	Act on behalf
Description	<p>All Services-components shall provide the functionality to act on behalf through U2A and A2A interfaces for:</p> <ul style="list-style-type: none"> • Central Banks, to act on behalf of any Party belonging to their banking community, and • The TARGET Service Desk, to act on behalf of any Party.

Id	SHRD.CB.UR.ALL.UI.050
Name	Access rights
Description	<p>All Services-components shall ensure that a user can only access functionality and data that is allowed by the access rights granted to the user through the Roles associated with the user.</p>

Id	SHRD.CB.UR.ALL.UI.060
Name	Four-eyes (confirm, revoke, amend)
Description	<p>All Services-components shall provide the functionality to use the four-eyes approval, allowing the authoriser to confirm, revoke or amend.</p>

4.2 USER INTERACTION FOR BILLING

4.2.1 Query

It shall be noted that not all possible queries in Billing are listed below due to that fact that the fee structure has not been agreed yet. All described queries in this section shall be provided in U2A and A2A mode unless otherwise stated.

Id	SHRD.CB.UR.BILL.UI.010
Name	Query Billing Information of participant per billing period
Description	<p>Billing shall provide the functionality to query the billing information of participant per billing period.</p> <p>The Central Bank user can query within his data scope, which is determined</p>

	<p>by the Party BICs. The user shall specify the following mandatory selection criteria.</p> <p><u>Mandatory selection criteria:</u></p> <ul style="list-style-type: none"> • Either Billable Party BIC or Party Name • Billing Period (YYYY-MM) <p>The query shall return all business attributes of the billing information of the participant per billing period, including its processing status.</p>
--	---

Id	SHRD.CB.UR.BILL.UI.020
Name	Query consumption for each S service, <u>application and component</u> per billing period
Description	<p>Billing shall provide the functionality to query consumption for each Sservice <u>and component</u> per billing period. The Central Bank user can query within his data scope, which is determined by the Party BICs.</p> <p>The user shall specify the following mandatory selection criteria. In addition the query shall allow the user to specify an optional selection criterion.</p> <p>The following eConsumption <u>for following</u> Sservices, <u>applications and components</u> can be queried:</p> <ul style="list-style-type: none"> • CLM • RTGS (HVP/AS) • TIPS • <u>T2S</u> • <u>ECMS</u> • Other componentsservices (CRDM, DHW) <p><u>Mandatory selection criteria:</u></p> <ul style="list-style-type: none"> • Either Billable Party BIC or Party Name • Billing Period (YYYY-MM) <p><u>Optional selection criterion:</u></p> <ul style="list-style-type: none"> • Service/<u>component</u> <p>The query shall return all business attributes of the consumption for each Sservice <u>and component</u> per billing period, including its processing status.</p>

Id	SHRD.CB.UR.BILL.UI.030
----	------------------------

Name	Query Ancillary System consumption per billing period
Description	<p>Billing shall provide the functionality to query Ancillary System consumption per billing period.</p> <p>The Central Bank user can query within his data scope, which is determined by the Party BICs. The user shall specify the following mandatory selection criteria.</p> <p><u>Mandatory selection criteria:</u></p> <ul style="list-style-type: none"> • Either Ancillary System Billable Party BIC or Party Name • Billing Period (YYYY-MM) <p>The query shall return all business attributes of Ancillary System consumption per billing period, including their processing status.</p>

Id	SHRD.CB.UR.BILL.UI.040
Name	Query fees for each <u>Service, component and application</u>
Description	<p>Billing shall provide the functionality to query fees for each <u>Service, component and application</u>.</p> <p>The user shall specify the following mandatory selection criteria.</p> <p><u>Mandatory selection criteria:</u></p> <ul style="list-style-type: none"> • Service/<u>component/application</u> • Billable Items <p>The query shall return all business attributes of fees for each <u>Service, component and application</u>.</p>

Id	SHRD.CB.UR.BILL.UI.050
Name	Query VAT
Description	<p>Billing shall provide the functionality to query the VAT information.</p> <p>The Central Bank user can query within his data scope, which is determined by the Party BICs. The user shall specify the following mandatory selection criteria.</p> <p><u>Mandatory selection criteria:</u></p> <ul style="list-style-type: none"> • Service/<u>component/application</u>

	<ul style="list-style-type: none"> • Billable Items <p>The query shall return all business attributes of VAT information.</p>
--	--

4.2.2 Action

Id	SHRD.CB.UR.BILL.UI.060
Name	Amend VAT
Description	Billing shall provide the functionality to amend the VAT through the U2A interface.

Id	SHRD.CB.UR.BILL.UI.070
Name	Amend Invoice
Description	Billing shall provide the functionality to amend an invoice through the U2A interface.

Id	SHRD.CB.UR.BILL.UI.080
Name	Regenerate Invoice
Description	Billing shall provide the functionality to regenerate invoice through the U2A interface.

Id	SHRD.CB.UR.BILL.UI.090
Name	Send Invoice
Description	Billing shall provide the functionality to send an invoice through the U2A the interface.

Id	SHRD.CB.UR.BILL.UI.100
Name	Cancel Invoice
Description	Billing shall provide the functionality to cancel an invoice through the U2A interface.

The table below represents a summary of the queries and actions in Billing for CBs.

<u>Query / Action</u>	<u>U2A</u>	<u>A2A</u>
<u>Query Billing Information of participant per billing period</u>	X	-
<u>Query consumption for each service, application and component per billing period</u>	X	X
<u>Query Ancillary System consumption per billing period</u>	X	X
<u>Query fees for each service, component and application</u>	X	X
<u>Query VAT</u>	X	X
<u>Amend VAT</u>	X	
<u>Amend/Regenerate/Send/Cancel Invoice</u>	X	

Table 5: Summary of queries and actions in U2A and A2A mode for Billing

4.3 USER INTERACTION FOR COMMON REFERENCE DATA MANAGEMENT

4.3.1 Query

Id	SHRD.CB.UR.CRDM.UI.010
Name	Query Banking Group
Description	CRDM shall provide the functionality to query Banking Group through the U2A interface. The query shall return all business attributes of Banking Group.

4.3.2 Action

Id	SHRD.CB.UR.CRDM.UI.020
Name	Create Account
Description	CRDM shall provide the functionality to create an account through the U2A interface.

Id	SHRD.CB.UR.CRDM.UI.030
Name	Amend Account
Description	CRDM shall provide the functionality to amend an account through the U2A interface.

Id	SHRD.CB.UR.CRDM.UI.035
Name	Close Account
Description	CRDM shall provide the functionality to close an account through the U2A interface.

Id	SHRD.CB.UR.CRDM.UI.040
Name	Delete Account
Description	CRDM shall provide the functionality to delete an account through the U2A interface.

Id	SHRD.CB.UR.CRDM.UI.050
Name	Create Banking Group
Description	CRDM shall provide the functionality to create a Banking Group through the U2A interface.

Id	SHRD.CB.UR.CRDM.UI.060
Name	Amend Banking Group
Description	CRDM shall provide the functionality to amend a Banking Group through the U2A interface.

Id	SHRD.CB.UR.CRDM.UI.070
Name	Delete Banking Group
Description	CRDM shall provide the functionality to delete a Banking Group through the U2A interface.

Id	SHRD.CB.UR.CRDM.UI.080
Name	Create Party
Description	CRDM shall provide the functionality to create a Party through the U2A interface. When creating the Party it shall be possible to set up links between MCA and

	DCAs for liquidity management and minimum reserve purposes.
--	---

Id	SHRD.CB.UR.CRDM.UI.090
Name	Amend Party
Description	CRDM shall provide the functionality to amend a Party through the U2A interface.

Id	SHRD.CB.UR.CRDM.UI.100
Name	Delete Party
Description	CRDM shall provide the functionality to delete a Party through the U2A interface.

Id	SHRD.CB.UR.CRDM.UI.110
Name	Block Party
Description	CRDM shall provide the functionality to block a Party in the case of insolvency (or a similar event) in order to exclude it from all services, components and applications through the U2A interface.

Id	SHRD.CB.UR.CRDM.UI.120
Name	Unblock Party
Description	CRDM shall provide the functionality, through the U2A interface, to unblock a Party where the reason for blocking is no longer applicable and the Party is entitled to participate in all services, components and applications .

Id	SHRD.CB.UR.CRDM.UI.130
Name	Create Direct Debit Mandate
Description	CRDM shall provide the functionality to create a direct debit mandate through the U2A interface. Note: Create the reference data for mandates to allow direct debits between accounts that are eligible for direct debits.

Id	SHRD.CB.UR.CRDM.UI.140
Name	Amend Direct Debit Mandate
Description	CRDM shall provide the functionality to amend a direct debit mandate through the U2A interface.

Id	SHRD.CB.UR.CRDM.UI.150
Name	Delete Direct Debit Mandate
Description	CRDM shall provide the functionality to delete a direct debit mandate through the U2A interface.

Id	SHRD.CB.UR.CRDM.UI.160
Name	Block Cash Account
Description	CRDM shall provide the functionality to block an account through the U2A interface. It shall be possible to block debits and/or credits.

Id	SHRD.CB.UR.CRDM.UI.170
Name	Unblock Cash Account
Description	CRDM shall provide the functionality to unblock an account through the U2A interface.

Id	SHRD.CB.UR.CRDM.UI.180
Name	Create reference data in the directory
Description	CRDM shall provide the functionality to create reference data in the directory through the U2A interface.

Id	SHRD.CB.UR.CRDM.UI.190
Name	Amend reference data in the directory
Description	CRDM shall provide the functionality to amend reference data in the directory through the U2A interface.

Id	SHRD.CB.UR.CRDM.UI.200
Name	Delete reference data in the directory
Description	CRDM shall provide the functionality to delete reference data in the directory through the U2A interface.

Id	SHRD.CB.UR.CRDM.UI.210
Name	Grant access rights to banks, Ancillary System
Description	CRDM shall provide the functionality to grant access rights through the U2A interface.

Id	SHRD.CB.UR.CRDM.UI.220
Name	Create Events
Description	<p>CRDM shall provide the functionality to create an event through the U2A interface.</p> <p>Note: the respective event will become valid from the next business day only (i.e. for D+1). While CBs can define only <u>domestic</u> events applicable to their banking community (e.g. cut-off for cash withdrawals), system <u>widse</u> events are under the responsibility of the operator.</p>

Id	SHRD.CB.UR.CRDM.UI.230
Name	<u>AmendModify_Domestic</u> Events
Description	<p>CRDM shall provide the functionality to amend an event through the U2A interface.</p> <p>Note: the respective modification will be applicable from the next business day only (i.e. for D+1). While CBs are responsible for domestic events like cut-off for cash withdrawals, the system <u>widse</u> events are under the responsibility of the operator.</p>

Id	SHRD.CB.UR.CRDM.UI.240
Name	Delete Events

Description	<p>CRDM shall provide the functionality to delete an event through the U2A interface.</p> <p>Note: the respective deletion will be applicable from the next business day only (i.e. for D+1). While CBs can delete their own domestic events; the system wide events are under the responsibility of the operator.</p>
-------------	--

Id	SHRD.CB.UR.CRDM.UI.250
Name	Amend <u>System</u> Events (Operator only)
Description	<p>CRDM shall provide the functionality to <u>amendmodify</u> an event through the U2A interface</p> <p>Note: System wide events can be defined timewise by the operator (for D+1)</p>

Id	SHRD.CB.UR.CRDM.UI.260
Name	Create Central Bank (Operator only)
Description	<p>CRDM shall provide the functionality to create Central Bank through the U2A interface.</p> <p>Note: This functionality is only available for <u>the</u> operator.</p>

Id	SHRD.CB.UR.CRDM.UI.270
Name	Create Liquidity Transfer Group
Description	CRDM shall provide the functionality to a CB to create a Liquidity Transfer Group for a participant through the U2A interface

Id	SHRD.CB.UR.CRDM.UI.280
Name	Amend Liquidity Transfer Group
Description	CRDM shall provide the functionality to a CB to amend a Liquidity Transfer Group for a participant through the U2A interface.

Id	SHRD.CB.UR.CRDM.UI.290
Name	Delete Liquidity Transfer Group

Description	CRDM shall provide the functionality to a CB to delete a Liquidity Transfer Group for a participant through the U2A interface.
-------------	--

The table below represents a summary of the queries and actions in CRDM for CBs.

Query / Action	U2A	A2A
Query Banking Group	x	
Create/Amend/Close/ Delete Account	x	
Create/Amend/ Delete Banking Group	x	
Create/Amend/ Delete Party	x	
Block / Unblock Party	x	
Create/Amend/ Delete Direct Debit Mandate	x	
Block / <u>U</u> nblock Cash Account	x	
Create/ Amend/ Delete reference data in the directory	x	
Grant <u>A</u> ccess rights to banks, Ancillary System	x	
Create / <u>A</u> mend <u>D</u> omestic <u>M</u> odify/ Delete Events	x	
Amend <u>S</u> ystem Events (Operator only)	x	
Create Central Bank (Operator only)	x	
Create/ Amend/ Delete Liquidity Transfer Group	x	

Table 6: Summary of queries and actions in U2A and A2A mode for Common Reference Data Management

4.4 USER INTERACTION FOR DATA WAREHOUSE (DWH)

Data Warehouse shall allow Central Banks to conduct analytical researches with the possibility to freely design ad-hoc reports choosing relevant information data, joining queries across different data sources (T2S, RTGS (HVP/AS), CLM and CRDM) and setting conditions and filters.

As well, a list of pre-defined reports will be made available in the field of intraday credit (credit line and intraday credit via repo transactions), participant activity, billing and oversight (subset of the currently available pre-defined reports). The information and the listed reports below are not exhaustive; they will be defined in detail during the realisation phase of the project.

Results can be displayed on a screen or exported to various file types.

In order not to disrupt data analysis after the migration from TARGET2 to the future RTGS and CLM services, access to historical data from TARGET2 and T2S shall be provided.

4.4.1 Query

Id	SHRD.CB.UR.DWH.UI.010
Name	Query Analytics
Description	Data Warehouse shall provide the functionality to query all available business relevant information for analytical research through the U2A interface. The Central Bank user can query within his data scope, which is determined by the

	<p>Party BICs.</p> <p>The user shall be able to:</p> <ul style="list-style-type: none"> • Define the data entities to be returned; • Join different data sources (e.g. CLM, RTGS,<u>etc....</u>), specifying the type of the join; • Set conditions for executing the queries (e.g. 'BIC=AAAA%'); • Apply filters and sorting; • Aggregate; • Use result sets of pre-run queries; • Apply statistical functions; and • Limit amount of results. <p>Data Warehouse shall at minimum include access to the following information:</p> <ul style="list-style-type: none"> • <u>All transaction-level information (including settled and unsettled transaction messages)</u> • <u>All balances</u> • <u>All changes of credit line</u> • <u>All limits, reservations and other potential information with regard to the liquidity management of the participants</u> • Participant data • Business event • Billing and invoices data
--	---

Id	SHRD.CB.UR.DWH.UI.011
Name	Summary of required data scope (<u>settlement S</u> services)
Description	<p>The Central Bank user can query within his data scope, which is determined by the Party BICs.</p> <p>Access to granular data for all <u>Servicescomponents</u> shall include:</p> <ul style="list-style-type: none"> • CLM and all transactions between CLM and other <u>settlement S</u>services; • Central Bank related operations / transactions (open market operations, Standing Facilities, Reserve Management, Billing etc.); • Transactions related to participant's liquidity management; • RTGS and Ancillary System transactions; • Transactions on T2S DCAs; • All reference and static data

Id	SHRD.CB.UR.DWH.UI.012
Name	Summary of required data scope (types of data):

Description	<p>The Central Bank user can query within his data scope, which is determined by the Party BICs.</p> <p>Data in DWH shall at minimum include access to:</p> <ul style="list-style-type: none"> • All (original) transaction messages (settled and unsettled); • All End of Day balances; • All changes of credit lines; • All limits, reservations and other potential information with regard to the liquidity management of the participants; • Participant data; and • Business events.
--------------------	--

Id	SHRD.CB.UR.DWH.UI.013
Name	Summary of required data scope (attributes)
Description	<p>The Central Bank user can query within his data scope, which is determined by the Party BICs.</p> <p>Transaction-level information shall be provided especially about:</p> <ul style="list-style-type: none"> • Type of ISO 20022 compliant message (e.g. "pacs.008" or "camt.050"); • OperationService -identifier (e.g. "SF" for transactions related to Standing Facilities); • Priority of the transaction; • Settlement status of the transaction (e.g. "FI" for finally settled or "R" for rejected payment orders); • Payment type code and name derived from the transaction (e.g. "LTTIPS" / "Liquidity transfer from CLM to TIPS"); • Information (BIC, Account number, Legal Entity Identifier, Distinguished Name etc.) on all Parties (debited / credited participants, intermediaries as well as instructing Party and beneficiary) involved in a transaction; • Amount of transaction; • Introduction date and time; and • Settlement date and time.

Id	SHRD.CB.UR.DWH.UI.014
Name	Predefined Queries / Reports
Description	<p>Data Warehouse shall provide a subset of predefined reports/queries for business cases that are relevant to all CBs:</p> <ul style="list-style-type: none"> • Transaction search; • Statement of Account ; • Statistical Framework Report displaying the volume and value for each month and each payment/settlement service (overall and per CB)

	<ul style="list-style-type: none"> • Note: The classification relevant for the statistical framework shall be reviewed and defined during the realisation phase of the project. • Participant Report(s) (displaying the number of Parties and accounts overall/per Settlement service/per CB for a given day); • Participation Type Report (displaying the number of direct/indirect/etc. Parties overall/per settlement sService/per CB for a given day); • Minimum Reserve Fulfilment Report (displaying for all MFIs of a CB the Minimum Reserve fulfilment for a given day); • Use of Standing Facilities (displaying for all MFIs of a CB the use of Overnight Deposit and Marginal Lending Facility); • Credit Line Report (displaying for all MFIs of a CB the maximum amount and usage of credit line for a given day); • Banking Group Report (displaying information with regard to the Parties and accounts belonging to the same Banking Group); and • Critical Participants Report (allowing to identify "critical participants" in the system or within a settlement sService). <p>The Central Bank user can query within his data scope, which is determined by the Party BICs.</p>
--	--

Id	SHRD.CB.UR.DWH.UI.015
Name	Create and save a query as an ad-hoc report
Description	<p>Data Warehouse shall allow the creation of an ad-hoc report from scratch or based on a pre-defined report.</p> <p>Data Warehouse shall provide the functionality to save the created ad-hoc report for later adaptation and usage.</p> <p>Ad-hoc reports can be saved either for personal use or for sharing among all Central Banks. The results returned by such reports shall respect the data scope of the Central Bank user performing the query, which is determined by the Party BICs.</p>

Id	SHRD.CB.UR.DWH.UI.016
Name	Eurosystem analysis
Description	Data Warehouse shall support granting access at an aggregated level to Eurosystem data for analytic purposes. However, for these purposes access to personal information (e.g. name and address of Parties) shall not be granted.

Id	SHRD.CB.UR.DWH.UI.017
Name	Statistical Framework Reports
Description	Data Warehouse shall provide the functionality to store statistical data and to produce statistical reports.

4.4.2 Display

Id	SHRD.CB.UR.DWH.UI.020
Name	GUI requirements for analytics
Description	Data Warehouse shall provide user-friendly interface to design the queries and view the results. The interface shall give a business-oriented view of the data, including access to aggregated data.

4.4.3 Action

Id	SHRD.CB.UR.DWH.UI.030
Name	Export result sets
Description	Data Warehouse shall have an export functionality allowing to transfer transferring the results of a query to a chosen export format (e.g. .csv, .pdf, .xlsx, .txt) through the U2A interface.

Id	SHRD.CB.UR.DWH.UI.040
Name	Scheduling
Description	It shall be possible to schedule the reception of reports / the result of ad-hoc reports defined by the users.

4.5 USER INTERACTIONS FOR BUSINESS MONITORING

Id	SHRD.CB.UR.BM.UI.010
Name	Business Monitoring
Description	Business Monitoring shall provide the functionality to monitor the status and behaviour of the system from a business perspective via U2A mode.

	The monitoring menu shall be available for National Service Desks (Level 2) only.
--	---

The functions of the Business Monitoring are listed in the table below.

Function	Description
System	Display the availability of the whole system
Liquidity	Display information regarding payment <u>orders</u> and liquidity on an aggregated level. ⁷ See “Query aggregated liquidity for all C cash a Accounts (<u>only for Crisis Managers</u>)” (CLM.CB.UR.CBS.UI.070, <u>see section 3.2.1 on Query in the Annex to the User Requirements Document for Central Liquidity Management Annex</u>)
Payments	Monitoring of the processing of all payment <u>orders</u> and messages . The information shall be provided on an aggregated level. ⁷ See “Query payment <u>orders</u> per status for the whole banking community” (CLM.CB.UR.CLM.UI.040, <u>see section 3.3.1 on Query -as- in the Annex to the User Requirements Document for Central Liquidity Management-Annex-URD</u>)
Ancillary Systems	Monitoring of the processing of Ancillary System payments <u>and transfer orders</u> and availability of Ancillary System
Standing Facilities	Monitoring of the usage of Standing Facilities related to SF participants. ⁷ See “Query <u>Standing Facilities</u> transaction of the respective banking community” (CLM.CB.UR.CBS.UI.010, <u>see section 3.2.1 on Query in the CLM-Annex to the User Requirements Document for Central Liquidity Management</u>)
Reserve Management	Monitoring of the fulfilment of minimum reserve requirements related to (national) RM participants. ⁷ See “Query m Minimum reserve <u>requirements per participant of banking community</u> ” (CLM.CB.UR.CBS.UI.020, <u>see section 3.2.1 on Query in the CLM-Annex to the User Requirements Document for Central Liquidity Management</u>)

Table 7: Business Monitoring functions

4.6 USER INTERACTIONS FOR OPERATIONAL MONITORING

Id	SHRD.CB.UR.OM.UI.010
Name	Operational Monitoring
Description	Operational Monitoring shall provide the functionality to monitor system and business activities via U2A mode. This functionality shall cover the monitoring needs of the TARGET Service Desk (Level 3).

5 BUSINESS DATA DEFINITIONS

5.1 ENTITIES AND ATTRIBUTES

Id	SHRD.CB.UR.BDD.010
Name	Billing Information
Description	<p>This entity shall denote any information required for billing of any Service, component or application provided by the Market Infrastructure Services.</p> <p><u>Mandatory attributes:</u></p> <ul style="list-style-type: none"> • Billing Identifier The unique technical identifier of Billing Information • Invoice Identifier The unique technical identifier of an Invoice • Chargeable Party The Party incurring charges for services provided; • Billing Period The period for which charges are billed; • Charge Type Fixed or per item; • Billable Item Identifies the item for which a charge is made; and • Billable Item Price Either a single price for the Billable Item or a tiered pricing structure based on a parameter such as the volume of transactions within the period or the value of the transactions / balances etc. <p><u>Optional attributes:</u> n/a</p>

Id	SHRD.CB.UR.BDD.020
Name	Invoicing Information
Description	<p>This entity shall denote any information required for invoicing of any Service, component or application provided by the Market Infrastructure Services.</p> <p><u>Mandatory attributes:</u></p> <ul style="list-style-type: none"> • Invoice Identifier The unique technical identifier of an Invoice • Debited Account The account from which payment is to be collected; • Billable Party The Party to whom the bill shall be sent; • Billing Address The address to which the bill shall be sent;

Optional attributes:
n/a

List of Business Process Models

Business Process Model 1: Aggregate Billing Data.....	11
Business Process Model 2: Generate Invoice Data	18
Business Process Model 3: Send Consumption File	23
Business Process Model 4: Correct Invoice Data Manually	26
Business Process Model 5: Regenerate Invoice Data.....	31
Business Process Model 6: Create Invoice	34
Business Process Model 7: Send Invoice.....	39
Business Process Model 8: Cancel Invoice.....	43
Business Process Model 9: Direct Debit.....	47
Business Process Model 10: Billing Gather Information.....	51
Business Process Model 11: Collect Information for Legal Archiving.....	59
Business Process Model 12: Gather Information.....	62

List of Figures

Figure 1: Context diagram for Billing.....	5
Figure 2: Functional overview of the Billing process.....	8
Figure 3: Context diagram for Legal Archiving.....	57
Figure 4: Context diagram for Contingency Settlement.....	65

List of Tables

Table 1: Business Processes for Billing.....	6
Table 2: Billing terms and definitions used	7
Table 3: T2S invoicing for the cash side	12
Table 4: Business Processes for Legal Archiving.....	58
Table 5: Summary of queries and actions in U2A and A2A mode for Billing.....	81
Table 6: Summary of queries and actions in U2A and A2A mode for Common Reference Data Management	87
Table 7: Business Monitoring functions	92